

**TOWN OF JAMESTOWN RHODE ISLAND
DEPARTMENT OF PUBLIC WORKS
WATER DEPARTMENT**

**WATER SUPPLY SYSTEM MANAGEMENT PLAN
5-YEAR UPDATE**

Prepared for:

Rhode Island Water Resources Board
Division of Statewide Planning
235 Promenade Street, Suite 230
Providence, RI 02908

Prepared by:



Pare Corporation
8 Blackstone Valley Place
Lincoln, RI 02865

ORIGINAL SUBMISSION - APRIL 2024

FINAL

04/09/2024 7:51:19 AM

TABLE OF CONTENTS

<u>SECTION</u>	<u>DESCRIPTION</u>	<u>PAGE</u>
	Executive Summary	ES-1
1.0	Goals Statement	1-1
1.1	General JWD Goals and Objectives	1-1
1.2	State Guide Plan Element 721 – Rhode Island Water 2030	1-1
1.3	RIWRB Strategic Plan	1-2
2.0	Water Supply System Description	2-1
2.1	Organization and Legal Structure	2-1
2.2	System Description	2-3
2.3	Supply Sources	2-3
	2.3.1 Surface Water Supply	2-3
	2.3.2 Groundwater Resources	2-4
2.4	Infrastructure Components	2-4
	2.4.1 Water Treatment	2-4
	2.4.2 Storage Facilities	2-5
	2.4.3 Pumping Station	2-7
	2.4.4 Transmission Mains	2-7
	2.4.5 Distribution System	2-7
2.5	Interconnections	2-8
2.6	Service Area	2-8
	2.6.1 Geographic Area	2-8
	2.6.2 Present and Historic Water Services	2-11
	2.6.3 Population Served	2-11
	2.6.4 Population Distribution and Future Land Use	2-11
2.7	Source and Distribution Metering	2-12
2.8	System Production Data	2-14
2.9	System Water Use	2-14
	2.9.1 System-Wide and Per Capita Water Use	2-14
	2.9.2 Water Use by Category	2-14
	2.9.3 Major Users	2-15
	2.9.4 Non-Account Water Use	2-15
2.10	Water System Deficiencies	2-16
3.0	Water Quality Protection Component	3-1
3.1	Source Water Assessment Plan	3-1
3.2	Potential Impacts of Sea Level Rise	3-1
4.0	Anticipated Future Demands	4-1
4.1	Population and Economic Development	4-1
4.2	Projected Future Demands Based on Census Data	4-1
4.3	Projected Future Demands Based on 2024 Buildout Analysis	4-3
4.4	Projected Future Demand Based on Bedroom Data Only	4-5
4.5	Category & Subcategory and Major Users Future Demand	4-5
4.6	Legal Obligations to Provide Water	4-5
4.7	Service Area Extension	4-5
	4.7.1 Urban Water District	4-5



TABLE OF CONTENTS continued...

<u>SECTION</u>	<u>DESCRIPTION</u>	<u>PAGE</u>
	4.7.2 Jamestown Shores Neighborhood	4-6
	4.7.3 Consolidate the Two Current Water Districts into One Water District	4-6
5.0	Available Water	5-1
5.1	General	5-1
5.2	Physical Characteristics of the Reservoirs	5-1
5.3	Safe Yield of Surface Waters	5-1
	5.3.1 FS&T Safe Yield Analysis, October 2000	5-1
	5.3.2 Previous Analyses	5-2
5.4	Limitations to Water Use	5-4
5.5	Available Water/Demand Comparisons	5-4
5.6	Alternative Supply	5-5
5.7	Supply Augmentation Study	5-5
	5.7.1 Water Supply Committee Report (1995)	5-5
	5.7.2 Water Treatment Feasibility Study – 1999	5-6
	5.7.3 Limnological Baseline Study	5-7
6.0	Supply Management	6-1
6.1	Water Quality Protection	6-1
7.0	Demand Management	7-1
7.1	General	7-1
7.2	Demand Management Strategy (2012)	7-1
	7.2.1 Goals	7-1
	7.2.2 Residential Average Annual Per-Capita Water Use	7-2
	7.2.3 Efficient Water Use	7-2
	7.2.4 Full Accounting of Non-Billed Water	7-3
	7.2.5 Leakage	7-3
	7.2.6 Metering and Billing	7-4
7.3	Residential Retrofit Program (RRP) Plan	7-4
7.4	Major Users Technical Assistance Program	7-4
8.0	System Management	8-1
8.1	Statement of Objectives	8-1
8.2	Meter Installation, Maintenance, and Replacement (MIMR) Plan	8-1
8.3	Leak Detection and Repair (LDR) Plan	8-2
8.4	Preventive Maintenance (PM) Plan	8-2
9.0	Emergency Management	9-1
9.1	Emergency Management Planning	9-1
9.2	Known and Potential Risks to Water Supply System	9-1
	9.2.1 Hurricane	9-1
	9.2.2 Drought or Seasonal Water Storage	9-2
	9.2.3 Earthquake	9-3
	9.2.4 Hazardous Material Spill	9-4



TABLE OF CONTENTS continued...

<u>SECTION</u>	<u>DESCRIPTION</u>	<u>PAGE</u>
	9.2.5 Civil Unrest	9-5
	9.2.6 Vandalism	9-5
	9.2.7 Other Extraordinary Emergencies	9-6
9.3	Problem Identification/Assessment	9-6
9.4	General Responses	9-6
9.5	Specific Response Actions	9-7
	9.5.1 Treatment Plant	9-7
	9.5.2 Pump Station	9-7
	9.5.3 Storage Tanks	9-8
9.6	Notification Procedures	9-9
9.7	Recovery and Reverse Triggers	9-9
9.8	Preventative Measures	9-10
	9.8.1 Training	9-10
	9.8.2 Mock Emergency Exercises	9-11
9.9	Emergency Sources	9-12
10.0	Drought Management	10-1
10.1	General	10-1
10.2	System Operation in Drought Conditions	10-1
10.3	Agreements with Other Water Systems	10-2
11.0	Plan Implementation	11-1
11.1	General	11-1
12.0	Financial Management	12-1
12.1	General	12-1
12.2	Current Financial Management Practices	12-1
12.3	Future Revenue Sources	12-1
12.4	Assessment of Rates	12-2
12.5	Billing	12-3
13.0	Coordination	13-1
13.1	Consistency with Jamestown Comprehensive Plan	13-1
	13.1.1 Land Use	13-1
	13.1.2 Population	13-2
	13.1.3 Natural and Cultural Resources	13-2
13.2	Coordination with Other Water Suppliers	13-3
13.3	Coordination with Wastewater Collection Systems	13-3
13.4	Coordination with Local Fire Departments	13-3



TABLE OF CONTENTS continued...

<u>TABLES</u>	<u>PAGE</u>
1 Current and Projected Water Consumption Rates – Includes Census Population Growth Only	ES-4
2 Current and Projected Average Day & Maximum Daily Demands On Census Population Growth Only	ES-5
3 Current and Projected Water Consumption Rates Includes Population Growth Based on Build-Out Analysis Data	ES-6
4 Current and Projected Average Day & Maximum Daily Demands Based on Build-Out Analysis Data	ES-6
5 Water Rates – Minimum In Advance Charges	ES-10
6 Current Excess Water Rates	ES-11
7 Excess Seasonal Water Rates	ES-11
2.1 Typical Annual Non-Account Water Use	2-15
4.1 Population Projections (2020-2040)	4-1
4.2 Current and Projected Water Consumption Rates – Includes Census Population Growth Only	4-2
4.3 Current and Projected Average Day & Maximum Daily Demands On Census Population Growth Only	4-3
4.4 Current and Projected Water Consumption Rates Includes Population Growth Based on Build-Out Analysis Data	4-4
4.5 Current and Projected Average Day & Maximum Daily Demands Based on Build-Out Analysis Data	4-5
5.1 Safe Yield	5-2
5.2 Safe Yield with Transfer Pumping	5-2
5.3 North Pond Safe Yield	5-3
5.4 South Pond Safe Yield	5-3
9.1 Potential System Impacts under Various Emergency Conditions	9-1
12.1 Jamestown Water Total Revenue & Expenses (2020-2022)	12-1
12.2 Water Rates - Minimum In Advance Charges	12-2
12.3 Current Excess Water Rates	12-2
12.4 Excess Seasonal Water Rates	12-3

<u>FIGURES</u>	<u>PAGE</u>
2.1 JWD Organization Chart	2-2
2.2 Treatment Plant Flow Process Diagram	2-6
2.3 JWD Existing Service Territory Map	2-10
2.4 Jamestown Land Uses	2-13
3.1 SWAP Mapped Land Use Changes	3-2
3.2 SWAP Mapped Contaminant Sites	3-3
4.1 Jamestown Proposed Water District Map	4-8
6.1 Jamestown Source Water Map	6-3
Exhibit 1 – Town of Jamestown Water System – System Map	Follows Page 13-3



TABLE OF CONTENTS continued...

APPENDIX

- A. Worksheets
- B. Legislation Establishing Jamestown Water Board
- C. North Kingstown-Jamestown Emergency Supply Agreement
- D. FS&T Safe Yield Report (October 2000)
- E. Wellhead Protection Plan for the Community of Jamestown
- F. 2021 Consumer Confidence Report
- G. Hurricane Preparedness Plan
- H. Audited Financial Statements
- I. Letter to Jamestown Town Planner
- J. 2024 Water District Build-Out Analysis



EXECUTIVE SUMMARY

This Water Supply System Management Plan (WSSMP) has been prepared as required under Rhode Island General Laws 46-15.3, as amended and titled “The Water Supply System Management Planning Act” (Act). The legislative authority to effectuate the goals and policies of this Act has been conferred to the Rhode Island Water Resources Board (RIWRB). To this end, the RIWRB has promulgated the Rules and Regulations for Water Supply System Management Planning (490 RICR-00-00-2) and the Water Use and Efficiency Rule for Major Public Water Suppliers (490 RICR-00-00-1).

The Jamestown Water District (JWD), as a water purveyor supplying over 50 million gallons (MG) of water a year, is responsible for updating its WSSMP every 5 years. This WSSMP update has been prepared to be consistent with the goals of the Rules as well as the strategies and goals articulated in the RIWRB’s 2012 Strategic Plan and the RIWRB’s Water Use and Efficiency Rule for Major Water Suppliers. It is also consistent with the goals of State Guide Plan Element No. 721 – RI Water 2030 and the goals stipulated in the Comprehensive Plan for the Town of Jamestown.

Background

The JWD was established by special act of the General Assembly of the State of Rhode Island in March 1969. The original system, privately developed and owned, dated back to 1890. This system was limited to the village area of Jamestown and did not service the entire Town. The source of supply was derived from two surface water storage impoundments, the North and South Ponds, constructed in 1901 and 1909, respectively. North Pond was expanded to increase overall capacity in the early 1900s. The JWD, to this day, continues to derive its primary source of supply from North Pond.

A conventional water treatment plant was originally installed in 1920 and upgraded periodically over time. By the 1950s, the system served approximately 2,000 year-round residents and up to 4,000 seasonal residents. A distribution system and storage tank was in place to serve the southern portion of the island south of Rhode Island Route 138. In 1991, the Town constructed a new pretreatment facility and main treatment plant. The Town has since constructed a new treatment plant to replace the prior facility, which was put into service in 2010.

The service area for the public water supply is the Village area of Jamestown. This area consists of commercial and more densely developed residential properties within Jamestown. Water distribution piping was developed and extended to Fort Wetherill, Fort Getty, and Beavertail located south of the urban district when there was a military presence in Jamestown. This area is referenced as the rural district and over time residential properties were permitted to connect in this district. Water service connections in the rural water district area are subject to the approval of the Town’s Board of Water and Sewer Commissioners and must be consistent with the Comprehensive Community Plan.

Water System Description

The JWD supply and distribution system is classified by the Rhode Island Department of Health as a “Community” Public Water Supply System. As such, the system is required to conform to applicable rules and regulations of the Rhode Island Department of Health (RIDOH) and the Federal Safe Drinking Water Act (SDWA). The water system currently maintains full compliance with the stipulations of these rules and regulations.



The existing JWD system was developed primarily from the original water supply system that originated in the 1890's. Improvements to the infrastructure have been implemented over the years to maintain and upgrade the system to keep pace with increasingly stringent water quality regulations. The water quality has consistently been rated as good to excellent with occasional exceedances of secondary water quality standards for color and turbidity from the surface water supply of the reservoirs.

The water supply consists of two reservoirs that capture surface water runoff and two supply wells. The North Pond reservoir has a watershed of approximately 192 acres and a water body of 25.4 acres with a net usable water volume of 60 million gallons (70 million gallons total storage). The South Pond reservoir has a watershed of approximately 449 acres and a water body of 4.67 acres with a net useable volume of 8 million gallons (10 million gallons total storage). The two reservoirs are interconnected and deliver water to the treatment facility through a 10-inch PVC main. The total maximum safe day yield for North Pond is 194,000 gallons per day (gpd) and it is 89,000 gpd for South Pond. Two supply wells, JR-1 (installed 1996) and JR-3 (installed 2004), are each rated for 50,000 gpd though only one can be used at a given time. The JWD also maintains a non-permanent emergency interconnection (6-inch flexible water line) with the Town of North Kingstown water system across the Jamestown Verrazano Bridge. The interconnection has the capability of supplying the JWD with up to 200,000 gallons daily but is only used for emergencies. It has not been used since 2002.

The system employs a pretreatment facility located at South Pond. This facility pretreats between 180,000 to 350,000 gpd. Pretreatment consists of pH adjustment, chlorine dioxide (ClO₂) bleaching for odor, color, and taste, and flow monitoring. The main water treatment plant is a new facility that was constructed in 2010, replacing a facility that had been in service since 1991. The new facility was designed to treat up to 500,000 gpd, including raw water from South Pond. It also produces higher-quality finished water and reduces backwash water discharges to Great Creek.

Raw water enters into the clearwell of the 1991 treatment plant before passing through a screener and then into a chemical mixing tank where it undergoes pH adjustment and coagulant addition. Flow then splits into parallel treatment trains consisting of coagulation basins and membrane filtration basins. Finished water is pumped to the system's two storage tanks by a pump station with two 350 gpm pumps.

The transmission and distribution system consists of upwards of 20.5 miles of asbestos cement, cast iron, and polyvinyl chloride (PVC) pipeline, the majority of PVC piping is less than 20 years in age and ranges in size from 6 inches to 12 inches. New and replacement main sections consist predominantly of PVC pipe. The service area is operated as a single pressure zone that is controlled by the overflow elevation (204.0 feet MSL) of two (2) one-million-gallon storage standpipes. The original standpipe was constructed in 1974 and a second standpipe was constructed in 2007. These tanks establish the hydraulic grade and maintain system pressure in the range of 30 to 60 psi. The tanks are located alongside one another, and the useable storage capacity of each tank is estimated at 0.7 million gallons but there is a transfer pump station between the two tanks which effectively increases the usable storage of the two-tank system.

The source and distribution system is 100% metered. The water department staff is responsible for the daily operation and maintenance of the water system that also includes metering and billing of customers. The JWD is operated as an "Enterprise Fund Agency" within the municipal corporation of the Town of Jamestown. The Town has established enterprise funds for operations that are organized to be self-supporting through user charges. It is the intent that all costs of providing the



services to the general public on a continuing basis be financed or recovered fully through user charges.

The service population is comprised of residential, commercial, and government customers of which there are approximately 1,548 metered accounts as of 2022. Of the 1,548 metered accounts, there are 1,420 residential accounts, 96 commercial accounts, and 32 governmental accounts. The residential service population is approximately 3,323 of the roughly 5,538 residents in Town. The residential service population was estimated using recent US Census Data that suggests there are approximately 2.34 people per household throughout Jamestown. The remaining residents not serviced by the public water system are served via private individual wells. Current average day demand (ADD), based on measured water withdrawals from the JWD's supply sources in 2022, is approximately 168,000 gallons per day. Total water withdrawals were 61.17 million gallons in 2022, primarily from North Pond with supplemental withdrawals from well JR-1. On this basis, the maximum day demand (MDD) is estimated to be 335,000 gallons per day using an assumed MDD to ADD multiplier of 2.0.

Actual metered water use in the system was estimated to be 53.90 million gallons in 2022, representing an ADD of 0.148 MGD. The vast majority of total water use, approximately 47.81 million gallons or 89%, was residential water use. Per capita residential water use for 2022 was estimated at approximately 39.4 gallons per capita per day (gpcd) on average, which is less than the last WSSMP 5-year update (41.3 gpcd).

Given the limitations of supply and capacity of the existing system there is no ability to service the entire Town with water. The existing water system is limited in scope geographically to the village area within Jamestown and is not capable of extending beyond the water service area.

Water Quality Protection Component

Water quality protection is an important aspect to the JWD as the source of supply continues to be affected by growth, potential pollution sources, and increases in demand. The Source Water Assessment Plan (SWAP) for Jamestown was reviewed and updated as part of this WSSMP Update and has been included as Volume II of the WSSMP.

The Town currently employs zoning ordinances, site plan reviews, and has made numerous land purchases within the watershed and wellhead protection area. It has also created conservation easements for parcels within the wellhead protection area and an overlay district has been established for the Center Island Watershed. The Town also instituted a wastewater management ordinance which specifically addresses onsite wastewater treatment systems (OWTS) in the Jamestown Shores area. The intent of this ordinance is to increase inspection and maintenance requirements on existing OWTS to help protect water resources in order to reduce potential future pressures to extend water service to this area of Town. The Town does not believe the extension of water service to Jamestown Shores is feasible based on the current available supply.

Anticipated Future Demands

JWD projected the anticipated future demand of the water system through service area population data as a result of a build-out analysis based on recent and projected land use data. Tables 3 and 4 outline the results. JWD also compared the current bedroom data to provide the most conservative worst-case scenario with the existing town dwellings in place. The population in Jamestown is expected to rise gradually but modestly over time, and it is anticipated that the population changes in the JWD service area will generally mirror population changes throughout the Town. Also, future estimates of population for 5-year and 20-year planning periods were made using available US



Census data and projections made by the RI Division of Planning and outlined in Tables 1 and 2. These population projections, as well as their anticipated impacts on future demand, are summarized in the following tables.

**Table 1
CURRENT AND PROJECTED WATER CONSUMPTION RATES –
INCLUDES CENSUS POPULATION GROWTH ONLY**

Year	Total Population in Jamestown	Population Projected in Service Area	Metered/Projected Water Usage			Total	Average Day Demand*
			Residential	Commercial**	Government		
2022	5,538	3,323	47.81 MG	4.21 MG	1.87 MG	53.89 MG	0.148 MGD
2027	5,597	3,382	48.66 MG	5.05 MG	1.87 MG	55.58 MG	0.152 MGD
2042	5,679	3,464	49.84 MG	7.58 MG	1.87 MG	59.29 MG	0.162 MGD

* Based on consumption alone (i.e. non-account water not included)

** Commercial projections based on 2024 Build-Out Analysis Data

Residential water use for the 5-year period was projected based on a service area population of 3,382 people and an average per capita residential water use of 39.4 gpcd equivalent to the average per capita residential water use for 2022. Only modest population growth is expected over this timeframe and residential water use is anticipated to remain relatively consistent. Similarly, residential water use for the 20-year planning period was projected based on a service area population of 3,464 and 39.4 gpcd. This assumes that efficient residential water use continues to be a priority in Jamestown.

Water use by the government sectors in Jamestown has declined over time, and relatively little governmental development is expected in the JWD service area or in Jamestown as a whole. Governmental water usage for the 5-year and 20-year planning periods were projected to be equivalent to the fiscal year 2022 governmental usage of 1.87 MG. As part of the 2024 build-out analysis, the current commercial vacant land use for new development is almost at capacity and not much commercial growth is expected from vacant land use. There is potential commercial growth for existing commercial non-vacant lots that could be sub-divided into new lots that would increase system demand overtime. The commercial zone growth from non-vacant commercial lots is expected to be for residential usage with two (2) condos per lot. However, this growth would not be expected to occur all at once. As a result, commercial water usage for the 5-year and 20-year planning periods were projected to increase by five (5) new commercial connections each year. In 2042, the potential commercial growth would be close to capacity based on the development of non-vacant lots. Commercial non-vacant lot build-out development would be at capacity in 2053 if five (5) new commercial connection is established each year from 2022.

The JWD has traditionally used a maximum day to average day peaking factor of 2.0 to estimate maximum day demand (MDD) in the system. Table 2 shows the current ADD and MDD as well as projections for the 5-year and 20-year planning periods, based on consumption.



Table 2
CURRENT AND PROJECTED AVERAGE DAY & MAXIMUM DAILY DEMANDS ON
CENSUS POPULATION GROWTH ONLY

YEAR	AVERAGE DAY DEMAND*	MAXIMUM DAY DEMAND**
2022	0.148 MGD	0.296 MGD
2027	0.152 MGD	0.304 MGD
2042	0.162 MGD	0.324 MGD

* Based on consumption alone (i.e., non-account water excluded)

** Estimated using MDD to ADD ratio of 2.0

Projected estimates for water produced have been made assuming 11.88% non-account water, consistent with State goals. Therefore, the ADD and MDD based on water production are estimated to be 0.168 MGD and 0.336 MGD, respectively. For the 5-year planning period, the ADD and MDD are estimated to be 0.171 MGD and 0.342 MGD, respectively. Similarly, the ADD and MDD are estimated to be 0.175 MGD and 0.350 MGD for the 20-year planning period. It is noted that non-account water currently is below 15% (11.88%) but it has met the State’s goal of 15% in the past. This is mostly attributed to the process water requirements for the operation of the water treatment plants.

In January 2023, Rhode Island General Law 45-24, as amended and titled, “An Act Relating to Towns and Cities – Zoning Ordinances”, allows the owner to build an accessory dwelling unit (ADU) on any lot with a total area of 20,000 square feet or more for which the primary use is residential and where the proposed ADU is located within the existing footprint of the primary structure or existing secondary attached or detached structure and does not expand the footprint of the structure. The legislation was passed to address the projected shortage of housing by making it easier to build ADUs.

In 2024, the Town of Jamestown conducted an updated build-out analysis to reflect the current residential and commercial land use within the Town to forecast the potential new dwelling units and its impact on the existing water system. The potential new dwelling units were calculated using the current residential and commercial minimum lot zoning requirements on the developable vacant and non-vacant lots, and ADUs on residential vacant and non-vacant properties with lot sizes equal to or greater than 20,000 square-feet.

Table 3 contains the 5-year (2027) and 20-year (2042) future water use projections in the JWD water system estimating the residential and commercial population growth from potential current developable vacant and non-vacant lots, and ADUs. For this analysis, the governmental water usage remained the same as in Table 1 since it’s not anticipated that there will be much growth in these areas in the coming years. The commercial water projections as explained above and noted in Table 1 will be used in Table 3.

ADUs in Table 3 are estimated based on 12 new dwelling units constructed each year with half of the dwelling units being one-bedroom and the other half of the dwelling units being two-bedroom. Each year estimates that the Jamestown population will grow by 36 people (two people per bedroom) with the construction of ADUs alone. Table 3 also estimates that each year 4.0 vacant lots and 5.5 sub-dividable lots are used for new home construction with includes condominiums. Each year estimates that the Jamestown population will grow by 22 people (2.34 persons per



household) with the development of vacant and non-vacant developable sub-dividable properties. In total, each year there is an estimated population growth of 58 people in Jamestown.

**Table 3
CURRENT AND PROJECTED WATER CONSUMPTION RATES
INCLUDES POPULATION GROWTH BASED ON BUILD-OUT ANALYSIS DATA****

Year	Total Population in Jamestown***	Population Projected in Service Area With 2024 Build-Out Analysis	Metered/Projected Water Usage				Average Day Demand*
			Residential	Commercial	Government	Total	
2022	5,538	3,323	47.81 MG	4.21 MG	1.87 MG	53.89 MG	0.148 MGD
2027	6,023	3,614	51.99 MG	5.05 MG	1.87 MG	58.91 MG	0.161 MGD
2042	7,479	4,488	64.57 MG	7.58 MG	1.87 MG	74.02 MG	0.203 MGD

* Based on consumption alone (i.e., non-account water not included) with residential population increase from 2024 Build-Out Analysis)

** Based on residential and commercial projections from 2024 Build-Out Analysis Data

*** Assumed growth at the same rate as the water district

**Table 4
CURRENT AND PROJECTED AVERAGE DAY & MAXIMUM DAILY DEMANDS
BASED ON
BUILD-OUT ANALYSIS DATA**

YEAR	AVERAGE DAY DEMAND*	MAXIMUM DAY DEMAND**
2022	0.148 MGD	0.296 MGD
2027	0.161 MGD	0.322 MGD
2042	0.203 MGD	0.406 MGD

* Based on consumption alone (i.e., non-account water excluded)

** Estimated using MDD to ADD ratio of 2.0

Projected Future Demand Based on Bedroom Data Only

JWD also compared the current bedroom count in the water district to get a sense of what the future water demand would be if every bedroom currently in the water district was occupied. Currently, there are 4,271 total bedrooms in the water district and with two people per bedroom at 39.4 gpcd (estimated above), the future water demand could be as high as 337,000 gpd. This value represents the MDD that is currently experienced within the system at times and provides the most conservative worst-case scenario. The MDD is reached normally at the height of the summer season when there are a lot of seasonal visitors to the Town.



Available Water

The primary supply for the JWD is surface water from North Pond, supplemented with water from South Pond. Supplemental water from South Pond can be transferred to North Pond but only when water is flowing over the dam at South Pond. The capacity and safe yield of North and South Ponds, based on the most recent safe yield analysis performed in 2000, is as follows:

<u>Reservoir</u>	<u>Area</u>	<u>Usable Capacity</u>	<u>Safe Yield</u>
North Pond	25.4 Acres	60 MG	194,000 gallons/day*
South Pond	4.67 Acres	8 MG	89,000 gallons/day

South Pond has not been used for a number of years due to water quality concerns. The new treatment plant was designed with the ability to treat water from South Pond but the treatment process is inefficient due to the amount of sludge generated. *Currently, JWD is using the safe yield for North Pond of 185,000 gpd as a result of the RIDEM analysis and Drought of Record. South Pond is not available during dry periods and is only used to transfer water to North Pond when water is flowing over the South Pond dam.

The JWD also has two supply wells, JR-1 and JR-3, which each has a 50-gpm pumping capacity and safe yield of 50,000 gallons per day. Only one well is used at a given time, typically JR-1. Water from JR-1 is pumped only when the water treatment plant is in operation. As a result and based on plant data, flow from JR-1 varies between the range of 24,000 and 48,000 gallons per day. Flow from JR-1 varies throughout the year between this range and is at maximum pumping capacity during summer months. Currently, supply well JR-3 is not being used due to water quality concerns.

The current and projected future MDD, as well as the ADD during the peak summer season, exceed the safe yield of North Pond and often exceeds the combined safe yield of North Pond and JR-1. The JWD has taken a number of actions to manage demand, which is reflected by the decreases in water use when compared to previous versions of this WSSMP. However, it is imperative that the JWD continue to promote efficient water use, monitor land use and development within the service area, reduce leakage, improve their understanding and accounting of non-account water, and implement other demand management strategies to reduce pressures on the supply sources currently available to the JWD.

Demand Management

The *Rules and Procedures Governing the Water Use and Efficiency Act for Major Public Water Suppliers*, adopted May 16, 2011, established efficient water use targets for major public water suppliers, which includes the JWD. The JWD's 2012 Demand Management Strategy, and this update of the WSSMP, showed that the JWD is in general compliance with the residential average per capita water use goal of 65 gpcd, which was most recently estimated at 39.4 gpcd for 2022.

The JWD estimates non-billed water from various uses, such as firefighting, system flushing, and use at the treatment plant meets the metering and billing requirements stipulated in the Act, which includes quarterly billing for the entire system and the use of radio-read meters. The JWD encourages the use of water-efficient appliances and provides educational materials to the customer base.

The 2012 Demand Management Strategy estimated average leakage in the distribution system to be approximately 8.6% of system-wide water use, meeting the State's goal of 10%. However,



recent estimates of leakage as reported in this WSSMP are lower, estimated at about 1.6% for 2022 based on 1.0 MG of estimated leakage. This change in estimated leakage suggests that there may be other sources of non-account water that are not being adequately accounted for and estimated. The JWD will continue to assess leakage rates and will review their accounting of non-billed water as a whole.

System Management

The major goals of system management include the following:

- Maintaining non-account water use to below 15% of total system demand, in accordance with State Guide Plan Element 721;
- Reducing leakage to below 10% of system demand;
- Establishing a preventive maintenance program; and
- Maintaining compliance with the applicable requirements of the *Rules and Procedures Governing the Water Use and Efficiency Act for Major Public Water Suppliers*.

The JWD shall continue to employ proper system management procedures including programs for meter management (source and distribution), leak detection and repair, implementation of their preventive maintenance plan, infrastructure rehabilitation, and a billing rate schedule which promotes efficient and non-wasteful water use. It is intended that the financial management of the system will be one in which normal operation, maintenance, and rehabilitation will be funded through operating revenue from the customer base. Where possible, the JWD shall seek alternate funding sources such as State and Federal grants, for major improvement projects.

Emergency Management

The Emergency Response Section of this WSSMP was reviewed and modified accordingly as part of this WSSMP Update. The Emergency Response section generally establishes the following:

- Responsibilities and authority within the JWD for responding to most probable emergencies;
- Most probable causes for emergencies and their potential impacts to the system;
- System components that are vulnerable to damage or incapacitation based on the most likely causes for emergency; and
- Specific tasks for carrying out functional and constructive solutions based on a review of the potential emergencies and the associated system risks.

The procedures outlined are believed to be consistent with the goals of the State Emergency Water Supply System Management Plan. In addition to emergency response, it is also intended that this section of the WSSMP provide guidance to ensure that the primary aspects of recovery from an emergency are addressed in an organized manner to aid in an efficient response and in maintaining drinking water quality and quantity.

Drought Management

The JWD recognizes the Drought Watch/Warning System of the National Weather Service, as follows:

1. Normal;
2. Advisory;
3. Watch;



-
- 4. Warning; and
 - 5. Emergency

The Water Resources Board administers these phases with aid from the Drought Steering Committee. The JWD takes a variety of demand and supply management actions based on the various stages of drought. The JWD also monitors the water levels in their own supply sources and takes a series of actions in the distribution system based on these measurements, as follows:

- Step 1 Capacity to -6" below capacity
No restrictions
- Step 2 -6" to -1' below capacity
Public notification – voluntary conservation.
- Step 3 -1' to -2' below capacity
Restrict outside water use to odd/even days for residential use.
- Step 4 -2' to -3' below capacity
Reduce water pressure 5 psi.
Continue public notification for voluntary conservation.
- Step 5 -3' to -3.5' below capacity
Reduce pressure 5 psi.
Establish a residential ban on car washing and lawn watering.
Restrict swimming pool filling.
- Step 6 -3.5' to -5' below capacity
Ban outside water use entirely.
- Step 7 -5' to -6' below capacity
Reduce pressure 5 psi.
Restrict water use at marinas to potable water use only.
Begin commercial carwash and other non-essential commercial use restrictions.
- Step 8 -6' to -7' below capacity
Restrict all non-essential water use.
- Step 9 -7' to -8' below capacity
Reduce pressure 5 psi.
Continue restrictions on all non-essential water use.

There is no formal procedure for restricting water use beyond Step 9. In 1993, the drought reached Step 7. Water conservation resulted in a reduction in use of 20%. If a situation arises which requires further restriction of water use, all commercial and industrial users will be restricted.

As an additional effort to conserve water, JWD has the following rules to control use:

1. No customer shall connect an in-ground or underground irrigation or sprinkler system to the municipal water system. Lawn irrigation shall be prohibited from June 1 to August 31.
2. No customer shall use water furnished by the municipal water system for lawn irrigation, house washing, boat washing, or residential car washing when the height of North Pond is more than



42 inches below the top of the spillway and after publication of said information in a daily or weekly newspaper of general circulation within the Town of Jamestown.

- When the height of North Pond is from 42 inches to 60 inches below the top of spillway and after publication as noted above, no customer shall use water furnished by the municipal water system for any outdoor use.

Implementation and Financial Management

The JWD has undertaken two projects in an effort to increase supply, which is the most significant challenge facing the JWD system. One of these projects was a pumping system that recirculates treatment plant backwash water as opposed to dumping it to Great Creek. It is anticipated to be completed soon and is estimated to save the JWD approximately 6.05 million gallons annually once completed. A second project, which is currently in the preliminary evaluation stage, would include modifications to a stormwater pump station operated by the Rhode Island Bridge and Turnpike Authority (RIBTA) on North Road and Route 138 that may allow for recharge of the watershed to North Pond.

The JWD is operated as an Enterprise Fund, with annual operating revenue of approximately \$1.4 Million and annual expenses typically around \$1.1 Million. The remaining revenue is used for debt service. The JWD bills residential and commercial customers quarterly. Current rates, which went into effect in June 2022, are as follows:

Table 5
WATER RATES - MINIMUM IN ADVANCE CHARGES
 Source: Jamestown Water Department

Meter Size	Quarterly Billing Rates	Seasonal Billing Rates	Miscellaneous Charges
5/8"	\$89.82	\$340.84	Turn-on/off \$30.00
3/4"	\$134.80	\$511.59	Install/Remove \$100.00
1"	\$167.42	\$635.36	Early Install/Remove \$50.00
1-1/2"	\$206.22	\$781.78	Sprinkler Charge/unit \$0.18
2"	\$268.63	\$1,019.50	Frozen Meter Charge \$125.00
3"	\$495.25	\$1,879.56	Special Reading \$20.00
4"	\$745.46	\$2,828.23	Call Out \$150.00
			Lien Discharge Recording Fee \$49.00



Table 6
CURRENT EXCESS WATER RATES

Source: Jamestown Water Department

Gallon Tier Structure		Rate per 1,000 Gallons
0	5,000	\$0.00
5,001	9,999	\$7.98
10,000	14,999	\$8.58
15,000	19,999	\$10.87
20,000	49,999	\$15.13
50,000	99,999	\$18.56
100,000	199,999	\$23.76
200,000	999,999,999	\$30.24

Table 7
EXCESS SEASONAL WATER RATES

Source: Jamestown Water Department

Minimum	Maximum	Rate per 1,000 Gallons
0	20,000	\$0.00
20,001	49,999	\$15.13
50,000	99,999	\$18.56
100,000	199,999	\$23.76
200,000	999,999,999	\$30.24

Coordination

The 2015 Jamestown Comprehensive Plan, which was adopted by the Jamestown Planning Commission and Jamestown Town Council on June 18, 2014, was reviewed while updating this WSSMP and it is the intent that this WSSMP be consistent with the goals and policies of the Town’s Comprehensive Plan.

The Preamble to the Comprehensive Plan identifies that the driving theme of the plan is to maintain the town’s rural character. The Comprehensive Plan also indicates that the “Center Island Watershed should continue to be protected. Development should not exceed on-island natural supplies of water. Conservation of existing water supplies should continue to be emphasized, as well as finding new methods to supplement the existing yield.” The Comprehensive Plan lays out a number of goals and recommended actions in order to protect the quality and quantity of the potable water resources on the Island. The JWD acknowledges and supports these goals and recommended actions.

The JWD has a non-permanent emergency interconnection with the Town of North Kingstown and maintains a close working relationship with the Town with regard to the maintenance of the



emergency interconnection. The JWD also coordinates with the local fire department to track water usage for firefighting and training exercises. The JWD estimates that approximately 100,000 gallons of water is used annually by the fire department.

Municipal wastewater collection and treatment, in addition to water supply, is provided by the water and sewer division of the town's Department of Public Works. The Jamestown Town Council sits as the Board of Water and Sewer Commissioners. Joint billing is not currently in place but may be a future consideration in Jamestown.



SECTION 1.0 GOALS STATEMENT

The overall goal of this 5-year update to the Water Supply System Management Plan (WSSMP) for the Town of Jamestown Water Department (JWD) is to provide a document that complies with the provisions of the Water Supply System Management Act. Ultimately, it provides a comprehensive analysis of past years in order to establish the water system's needs in the future. Appendix A includes the worksheets that accompany this WSSMP, current and projected data applicable to the system.

This document is intended to comply with the provisions of the latest edition of the Rules and Procedures for Water Supply System Management Planning (490 RICR-00-00-2) and the Water Use and Efficiency Rule for Major Public Water Suppliers (490 RICR-00-00-1). These rules were promulgated in accordance with Chapter 42-35 pursuant to Chapter 46-15.3 of the Rhode Island General Laws, as amended.

1.1 General JWD Goals and Objectives

The JWD's primary objective is to operate a water system for the benefit of and to meet the legitimate needs of, the customers in its service area. In accordance with that objective, the JWD's specific goals are to:

1. Protect the integrity of the watershed, by preventing potential pollutants from entering the water distribution system.
2. Maintain or increase the available water supply to meet existing and future demand.
3. Promote the efficient use of water through:
 - a. Conservation and efficient operation of the system in accordance with industry and State standards; and
 - b. Effective metering and public information programs that encourage water conservation.
4. Plan for future development such that the water supply system is not extended beyond its capacity, in order to provide safe, clean drinking water.
5. Maintain and upgrade the distribution network to decrease the volume of unaccounted water.
6. Investigate alternatives to increase the safe daily yield of the water system.
7. Regulate expansion of municipal water service.
8. Comply with all applicable laws and regulations.
9. Conform to the overall goals for water suppliers established in State Guide Plan Element No. 721 – Rhode Island Water 2030.

1.2 State Guide Plan Element 721 - Rhode Island Water 2030

Goals and objectives specific to public water suppliers are outlined in State Guide Plan Element 721, Rhode Island Water 2030, and are summarized below. The vision of Rhode Island Water 2030 is “to ensure safe, reliable, ample water supplies to meet the State's short and long-range needs while preserving the physical, biological, and chemical integrity of the water resources of the State.”



The goals of this WSSMP are consistent with those of Rhode Island Water 2030, as follows:

Integrated Management and Planning Goals

IMP-1: Integrate water resources and supply planning for water systems across intergovernmental and regional jurisdictions.

IMP-2: Ensure the adequate technical, managerial, and financial capacity of water systems.

IMP-3: Manage and plan for water systems that support sustainable, compact land use and concentrate development within the urban service boundary and/or growth centers.

Water Resource Management Goals

WRM-1: Manage and plan for the sustainable water use and development of the water resources of the State.

WRM-2: Protect and preserve the health and ecological functions of the water resources of the State.

WRM-3: Ensure a reasonable supply of quality drinking water for the State.

WRM-4: Ensure the protection of public health, safety, and welfare and essential drinking water resources during water supply emergencies.

1.3 RIWRB Strategic Plan

The Rhode Island Water Resources Board (WRB) established a Strategic Plan in 2012 to articulate a strategy of achieving its primary duty, which is to "...regulate the proper development, protection, conservation and use of the water resources of the State". These actions form the WRB's four primary goals for managing the water resources of the State. The JWD shares these goals and operates the water system with those in mind. This WSSMP is intended to be consistent with these objectives.



SECTION 2.0 WATER SUPPLY SYSTEM DESCRIPTION

Background

The Town of Jamestown Water Department was established by special act of the General Assembly of the State of Rhode Island in March of 1969 to provide for a public water supply to the Town of Jamestown. However, the water system on the island dates to 1890. This system was limited to the Village area of Jamestown and did not service the entire Town. It was owned and operated by the Newport Water Works Corporation until 1940 when ownership was passed to the Jamestown Water Company. Before 1969, ownership of the water system was by private entities. Legislation establishing the public water supply in Jamestown is provided in Appendix B.

Source of supply, dating to the original development of the system, has been from surface waters impounded in two reservoirs, Carr Pond (North Pond) and Watson's Pond (South Pond), which were constructed in 1901 and 1909, respectively. Storage capacity was increased at Carr Pond, the main supply source, in 1927 by raising the embankment height.

A water treatment plant was installed circa 1920 which included the conventional processes of coagulation, flocculation, sedimentation, and filtration. Subsequently, in the 1950s, the treatment process was expanded to include the addition of chlorine, chlorine dioxide, aluminum sulfate (alum), and lime.

By 1950, it was estimated that the system served approximately 2,000 year-round residents and up to 4,000 variant summer residents in the southern portion of the Town, south of Route 138. The distribution system consisted of upwards of 12.5 miles of pipeline ranging in size from 4 to 12 inches and was constructed predominantly of cast iron (unlined) and cement pipe. At that time the system had one storage tank, constructed in 1914 with a capacity of 360,000 gallons. Pressures in the system ranged from 30 – 60 psi. It has been reported that average daily demand ranged from 0.10 to 0.33 million gallons per day (MGD), with a maximum day demand of 0.586 MGD.

A water treatment and filtration plant with automated controls was constructed in 1991. Treatment processes at this plant included upflow clarifloculator filtration package units, pH adjustment, disinfection, and corrosion control. This treatment plant has since been replaced with a new, state-of-the-art membrane filtration plant that was put into service in 2010. There is also a pre-treatment facility at South Pond, capable of pre-treating between 180,000 and 350,000 gallons of raw water per day with pH adjustment and chlorine dioxide (ClO₂) bleaching for odor, color, and taste. Treated water is pumped from the treatment plant to two 1.0 MG standpipes for distribution into the system.

2.1 Organization and Legal Structure

The Town of Jamestown owns, operates, and maintains a water distribution system that serves approximately 3,323 customers in town. The Town operates under the Council-Administrator form of government. The Town Council, which sits as the Board of Water and Sewer Commissioners (Board), is the governing body of the Town's water supply. The Board creates and administers public water policies through the Town Administrator and Public Works Director who is the head of the Water Department. The Public Works Department, Town Engineer, and Water Division personnel are responsible for the full implementation and operation of the public water supply. Figure 2.1, provided on the following page, is the organization chart for the Town's Water Division.



Town of Jamestown Organizational Chart

Figure 2.1

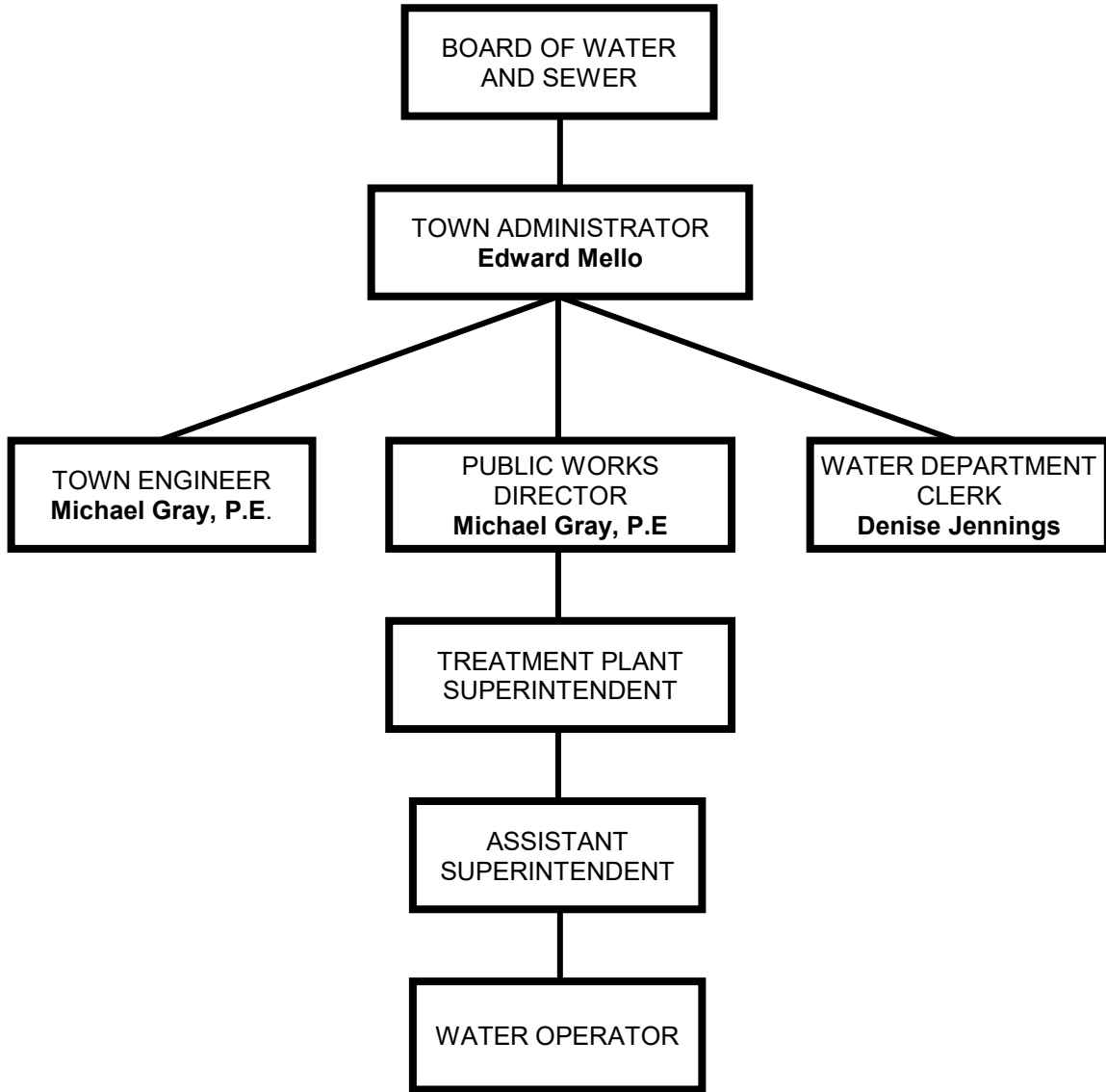

BOARD OF WATER AND SEWER

(Jamestown Town Council)

Nancy Beye, President

Mary Meagher, Vice President

Erik Brine

Michael White

Randall White

The Water Division, under the direction of the Public Works Director, is responsible for the maintenance and operation of all physical facilities related to water supply, treatment, and delivery. The Water Division has three full-time employees. In addition to the Public Works Director, there is one other staff member at the managerial level. The Treatment Plant Operator must meet state certification requirements. The water system is designated by the State of Rhode Island Department of Health as #1858419.

2.2 System Description

The system consists of two surface reservoirs, a treatment plant put into service in 2010, a pretreatment facility at South Pond, two bedrock supply wells, one pumping station, two water storage facilities, and the distribution piping network. Distribution piping consists of approximately 20.5 miles of mostly 6- and 8-inch water main. The current system was largely developed and expanded over time from the original system of the 1890s.

The service area for the public water supply is the Village area of Jamestown. This area consists of commercial and more densely developed residential properties within Jamestown. Water distribution piping was developed and extended to Fort Wetherill, Fort Getty, and Beavertail located south of the urban district when there was a military presence in Jamestown. This area is referenced as the rural district and over time residential properties were permitted to connect in this district. Water service connections in the rural water district are subject to the approval of the Town’s Board of Water and Sewer Commissioners and must be consistent with the Comprehensive Community Plan.

2.3 Supply Sources

2.3.1 Surface Water Supply

Jamestown's surface water resources consist of two surface reservoirs, located within a single watershed. Nearly 99% of the water is surface runoff, with a minimal portion coming from underground springs. Total land area comprising the watershed is 640 acres. The watershed is located in the central portion of Conanicut Island. Land use in the watershed is primarily low-density residential. The following is a breakdown of the surface water sources, including safe yield estimated from a Safe Yield Analysis performed by Fay Spofford & Thorndike in 2000. Supplemental water from South Pond can be transferred to North Pond but only when water is flowing over the dam at South Pond.

<u>Reservoir</u>	<u>Area</u>	<u>Usable Capacity</u>	<u>Safe Yield</u>
North Pond	25.4 Acres	60 MG	194,000 gallons/day*
South Pond	4.67 Acres	8 MG	89,000 gallons/day

South Pond has not been used for a number of years due to water quality concerns. The new treatment plant was designed with the ability to treat water from South Pond but the treatment process is inefficient due to the amount of sludge generated. *Currently, JWD is using the safe yield for North Pond of 185,000 gpd as a result of the RIDEM analysis and Drought of Record. South Pond is not available during dry periods and is only used to transfer water to North Pond when water is flowing over the South Pond dam.

North Pond, also known as Carr Pond, is located near the intersection of North Road and Route 138 and has a watershed area of 192 acres. Its total capacity is 70 million gallons (MG) with a net



usable volume of 60 MG. South Pond, referred to as Watson Pond, is located just north of Great Creek on the western side of North Road. It receives excess spillover from North Pond plus runoff from an additional 449 acres of watershed area. Its usable capacity is approximately 8 MG and a total capacity of 10 MG.

Water quality in North Pond has historically been better than South Pond and is used as the primary supply to the system.

There are currently no requirements from any state agencies imposing minimum downstream discharge release from either of the two surface water supplies. No such future requirements are envisioned at this time.

2.3.2 Groundwater Resources

The subterranean composition of Conanicut Island is bedrock and glacial till. In an effort to augment Jamestown's water supply, two deep bedrock wells (JR-1 and JR-3) were drilled to the south of North Pond with capacities ranging from 45,000 to 55,000 gallons per day (gpd). Water from JR-1 and JR-3 is pumped directly into the transmission main between North Pond and South Pond at rates up to 50 gpm. Both JR-1 and JR-3 are limited, per the Rhode Island Department of Environmental Management and the Rhode Island Department of Health, to a 48-hour operating cycle, which alternates both wells. A detailed description of each facility is provided in Worksheet No. 2.

2.4 Infrastructure Components

2.4.1 Water Treatment

Raw water from North Pond flows through a 7,500-foot long, 10-inch PVC pipe to the pumping/pretreatment station located at South Pond (Reference Map 1). The pump station can pump from either the North Pond pipe or directly from South Pond, depending on the level in the reservoirs. At this stage, the water supply receives primary treatment in the form of chlorine dioxide to kill bacteria and microorganisms at a pre-treatment facility before it is pumped to the primary water treatment facility. Worksheet No. 5 provides additional information relative to the raw water pump station.

A new, state-of-the-art treatment facility was constructed and put into service in May 2010 on the site of the pre-existing treatment facility on North Road. The prior treatment facility last underwent significant renovation and upgrades in 1991, but the new treatment plant was constructed with higher treatment capacity (500,000 gallons per day), improved finished water quality, and to lower backwash water requiring discharge to Great Creek.

The raw water wetwell of the 1991 treatment facility remains in use. Raw water enters this wetwell where it passes through a basket screener before flowing into a chemical mixing tank for pH adjustment (potassium hydroxide) and coagulant (alum) addition. Flow splits to parallel treatment trains consisting of coagulation basins and membrane filtration basins. Treated water is stored in an underground clearwell original to the 1991 treatment facility, and then is pumped from a transmission pump station located on North Road. The storage capacity of the clearwell is 38,000 gallons. Additional information on the treatment facilities in use in the system is provided on Worksheet No. 3. Figure 2.2, provided on the following page, is a flow diagram of the processes at the new treatment plant.



2.4.2 Storage Facilities

The system contains two 1.0 MG steel standpipes located on Howland Avenue. The original tank (South Tank) was constructed in 1974. . It was most recently inspected in 2019 and is typically inspected every five years. The other standpipe (North Tank) was constructed in 2007 to provide supply redundancy to help correct fire flow deficiencies and increase emergency storage, while also providing more flexibility for tank maintenance. It was most recently inspected in 2013. The exteriors of both tanks were repainted in 2023.

Both tanks have a 41-foot diameter, height to overflow of 101 feet, and usable capacity of 700,000 gallons. The system operates as a single pressure zone set by the elevation in the two standpipes.

The JWD installed a transfer pumping station between the two tanks to take advantage of the water stored in the bottom of each standpipe that would otherwise not be considered usable storage. Additional information is provided on Worksheet No. 4.



Figure 2.2 Treatment Plant Process Flow Diagram

GENERAL NOTES

1. SEE SHEET M-1 AND M-2 FOR THE SYMBOL AND ABBREVIATIONS LEGEND
2. THIS PLAN IS TO SHOW PROCESS FLOW AND GENERAL ARRANGEMENT OF THE PLANT. NOT ALL PIPING AND VALVING IS SHOWN FOR CLARITY.
3. CHEMICAL FEED PIPING ARRANGEMENTS ARE SHOWN ON M-7 AND M-8
4. AIR COMPRESSOR EQUIPMENT, PIPING AND APPURTENANCES SHOW ON M-9

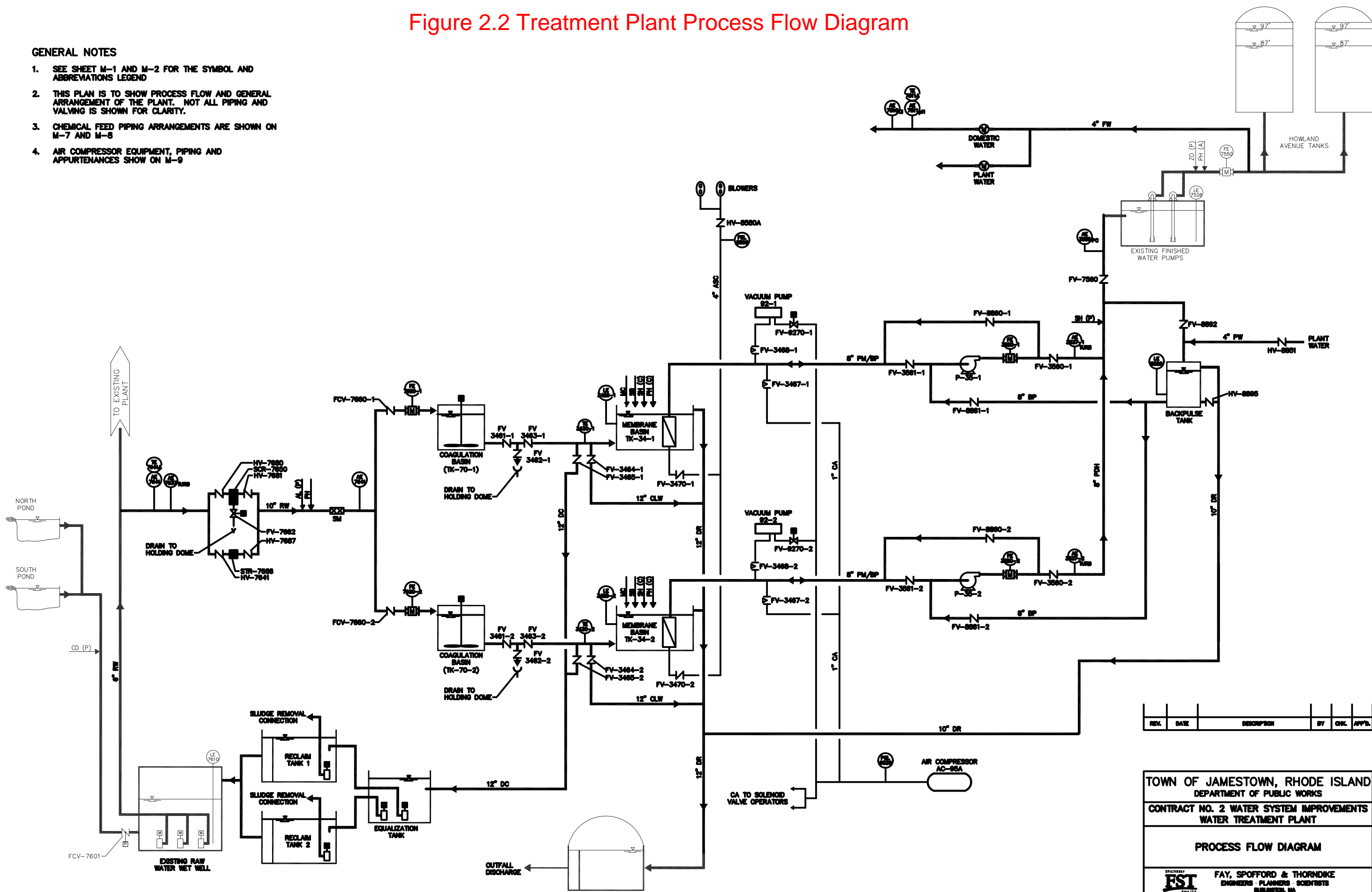

REV.	DATE	DESCRIPTION	BY	CHK.	APP.

TOWN OF JAMESTOWN, RHODE ISLAND
 DEPARTMENT OF PUBLIC WORKS
 CONTRACT NO. 2 WATER SYSTEM IMPROVEMENTS
 WATER TREATMENT PLANT

PROCESS FLOW DIAGRAM

ENGINEERS
FST
 FAY, SPOFFORD & THORNDIKE
 ENGINEERS · PLANNERS · SCIENTISTS
 BURLINGTON, MA

FS&T PROJECT NUMBER WJ-007	SCALE: NONE DATE: MARCH 8, 2007	DES. DR.	CHK. DR.	APPROVED JDO
--------------------------------------	------------------------------------	----------	----------	-----------------

S:\wjt-007\Contract 2 - WTP\CADD\MECH\W007-M3.dwg 03/19/07 07:37 [19:32] By benet_d

2.4.3 Pumping Station

The JWD has one finished water booster pump station, located on North Road. The pump station has two, 350 gpm pumps that are used to fill the two standpipes on Howland Avenue.

2.4.4 Transmission Mains

Including connections from the reservoirs to the treatment plant, there are five distribution lines in Jamestown that are categorized as transmission mains. They are listed on Worksheet No. 6 in Appendix A and are summarized below:

North Pond to South Pond - 7,500-foot, 10" PVC water main constructed in 1980 that is in good condition.

South Pond to Treatment Plant - 2,600-foot, 10" asbestos cement (AC) water main constructed in 1975 that is in good condition.

Weeden Lane - 2,250-foot, 10" PVC water main constructed in 1980 that is in good condition.

East Shore Road - 3,000-foot, 10" PVC water main constructed in 1991 that is in good condition.

Howland Avenue – This line was replaced in 2005 with a 12-inch DI pipe and the 2,500-foot section is in excellent condition. This transmission main connects the standpipes to the distribution system.

2.4.5 Distribution System

The JWD water distribution system consists of approximately 21 miles of water main. Distribution mains are a combination of cast iron (CI), polyvinyl chloride (PVC), cement-lined ductile iron (DI), and asbestos cement (AC) pipe. Distribution pipe sizes are either 6-inch or 8-inch in diameter. The majority of these pipelines are less than 25 years in age. New and replacement mains consist predominantly of PVC pipe.

Generally speaking, the majority of the distribution piping is in good condition. Still, the JWD has replaced over 8,000 linear feet of pipe in the distribution system since 2005. Recent water main replacement projects the JWD has completed include the following:

- Racquet Road: Installed 1,500 feet of 6" water main to eliminate a 2" water service line to multiple homes.
- Hull Cove Farm Road: Replacement of 1,400 feet 4" water main with new 6" PVC water main.
- Replaced 300 linear feet of 6" CI water main on Conanicus Avenue at East Ferry with 8" PVC water pipe.
- 2023 completion of design, permitting, and bid documents for two distribution replacement projects that have received funding:
 - To replace 3,000 linear feet of 6" CI water main with 12" DI water pipe within Narragansett Avenue.
 - To replace 3,000 linear feet of 6" CI transmission main in North Road between the water treatment plant and the village water district with a 12" DI water pipe.



These pipe replacement projects are part of an overall distribution system upgrade program the JWD is implementing to correct fire flow deficiencies and address transmission deficiencies while also replacing aging components. The program consists of pipe replacement and pipe cleaning and lining. The timeline is over an approximate 20-year period.

2.5 Interconnections

JWD is currently waiting for approval from the RIDOH on a permanent emergency interconnection with North Kingstown. The connection would be a 6-inch flexible water line that runs from a hydrant on Tashtassuck Road in Jamestown to a hydrant on Lorelei Drive in North Kingstown. The flexible water line consists of three, 2,500 linear-foot trailer-mounted hose reels, which can be installed by driving the trailer from the Jamestown hydrant across the Jamestown Verrazano Bridge to the North Kingstown hydrant. Purchase of water via the interconnection is limited strictly to emergency and can be made available by contacting the Director of Water Supply for the Town of North Kingstown. The system operates by gravity since the hydraulic grade of the North Kingstown water system is greater than that of the Jamestown Water System.

The cross-connection to the North Kingstown water system has the capacity to supply water at the rate of approximately 150 gpm (0.216 MGD). However, the North Kingstown – Jamestown Water Agreement (Appendix C) mandates that no more than 200,000 gpd may be purchased, at the sole discretion of the Director of North Kingstown’s Department of Water Supply. However, this quantity alone is sufficient to meet Jamestown’s demands during months of low water consumption as well as under emergency conditions. Worksheet No. 7 provides additional information relative to this interconnection.

The most recent use of the interconnection occurred in 2002 when Jamestown utilized approximately 0.91 MG from North Kingstown. In January 1994, the Water Division operated solely on the North Kingstown connection while repairs were enacted to their storage tank and other system components. From the first day of operation, this connection has been an operational success, and has helped to alleviate the burden on North Pond. The Water Department has annually renewed its agreement to purchase water from North Kingstown. It is expected that this agreement will continue as long as the connection remains active.

2.6 Service Area

2.6.1 Geographic Area

Jamestown is confined to Conanicut Island, located at the mouth of Narragansett Bay. Access to the island occurs either by the Jamestown Bridge, which connects Jamestown’s western shore to the Town of North Kingstown, or by the Newport Bridge, which provides access to and from the City of Newport, which is also located on an island in Narragansett Bay.

The service area is located entirely within the Town of Jamestown and is confined predominantly to the Village and Beavertail sections of the town. The Water Regulations adopted by the Board of Water and Sewer Commissioners define the district as follows:



"Urban Water and Sewer District" shall refer to all the land in the Town of Jamestown bounded to the north by a line running east along the north property line of Plat 8, Lot 30 from the West Passage of Narragansett Bay extended to Arnold Avenue and continuing east on Arnold Avenue to North Road, then north on North Road to Whittier Road, then east on Whittier Road to Prudence Lane, then south on Prudence Lane to Bryer Avenue, then east on Bryer Avenue to Calvert Place, then north on Calvert Place to Mount Hope Avenue, then east on Mount Hope Avenue to Bayview Drive, then north on Bayview Drive to property line of Plat 8, Lot 645 to the East Passage of Narragansett Bay and bounded to the south by the water shut-off at the Mackerel Cove Beach House running east along Hamilton Avenue right-of-way and along the northern edge of Plat 9, Lots 827 and 324, extended east to the East Passage of the Narragansett Bay, and further defined as that land which is encompassed within the area shown and designated as the Urban District on the Urban and Rural Water and Sewer District Map. All references to roadway boundaries are defined as the centerline of the roadway.

Figure 2.3 shows the boundaries of the Urban Water and Sewer District. Extensions of water service have been made beyond this District. These additions include service to the Beavertail area (Rural Water District), and water line extension to the Dumplings Area. No future extensions of water service are planned at this time.



Legend

-  Jamestown
-  Urban Water & Sewer District
-  Rural Water District

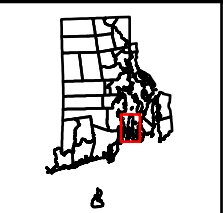
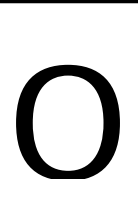
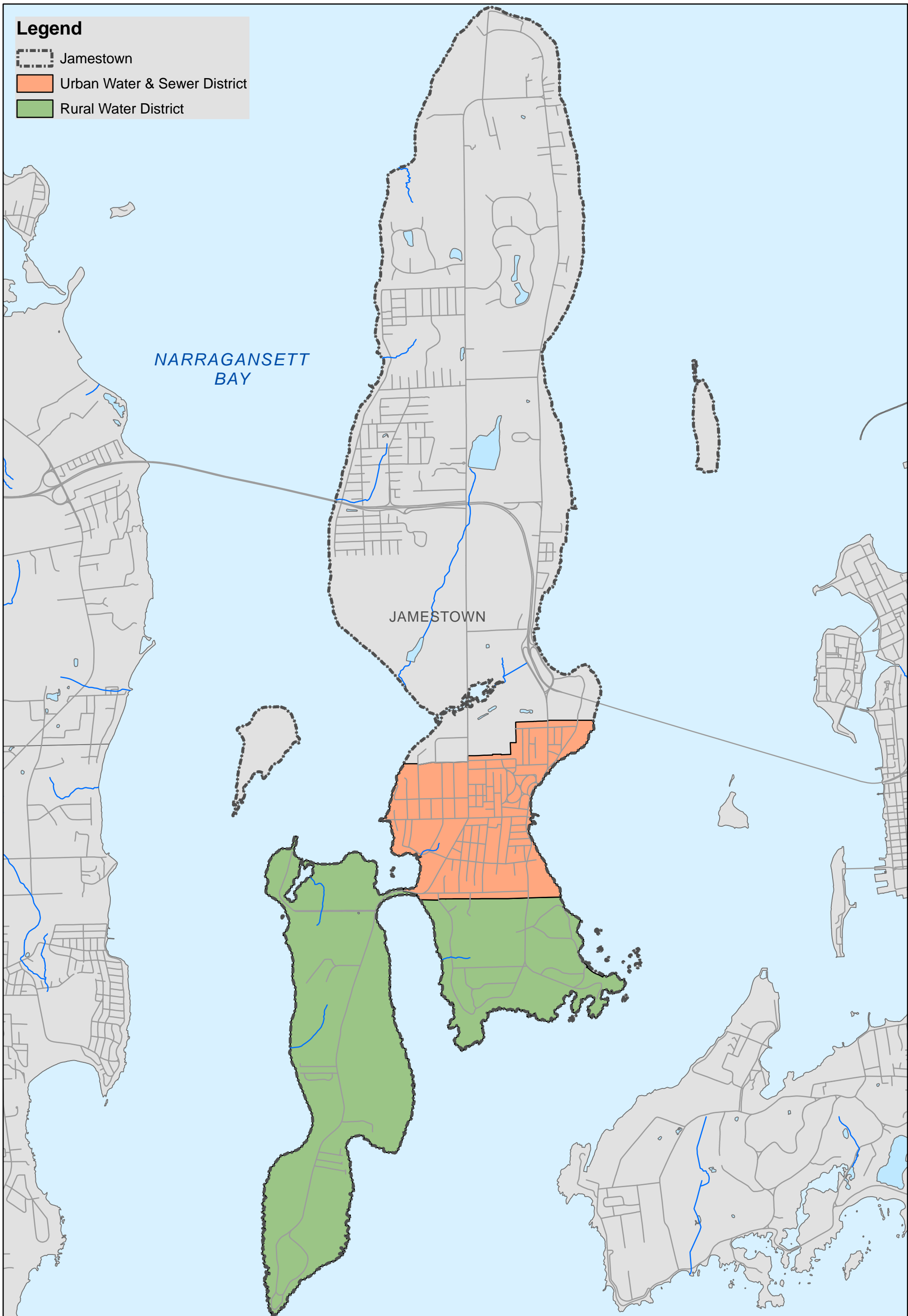

JAMESTOWN PUBLIC WATER AND SEWER SERVICE AREA (EXISTING)

1" = 3,000'
0" 1"
BAR IS ONE INCH ON ORIGINAL DRAWING

PROJECT NO.:	17103.04
DATE:	APRIL 2024
SCALE:	AS NOTED
DRAWN BY:	SJP
APPROVED BY:	JA

FIGURE 2.3

Areas outside the Water District, where water lines are currently located, are eligible for connection. Any water service connection in this area outside of the District is subject to the approval of the Town's Board of Water and Sewer Commissioners and must be consistent with the Comprehensive Community Plan. Section 13 discusses Jamestown's Comprehensive Plan as it pertains to the Water District.

2.6.2 Present and Historic Water Services

There currently are 1,420 residential services in the system. Additionally, there are 96 commercial and 32 governmental service connections in the system. There are no industrial water users in Jamestown. The sewage treatment plant is a governmental customer and four marinas that operate in Jamestown are treated as commercial customers. There is no true industrial type of establishment in Jamestown.

2.6.3 Population Served

The total population of Jamestown was estimated to be 5,538 in the 2022 U.S. Census, an increase from 5,405 people in 2010. Recent US Census Data suggests that there are approximately 2.34 people per household throughout Jamestown. The current population in the JWD water system service area is estimated to be 3,323.

2.6.4 Population Distribution and Future Land Use

The JWD service area is comprised of an Urban Water and Sewer District which comprises the "Village" part of Town and a Rural Water District that encompasses Rural Residential area in the southern part of Town, including the Beavertail section of Jamestown. A considerable portion of Jamestown's population resides outside of the water system service area.

A large percentage of this resides in the Jamestown Shores area, which has relatively dense development but is not currently served with water or sewer. Jamestown Shores is along the west side of the island, primary north of Route 138. The remaining population resides in rural areas in the far north and northeast parts of Jamestown.

Urban Water District

Under the Urban and Rural Water District Regulations adopted in 1986, the Town has specific guidelines for new connections to the water system. Service connections for use other than one or two-family homes require approval of the Board of Water and Sewer Commissioners. Applicants must show to the satisfaction of the Board that the request for service:

- 1) is consistent with the Comprehensive Community Plan;
- 2) will not impair available resources of the Urban Water District;
- 3) will not reduce the level of fire protection; and
- 4) will not reduce the quality or quantity of water provided to existing users.

Property owners whose land is within the district or which has frontage on a district boundary road may request a water service connection. Because of the relatively small supply capacity of the system, no expansion of the Urban Water District is planned or anticipated at this time. Extension of water service within the Urban Water District is typically only granted when it provides a greater benefit, such as bringing fire protection to an area that currently does not have it.



Jamestown Shores Neighborhood

From time to time, the issue of water service to the Jamestown Shores area is raised. This area was subdivided in the 1940s into very small lots, and most are less than a quarter acre in size. The area is zoned R-40, which requires 40,000 square-foot lots but many of the lots do not meet this and are developed in accordance with the original subdivision. Over time, the area has transitioned from small seasonal homes to larger, year-round homes. There is currently no public water service available in the area, and each lot has its own private well and onsite wastewater treatment system (OWTS). This factor, coupled with poor soil conditions, creates the potential for groundwater quality concerns. Figure 2.4 depicts Jamestown Shores and other areas of Town.

Should water quality issues become evident in Jamestown Shores, measures may be needed to provide potable water to the area. This scenario would exact a severe financial and service burden on the Water Department. New transmission lines, pump stations, and a standpipe would be required. Also, it is unlikely that existing supply sources would be sufficient and questionable that sufficient raw water could be found on the island to meet this increased demand.

At this time there are no indications that groundwater quality has deteriorated to any significant degree that would suggest expansion of the water service area is warranted. Also, the Jamestown Comprehensive Plan indicates that extension of services to this area of Jamestown is not currently being considered. Therefore, it is imperative that the Town of Jamestown makes every reasonable effort to ensure that water quality in the Jamestown Shores area is maintained. Steps that the Town has considered and begun to implement in order to minimize health risks associated with this area include:

- Monitoring RIDEM's granting of OWTS permits in the area;
- Require maintenance of existing septic systems;
- Create a soils overlay district and prohibit OWTS where severe limitations exist;
- Strictly enforce local regulations on OWTS setbacks from wetlands; and
- Encourage property owners to consider alternative OWTS technology where appropriate.

2.7 Source and Distribution Metering

The JWD meters 100% of the water distributed to its customers. Water use is metered and billed on a quarterly basis.

The interconnection with North Kingstown is metered at both ends of the pipeline when in use, which allows leakage to be immediately detected and repaired. There also is one master meter in the system, located at the new treatment plant and described further on Worksheet No. 8. There are no major users in the system. Therefore, Worksheets Nos. 9 and 10 are not applicable to the JWD.



Figure 2.4

Land Areas

**TOWN OF
JAMESTOWN
RHODE ISLAND**

Comprehensive Plan, 2014

Map Legend

-  Roads
-  Highways
-  Streams
-  Jamestown Shores
-  Conservation Area
-  Rural Residential
-  The Village
-  Waterbodies

Source:
RIGIS, E911 Roads,
& The Town of Jamestown

This map is not the product of a Professional Land Survey. It was created by Jamestown GIS Department for general reference, informational, planning or guidance use, and is not a legally authoritative source as to location of natural or manmade features. Proper interpretation of this map may require the assistance of appropriate professional services. The Town of Jamestown makes no warranty, express or implied, related to the spatial accuracy, reliability, completeness, or currentness of this map.



Justin Jobin
Jamestown GIS Dept.
May 2014



0 0.25 0.5 1 Miles

2.8 System Production Data

The JWD obtains its water supply primarily from North Pond with relatively little from well JR-1. South Pond and well JR-3 are typically not used under normal conditions but are also available supply sources and are protected and maintained as such. For 2022, water withdrawn from North Pond was 53.60 MG and 7.57 MG from Well JR-1 for a total of 61.17 MG. The JWD does not typically buy water from, or sell water to, other water systems at wholesale. JWD recently discovered a reporting error with the computation of the total production flow data in the system. Flow data is metered at the water treatment plant and includes flows from both the North Pond and well JR-1 production sources. JWD was also reporting the metered flow from well JR-1 separately and as a result was double counting the flow from well JR-1 in the annual reporting spreadsheets. JWD has corrected this going forward for future annual production flow reporting.

Total water production for 2022, based on withdrawals from available sources, was 61.17 MG. This is less than the water use over the last five years with the exception of 2021 (71.10 MG). Another exception to this was a relatively high withdrawal rate in 2010, which is attributed to the startup and testing of the new water treatment facility. In comparison, water withdrawn from all sources from 2017 to 2021 was reported to be 68.20 MG on average.

2.9 System Water Use

2.9.1 System-Wide and Per Capita Water Use

Worksheet No. 15 presents the Average Day Demand (ADD) based on water withdrawn from JWD's sources (North Pond and Well JR-1). The ADD for 2022 was 0.168 MGD and per capita ADD was 50.4 gallons per person per day, each based on water withdrawn from the JWD's sources and not metered water use. The per-capita ADD estimates are based on an approximate service area population of 3,323 for each month of the year. It is acknowledged that part of the JWD's service population is seasonal but accurate estimates of how the population varies throughout the year are not currently available. With that said, water use increases in the summer and the ADD for July and August 2022 was approximately 0.245 MGD.

Worksheet No. 15 also presents the Maximum Day Demand (MDD) based on water withdrawn from JWD's sources (North Pond and Well JR-1). The MDD for 2022 is estimated to be 0.336 MG using a multiplier of 2.0 applied to the ADD, which is an assumption that has traditionally been used by the JWD. Peak hour demand data is not available.

2.9.2 Water Use by Category

Table 4.2 provides water use by category (residential, commercial, and government) based on quarterly meter readings for Fiscal Year 2022. The majority of water use was residential, approximately 47.81 MG or 89% of the 53.90 MG total used for the year. Commercial and governmental water use was approximately 7.8% and 3.5% of total water use in 2022, respectively.

Worksheet No.15 shows the 5-year and 20-year ADD and MDD water withdrawn values that will increase from the 2022 values based on the increased service area population outlined in the 2024 build-out analysis (Appendix J). These values are currently lower than the current 0.233 MGD source total water available for ADD but not MDD. For future service area population growth, it is important that JWD finds additional sources of water. The non-billed and non-metered flows are presented in Worksheet No. 11. The combined non-billed and non-metered flow for 2022 was estimated to be 7.27 MG. Worksheet No. 12 and Table 4.4 depicts the 5-year and 20-year projected



metered flows for the JWD system based on the recent 2024 build-out analysis. Table 4.2 shows the current metered flows based on the 2022 JWD annual report flow data as well as the service area population growth projection that is based on current US Census data and RI Division of Statewide Planning population growth data.

2.9.3 Major Users

The regulations define major users as any user who consumes in excess of 3 million gallons per year. There are no major water users in Jamestown. Worksheets Nos. 9, 10 and 13 are not applicable for this WSSMP.

Legal Obligations to Provide Water

The Town of Jamestown is obligated to supply drinking water to properties located within the Urban Water District. The Town has recently adopted regulations regarding future connections to municipal water and sewer. Jamestown has no obligations to provide specific quantities of water to any private or public water users or any other water systems.

2.9.4 Non-Account Water Use

Non-account water use consists of the difference between the volume of water metered at the point of supply, and that recorded at all points of sale. This non-account water typically consists of water consumed for both authorized and unauthorized uses. Authorized uses include firefighting, water main/storm drain flushing, sewer/street cleaning, landscaping in public areas, etc. It also includes water that is metered but not billed, and therefore is not reflected in the recorded volumes of water sold. Unauthorized uses may include system leaks, malfunctioning meters, meter pit bypasses, and water theft.

Table 2.1 summarizes non-account water use accounted for in the system for the most recent year, and Worksheet No. 11 provides non-account water for 2022 and the 5-year and 20-year projections (2027 and 2042, respectively). For now, the 5-year and 20-year non-account projections were assumed to be the same as Fiscal Year 2022. Non-account water that was accounted for was estimated to be approximately 7.27 MG in 2022.

Table 2.1
TYPICAL ANNUAL NON-ACCOUNT WATER USE (MG)

Firefighting	0.1
Main Flushing/System Maintenance	0.1
Storm Drain Flushing,/Sewer/Street Cleaning/Landscaping	0.015
Leakage	1.0
Process Water at Treatment Plants	6.05
Total	7.27

Fire Protection

Fire protection for Jamestown is offered by a volunteer fire department located on Narragansett Avenue. Water use at the fire station is metered. Response to fire emergencies requires personnel to utilize whatever water source is most readily available. Water used for firefighting is drawn from equipment tanks, hydrants, Narragansett Bay and freshwater ponds.



Average non-account water use by the fire department is approximately 100,000 gallons annually. This is used for drills, annual training, and distinguishing small fires.

Leakage

Total non-account water was estimated to be approximately 7.27 MG in 2022, which represents 11.88% of the total water withdrawn from North Pond and Well JR-1. For 2022, leakage was estimated to be 1.0 MG, or approximately 1.6% of total water use in the system.

Over the past several years, significant effort has been made to reduce water lost resulting from leakage in the distribution system. The JWD routinely checks areas where leaks have been detected in the past. Rusty water complaints are also investigated and water mains are checked. The JWD has their own leak detection equipment that they routinely use; however, leaks are often discovered quickly as the geological composition of the island results in water rising to the ground surface.

Many of the older distribution lines most at risk for leaks in Jamestown have been replaced in recent years. The reduction in non-account water since the early 2000s is attributed in part to a vigorous leak detection program as well as transmission main upgrades performed by the JWD.

Quantifiable Water Uses at the Treatment Plant

Water quality testing and plant processing volumes are necessary uses of finished water needed to ensure a continuous supply of high-quality drinking water for JWD customers. In the past, water drawn for finished-quality testing had been taken from a fixture located at the former treatment plant which ran constantly at the rate of 5 gpm (2.63 MG per year). The rationale of the JWD personnel for running the water at all times was to ensure continuous flushing so that water tests would accurately reflect water quality in the transmission main. This is not the current practice at the new treatment plant and water use for water quality testing has been reduced.

The production of potable water from the surface reservoir requires that a certain volume of water be used for processing. A relatively high volume is used at the plant due to the high level of organic matter in raw water, and the treatment plant requires an average of 1.5 MG of finished, metered water for processing each year. The primary use of this water is for cleaning equipment.

2.10 Water System Deficiencies

The primary deficiency in the JWD system is the lack of supply. Otherwise, the system has been well maintained.

Upgrades to the system that have been completed in recent years and underway include the following:

Reservoirs

- Completed improvements to the 850-foot earthen dam at North Pond with the installation of a toe drain along the entire length.
- Filled and re-graded the face of the entire earthen dam to improve the slope and stability of the structure.
- Replaced compressed air with a high-volume blower for the diffused aeration system within the reservoir that was used to improve raw water quality.



-
- Design and permitting drawings are complete for the reconstruction of the South Pond earthen dam project. The project is funded, and the construction schedule will be determined in the future.

Well JR-1

- Installed new PLC and controls for the wellhead.
- Replaced well pump and constructed well house over the well standpipe for protection.
- Installed 700 linear feet of well piping beneath grade from the wellhead to the transmission main connection to protect the line from freezing so that the well can be used year-round.

South Pond Transfer Pump

- Reconstructed the pump skid and installed new pumps to transfer water from South Pond to North Pond to increase the available supply at the reservoir.

South Pond Pretreatment Building

- Installed 2,500 linear feet of underground fiber between the water treatment plant and the South Pond pretreatment building to add it to the SCADA system.
- Installed a new PLC to integrate the chlorine dioxide system into the SCADA system for the entire treatment plant.
- Installed a backup generator.
- Shingled the water treatment building.

Water Treatment Building

- 2023 upgraded all mechanical and electrical controls for the treatment facility for the new generation of equipment installed in 2009 with the original construction of the facility and no longer supported by the manufacturer for replacement parts.
- 2023 upgraded SCADA system to a new version of the software.
- 2023 replaced membrane filters that were original to the water treatment plant construction in 2009.
- 2023 recoated steel membrane filter tanks during filter upgrade. Tanks were stripped to clean steel and coated.
- Installed new wiring between the raw water pump system and finished water high lift pump system to new equipment in the motor control center (MCC) in the treatment facility. The existing pumps were connected to the former treatment building MCC that was more than 30 years old and below flood elevation.
- Rebuilt raw water pump system with new piping and slide rails.

Water Storage Tanks

- 2023 Painting Project: There are two (2) 1-million-gallon storage tanks, one constructed in 1974 and the second in 2006. The 2006 storage tank will be cleaned and overcoated. The older storage tank will be stripped to bare steel and coated. During the painting project, improvements to the vent and overflow pipe will be completed.



-
- Upgraded the diffused air system at the storage tanks from compressed air to a blower pump system. The diffused air protects the storage tanks from freezing during winter conditions.

The most noteworthy deficiency in the JWD system is the gap between available supply and current and anticipated future demands. The JWD has been active at promoting water efficiency and establishing billing rates that encourage conservation in efforts to manage demand. Also, construction of a new treatment plant in 2010 with capacity of up to 500,000 gpd and the ability to treat raw water from South Pond were significant measures in managing supply. However, South Pond remains an unreliable source due to raw water quality and the treatment challenges and inefficiencies it creates.

One measure the JWD is currently taking is to reclaim approximately 6.05 million gallons of backwash water they waste from the treatment plant each year. Backwash water cannot be directed to the headworks of the treatment plant per the original design intent since attempts to do this during plant startup nearly damaged the membrane treatment units. Instead, backwash water is conveyed to two settling tanks for clarification before being discharged into Great Creek. The JWD is working with Harbor Controls for installation of a pumping system that will pump this clarified water to the plant headworks instead of discharging it. This represents a major component of non-account water that the JWD may be able to reclaim for use in the distribution system.

The JWD also plans to evaluate potential recharge of the North Pond watershed through modifying pumping at a stormwater pump station the Rhode Island Turnpike and Bridge Authority operates along Route 138. This pump station may also intercept groundwater that is then pumped out to the Bay, lowering groundwater in the watershed and potentially reducing the available water in the ponds and supply wells.

Lastly, JWD is currently evaluating the development of an existing well near the water treatment plant to supplement the raw water supply.

Given the limitations of supply and capacity of the existing system there is no ability to service the entire Town with water. The existing water system is limited in scope geographically to the village area within Jamestown and is not capable of extending beyond the water service area.



SECTION 3.0

WATER QUALITY PROTECTION COMPONENT

3.1 Source Water Assessment Plan

In April 2003, the University of Rhode Island Cooperative Extension, in cooperation with the Rhode Island Department of Health Source Water Assessment Program, completed a Source Water Assessment Plan (SWAP) and Wastewater Needs Analysis for the JWD. The SWAP was updated as part of the last WSSMP Update and has been updated again for this WSSMP Update. Refer to Volume II of this WSSMP. The findings of the 2022 SWAP Update determined that there was no change in the final risk rating for the Carr (North) Pond Reservoir and Watson (South) Pond Reservoir.

Figure 3.1 depicts the current land use within the source water protection area. Figure 3.2 depicts mapped sites with known contaminants based on data available from RIGIS, which shows that there are no such sites located within the source water protection areas.

3.2 Potential Impacts of Sea Level Rise

The JWD acknowledges the risks associated with the potential impacts of sea level rise on critical infrastructure, including within the water system. The treatment plant is within the 100-year floodplain and portions of the treatment plant site are located within the velocity zone. The JWD has begun evaluating and implementing modifications to minimize the potential risks associated with flooding at the treatment plant, such as elevating certain critical infrastructure components above the estimated flood elevation.



Figure 3.1 - SWAP Mapped Land Use Changes

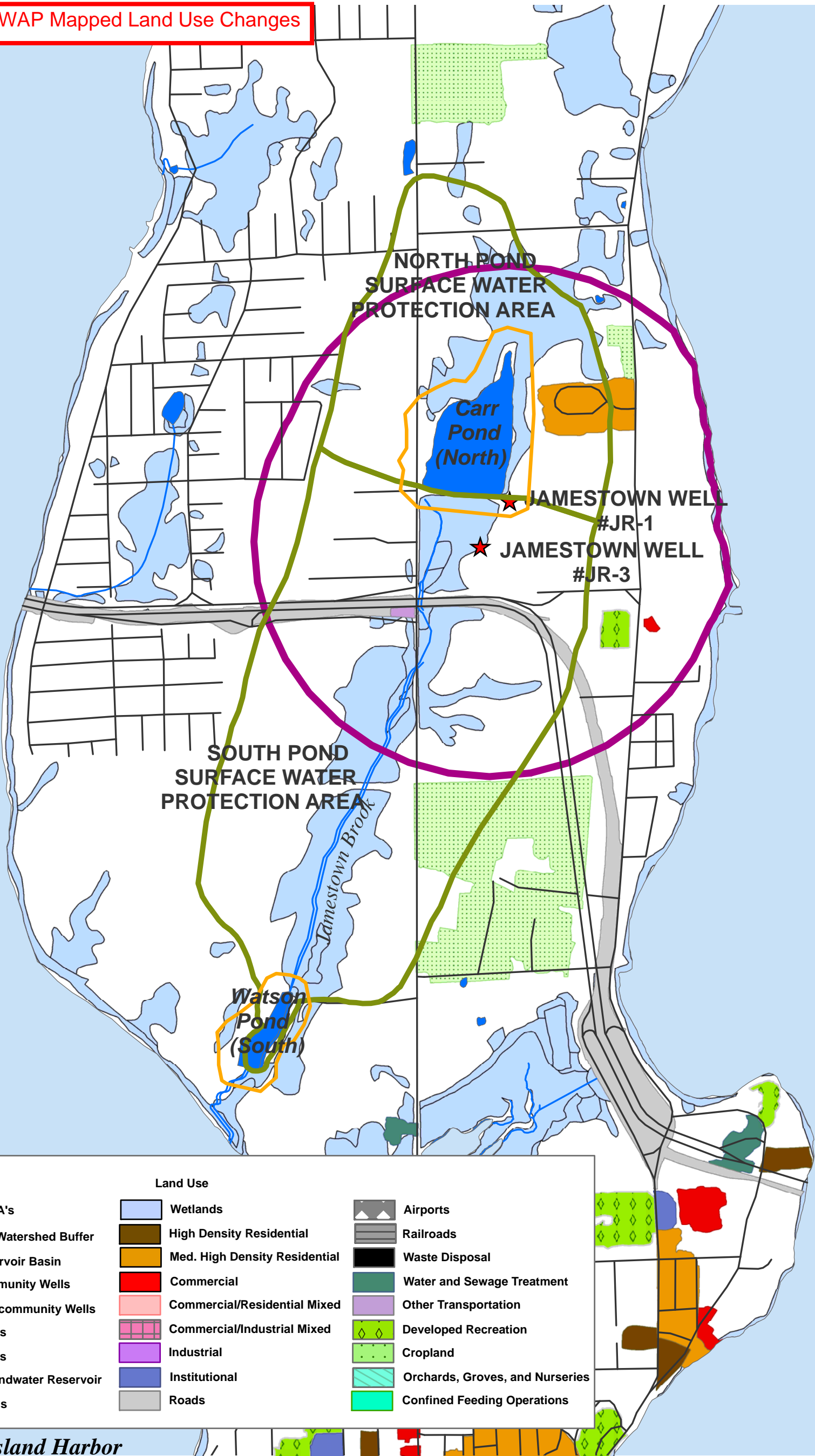

Legend

- | | | |
|-----------------------|-------------------------------|---------------------------------|
| WHPA's | Wetlands | Airports |
| 200' Watershed Buffer | High Density Residential | Railroads |
| Reservoir Basin | Med. High Density Residential | Waste Disposal |
| Community Wells | Commercial | Water and Sewage Treatment |
| Non-community Wells | Commercial/Residential Mixed | Other Transportation |
| Roads | Commercial/Industrial Mixed | Developed Recreation |
| Rivers | Industrial | Cropland |
| Groundwater Reservoir | Institutional | Orchards, Groves, and Nurseries |
| Ponds | Roads | Confined Feeding Operations |

Dutch Island Harbor



**Town of Jamestown (SWAP Assessment)
High-Intensity Land Use Changes Identified in
the Jamestown #JR-1 and #JR-3 WHPA's
and North and South Pond Reservoir Watersheds**



PARE CORPORATION
8 BLACKSTONE VALLEY PLACE
LINCOLN, RI 02865
401-334-4100

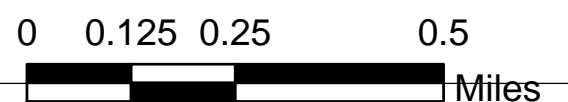
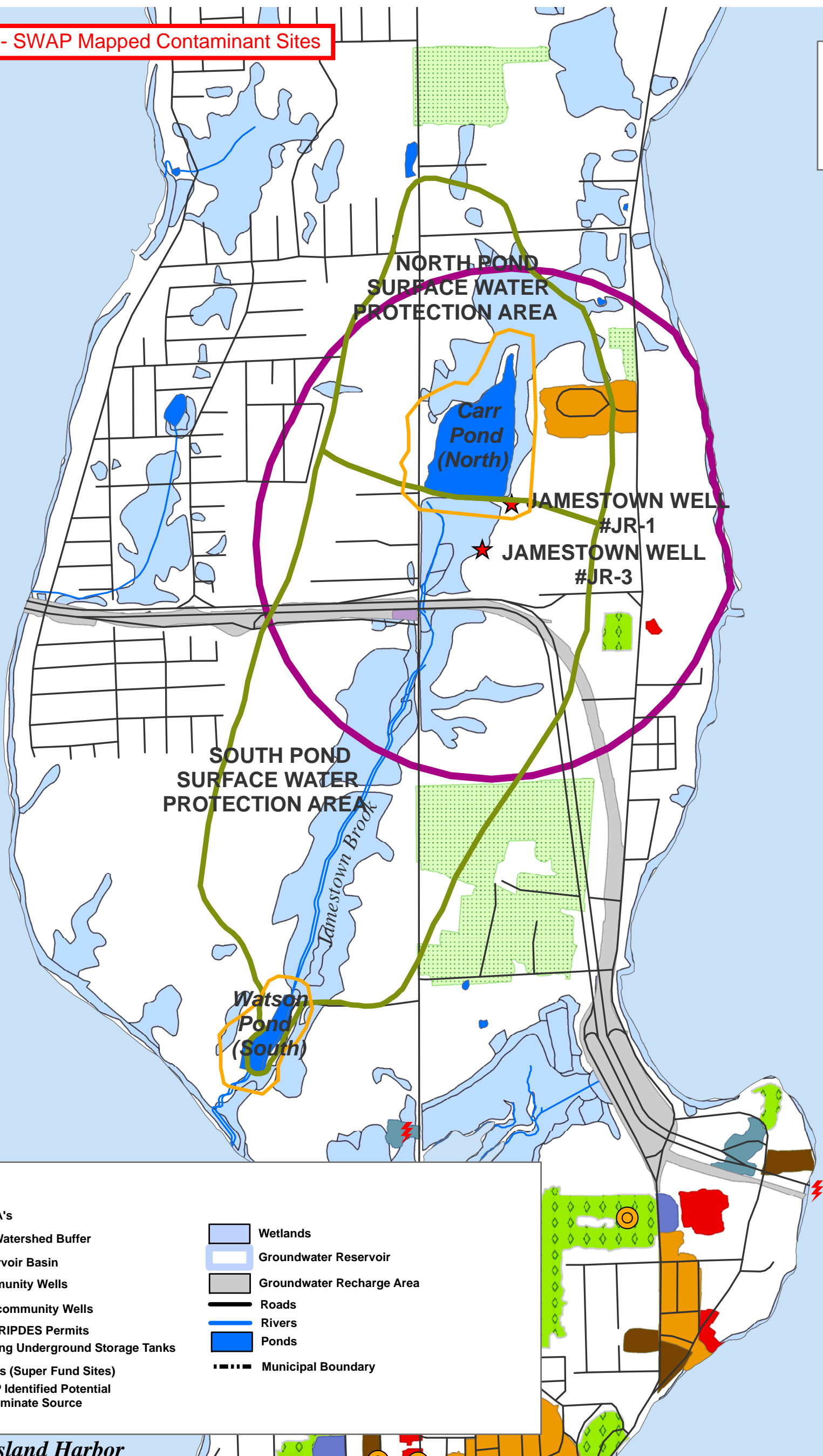
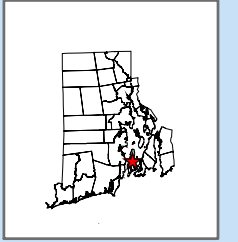

Figure 3.2 - SWAP Mapped Contaminant Sites



Legend

WHPA's	Wetlands
200' Watershed Buffer	Groundwater Reservoir
Reservoir Basin	Groundwater Recharge Area
Community Wells	Roads
Non-community Wells	Rivers
DEM RIPDES Permits	Ponds
Leaking Underground Storage Tanks	Municipal Boundary
Cerclis (Super Fund Sites)	
SWAP Identified Potential Contaminate Source	

Dutch Island Harbor



**Town of Jamestown (SWAP Assessment)
Potential Pollutant Sources Identified in
the Jamestown #JR-1 and #JR-3 WHPA's
and North and South Pond Reservoir Watersheds**



PARE CORPORATION
8 BLACKSTONE VALLEY PLACE
LINCOLN, RI 02865
401-334-4100

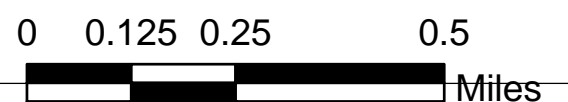

SECTION 4.0 ANTICIPATED FUTURE DEMANDS

The intent of this section is to project the future water demands expected of the JWD system for the 5-year and 20-year planning periods. To best project future water use several factors must be considered, including changes in population density, commercial water use and development, economic development, changes in service area, land use, water quality, and conservation measures.

4.1 Population and Economic Development

The RI Department of Administration, Division of Planning publishes population projections for each Rhode Island municipality at five-year intervals. These projections were made using 2010 US Census data, which estimated the population in Jamestown in 2022 to be 5,538. The projected population in Jamestown for the period of 2020 to 2040 is summarized in Table 4.1 below.

**Table 4.1
POPULATION PROJECTIONS (2020 – 2040)**

YEAR	POPULATION	ANNUAL % CHANGE
2020	5,484	--
2025	5,570	1.57%
2030	5,638	1.22%
2035	5,674	0.64%
2040	5,674	--

These projections show only modest population growth and are dramatically different than those previously developed by the RI Division of Planning based on past population trends and US Census data. The population trends projected for Jamestown are similar to population trends for many other communities in Rhode Island.

In 2024, the Town of Jamestown conducted an updated build-out analysis to reflect the current residential and commercial land use within the Town to forecast the potential new dwelling units and its impact on the existing water system (Appendix J). The potential new dwelling units were calculated using the current developable vacant and non-vacant lots, and ADUs on properties with lot sizes equal to or greater than 20,000 square-feet. This build-out analysis estimated an additional 1,208 residential and 156 commercial connections could potentially be connected to the Town water system over time. The full build-out of the 2024 projected growth is not anticipated to occur fully during the 5-year and 20-year planning periods. See discussion below in Section 4.3 and Table 4.4 for the breakdown of the 2024 municipal residential water system build-out analysis. It is important to note that no water main extensions or system expansion has been proposed in over 20 years, and none is anticipated at this time.

4.2 Projected Future Demands Based on Census Data

Future demand projections were made using the RI Statewide Planning population projections and the methodology described above. Previous versions of this WSSMP also projected demand for a full build-out scenario; however, current Census population projections represent only modest growth in Jamestown's population over time as compared to past projections that anticipated growth at a much faster rate. The Census population projected in Jamestown in 20 years (i.e., 2042)



is far less than the population at full build-out (based on the 2024 Build-out Analysis). The current Census projections predict that population will plateau in 2035. However, based on the 2024 Build-Out Analysis, the projected population growth far exceeds the RI Statewide Planning projected growth. See information below.

Table 4.2 contains the 5-year (2027) and 20-year (2042) future water use projections in the JWD water system based on 2022 US Census and RI Division of Statewide Planning data. It is assumed that all of the anticipated population growth in the Town of Jamestown will be within the water district, which is conservative.

**Table 4.2
CURRENT AND PROJECTED WATER CONSUMPTION RATES –
INCLUDES CENSUS POPULATION GROWTH ONLY ****

Year	Total Population in Jamestown	Population Projected in Service Area	Metered/Projected Water Usage			Total	Average Day Demand*
			Residential	Commercial**	Government		
2022	5,538	3,323	47.81 MG	4.21 MG	1.87 MG	53.89 MG	0.148 MGD
2027	5,597	3,382	48.66 MG	5.05 MG	1.87 MG	55.58 MG	0.152 MGD
2042	5,679	3,464	49.84 MG	7.58 MG	1.87 MG	59.29 MG	0.162 MGD

* Based on consumption alone (i.e. non-account water not included)

** Commercial projections based on 2024 Build-Out Analysis Data

Residential water use for the 5-year period was projected based on a service area population of 3,382 people and an average per capita residential water use of 39.4 gpcd equivalent to the average per capita residential water use for 2022. Only modest population growth based on Census data is expected over this timeframe and residential water use is anticipated to remain relatively consistent. Similarly, residential water use for the 20-year planning period was projected based on a service area population of 3,464 and 39.4 gpcd. This assumes that efficient residential water use continues to be a priority in Jamestown.

Water use by the government sectors in Jamestown has declined over time, and relatively little governmental development is expected in the JWD service area or in Jamestown as a whole. Governmental water usage for the 5-year and 20-year planning periods were projected to be equivalent to the fiscal year 2022 governmental usage of 1.87 MG. As part of the 2024 build-out analysis, the current commercial vacant land use for new development is almost at capacity and not much commercial growth is expected from vacant land use. There is potential commercial growth for existing commercial non-vacant lots that could be sub-divided into new lots that would increase system demand overtime. The commercial zone growth from non-vacant commercial lots is expected to be for residential usage with two (2) condos per lot. However, this growth would not be expected to occur all at once. As a result, commercial water usage for the 5-year and 20-year planning periods were projected to increase by five (5) new commercial connections each year. In 2042, the potential commercial growth would be close to capacity based on the development of



non-vacant lots. Commercial non-vacant lot build-out development would be at capacity in 2053 if five (5) new commercial connections are established each year from 2022.

The JWD has traditionally used a maximum day to average day peaking factor of 2.0 to estimate maximum day demand (MDD) in the system. Table 4.3 shows the current ADD and MDD as well as projections for the 5-year and 20-year planning periods, based on consumption.

Table 4.3
CURRENT AND PROJECTED AVERAGE DAY & MAXIMUM DAILY DEMANDS ON
CENSUS POPULATION GROWTH ONLY

YEAR	AVERAGE DAY DEMAND*	MAXIMUM DAY DEMAND**
2022	0.148 MGD	0.296 MGD
2027	0.152 MGD	0.304 MGD
2042	0.162 MGD	0.324 MGD

* Based on consumption alone (i.e., non-account water excluded)

** Estimated using MDD to ADD ratio of 2.0

Projected estimates for water produced have been made assuming 11.88% non-account water, consistent with State goals. Therefore, the ADD and MDD for 2022 based on water production are estimated to be 0.168 MGD and 0.336 MGD, respectively. For the 5-year planning period, the ADD and MDD are estimated to be 0.171 MGD and 0.342 MGD, respectively. Similarly, the ADD and MDD are estimated to be 0.175 MGD and 0.350 MGD for the 20-year planning period. JWD is currently seeking other alternatives for additional source water production. See Worksheet Nos. 12 and 15.

It is noted that non-account water currently is below 15% (11.88%) and has met the State’s goal of 15% . This is mostly attributed to the process water requirements for the operation of the water treatment plants. This estimate is presented on Worksheet No. 11. Worksheet No. 11 underscores the importance of JWD obtaining a better understanding of, and altogether lowering, non-account water in the system. One significant step toward this goal is reclaiming the majority of backwash water that currently is discharged to Great Creek, as discussed in Section 2.10 of this WSSMP.

4.3 Projected Future Demands Based on 2024 Build-Out Analysis

In January 2023, Rhode Island General Law 45-24, as amended and titled, “An Act Relating to Towns and Cities – Zoning Ordinances”, allows the owner to build an accessory dwelling unit (ADU) on any lot with a total area of 20,000 square feet or more for which the primary use is residential and where the proposed ADU is located within the existing footprint of the primary structure or existing secondary attached or detached structure and does not expand the footprint of the structure. The legislation was passed to address the projected shortage of housing by making it easier to build ADUs.

In 2024, the Town of Jamestown conducted an updated build-out analysis to reflect the current residential and commercial land use within the Town to forecast the potential new dwelling units and its impact on the existing water system. The potential new dwelling units were calculated using the current residential and commercial minimum lot zoning requirements on the developable vacant and non-vacant lots, and ADUs on residential vacant and non-vacant properties with lot sizes equal to or greater than 20,000 square-feet.



Table 4.4 contains the 5-year (2027) and 20-year (2042) future water use projections in the JWD water system estimating residential and commercial population growth from potential current developable vacant and non-vacant lots, and ADUs. For this analysis, the governmental water usage remained the same as in Table 4.2 since it's not anticipated that there will be much growth in these areas in the coming years. The commercial water projections as explained above and noted in Table 4.2 will be used in Table 4.4.

ADUs in Table 4.4 are estimated based on 12 new dwelling units constructed each year with half of the dwelling units being one-bedroom and the other half of the dwelling units being two-bedroom. Each year estimates that the Jamestown population will grow by 36 people (two people per bedroom) with the construction of ADUs alone. Table 4.4 also estimates that each year 4.0 vacant lots and 5.5 sub-dividable lots are used for new home construction with includes condominiums. Each year estimates that the Jamestown population will grow by 22 people (2.34 persons per household) with the development of vacant and non-vacant developable sub-dividable properties. In total, each year there is an estimated population growth of 58 people in Jamestown. This information is also presented on Worksheet No. 12.

Table 4.4
CURRENT AND PROJECTED WATER CONSUMPTION RATES
INCLUDES POPULATION GROWTH BASED ON BUILD-OUT ANALYSIS DATA**

Year	Total Population in Jamestown** *	Population Projected in Service Area With 2024 Build-Out Analysis	Metered/Projected Water Usage				Average Day Demand*
			Residential	Commercial	Government	Total	
2022	5,538	3,323	47.81 MG	4.21 MG	1.87 MG	53.89 MG	0.148 MGD
2027	6,023	3,614	51.99 MG	5.05 MG	1.87 MG	58.77 MG	0.161 MGD
2042	7,479	4,488	64.57 MG	7.58 MG	1.87 MG	74.02 MG	0.203 MGD

* Based on consumption alone (i.e., non-account water not included) with residential population increase from 2024 Build-Out Analysis)

** Based on residential and commercial projections from 2024 Build-Out Analysis Data

*** Assumed growth at the same rate as the water district



Table 4.5
CURRENT AND PROJECTED AVERAGE DAY & MAXIMUM DAILY DEMANDS
BASED ON
BUILD-OUT ANALYSIS DATA

YEAR	AVERAGE DAY DEMAND*	MAXIMUM DAY DEMAND**
2022	0.148 MGD	0.296 MGD
2027	0.161 MGD	0.322 MGD
2042	0.203 MGD	0.406 MGD

* Based on consumption alone (i.e., non-account water excluded)

** Estimated using MDD to ADD ratio of 2.0

4.4 Projected Future Demand Based on Bedroom Data Only

JWD also compared the current bedroom count in the water district to get a sense of what the future water demand would be if every bedroom currently in the water district was occupied. Currently, there are 4,271 total bedrooms in the water district and with two people per bedroom at 39.4 gpcd (estimated above), the future water demand could be as high as 337,000 gpd. This value represents the MDD that is currently experienced within the system at times and provides the most conservative worst-case scenario. The MDD is reached normally at the height of the summer season when there are a lot of seasonal visitors to the Town.

4.5 Category & Subcategory and Major Users Future Demand

Future residential and commercial water demands are summarized on Worksheet No. 12 and in Table 4.4. There are no major users in the system, nor are any current users expected to increase demand to rates that would qualify them as a major user (i.e., demands in excess of 3 million gallons annually). The JWD is not aware of any potential major user currently in planning.

4.6 Legal Obligations to Provide Water

The JWD does not have any wholesale customers, major users, or any other legal obligations to provide water.

4.7 Service Area Extension

4.7.1 Urban Water District

Under the Urban and Rural Water District Regulations adopted in 1986, the Town has specific guidelines for new connections to the water system. Service connections for use other than one or two-family homes require approval of the Board of Water and Sewer Commissioners. Applicants must show to the satisfaction of the Board that the request for service:

- 1) is consistent with the Comprehensive Community Plan;
- 2) will not impair available resources of the urban water district;
- 3) will not reduce the level of fire protection; and
- 4) will not reduce the quality or quantity of water provided to existing users.



Property owners whose land is within the district or which has frontage on a district boundary road may request a water service connection. Because of the relatively small supply capacity of the system, no expansion of the urban water district is planned or anticipated at this time.

4.7.2 *Jamestown Shores Neighborhood*

From time to time, the issue of water service to the Jamestown Shores area is raised. This area in the northern half of the island houses 40% of the Town's overall population. There is currently no public water service available in the area.

The Shores area was subdivided in the 1940s into very small lots. Most lots are less than a quarter acre. Each home must have a well and onsite sewage disposal system on the property. This factor, coupled with poor soil conditions, creates the potential for groundwater contamination.

If water quality problems become evident in Jamestown Shores, measures may be needed to provide potable water to the area. This scenario would exact a severe financial and service burden on the Water Department. New transmission lines, pump stations, and possibly other system improvements would be required. There are no plans for serving this area now or in the immediate future, but it is doubtful whether sufficient raw water could be found on the island to meet this demand should it become necessary.

It is therefore imperative that the Town of Jamestown makes every reasonable effort to ensure that water quality in the Jamestown Shores area is maintained. Steps that the Town has taken and should continue in an effort to minimize health risks associated with this area include:



- Monitoring RIDEM's granting of OWTS permits in the area;
- Require maintenance of existing septic systems;
- Create a soils overlay district and have limitations on impervious surface coverage based on soils suitability;
- Strictly enforce RIDEM regulations on OWTS setbacks from wetlands;
- Encourage RIDEM to consider alternative OWTS technology where appropriate.
- Purchase of lots for preservation; and
- RIDEM limits bedrooms based on OWTS capacity based on soils suitability.

4.7.3 *Consolidate the Two Current Water Districts into One Water District*

Based on the current configuration and distribution network of the water system, the prior distinction of an urban and rural district is no longer useful or meaningful. Moving forward, the Jamestown water supply and distribution system should be classified as the Jamestown Water District. This classification better represents the factual configuration and distribution network of the water system. In addition, this classification clearly defines that the public water supply network is confined to a limited geographic area within the Town's municipal boundaries. Jamestown's current water supply and production, as evidenced in this Plan, is a limited resource which cannot safely or adequately supply an expansion of the current water supply network beyond the current water supply and distribution network as illustrated and bounded in the Jamestown Water District map, as shown on Figure 4.1. The Commission will consolidate the Urban and Rural water districts and replace them with one water district. The district boundaries shall be limited to the northern boundary of the current district and extend south to the incorporate the extent of the areas serviced by the current districts. There will be no provisions for extensions outside of this service area based upon limited capacity of the resources and the anticipated future demand determined by the build-out analysis completed in 2024. The Commission intends to adopt one uniform set of rules and regulations to govern all operations of the current service area.



Legend

-  Jamestown
-  Proposed Water District

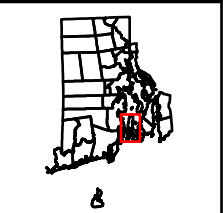
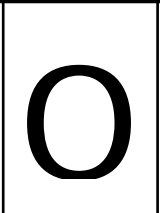
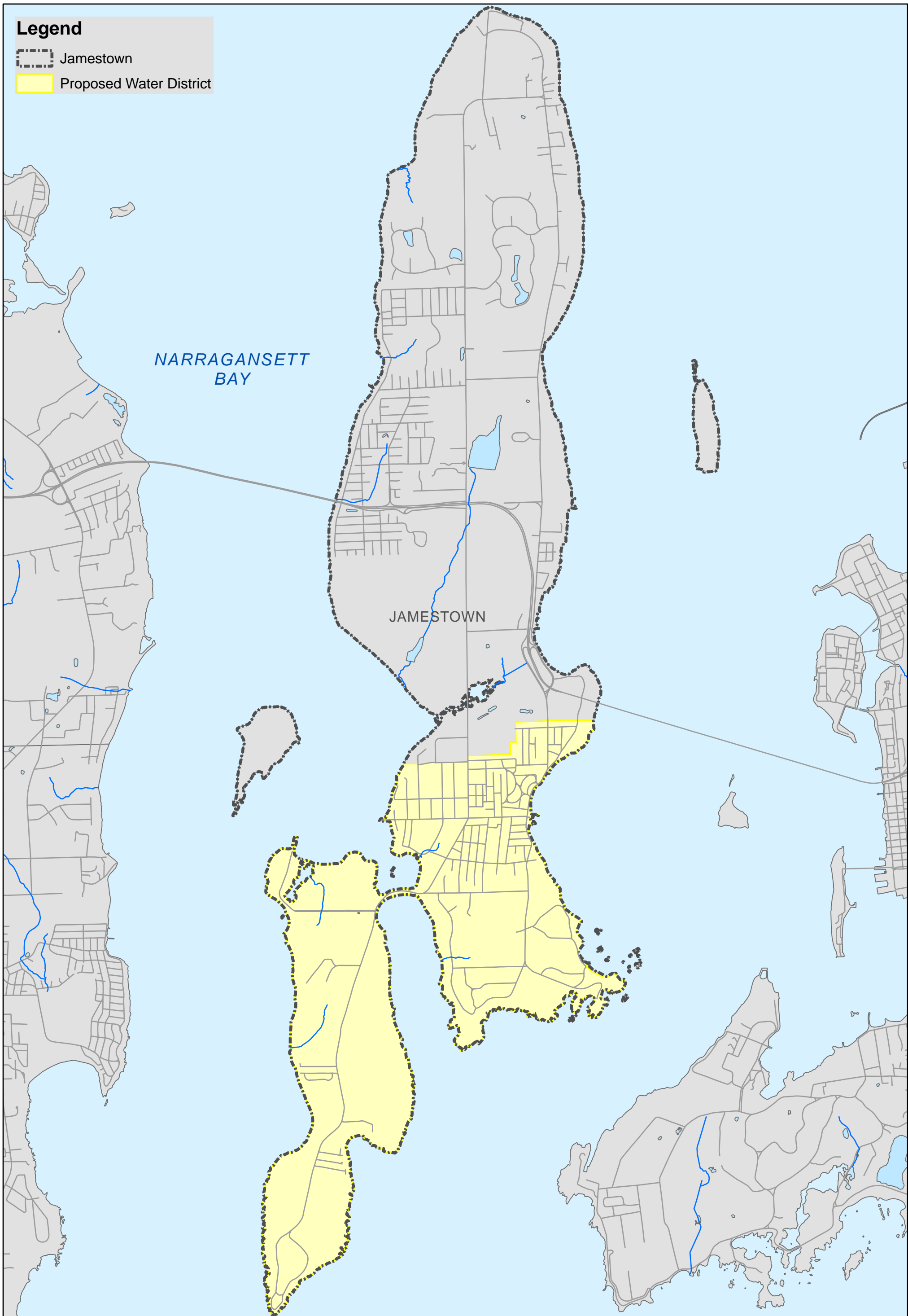

**JAMESTOWN WATER DISTRICT
(PROPOSED)**

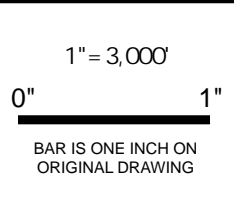

PROJECT NO.:	17103.04
DATE:	APRIL 2024
SCALE:	AS NOTED
DRAWN BY:	SJP
APPROVED BY:	JA

FIGURE 4.1

SECTION 5.0 AVAILABLE WATER

5.1 General

North Pond is the primary water supply for the Jamestown system. The JWD supplements the reservoir with water withdrawn from their supply well, JR-1, during peak demand times of year. Well withdrawals typically make up a very small amount of the water withdrawn from the JWD's sources.

Analysis of the safe yield of the North Pond Reservoir system was conducted previously by staff of the Rhode Island Department of Environmental Management, Division of Water Supply Management. The purpose of the study was to determine the ability of the existing system to meet the water supply needs of the existing customer base. The full report was provided in the last WSSMP, while this chapter presents the major findings of the study. Also presented are the findings of a more recent study, completed in 2000 by Fay, Spofford and Thorndike, Inc. (FS&T).

In times of drought, the JWD has also utilized South Pond for its water supply. A study of the safe yield of the watershed was conducted by Richard Hazen in 1983. This report will be referred to for supporting data on the probable safe yield of South Pond, though the reservoir has not been used for some time.

5.2 Physical Characteristics of the Reservoirs

Jamestown's reservoirs were constructed in the 19th century by the creation of earth dams in two natural drainage swales. The spillways have been modernized to concrete structures permitting outflow above a certain water level. There is no provision for flashboards at either spillway. Elevation of North Pond, when full is 37 feet above mean sea level, 27 feet above South Pond.

Both reservoirs are shallow, and as such are subject to high rates of evaporation during the hottest months. South Pond, being of small capacity with a fairly large drainage area, is very responsive to rainfall, especially when the ground is saturated. Public Works officials have observed the water level in South Pond rise a foot overnight. Because of the physical and water quality limitations of South Pond, it is not considered a reliable source of supply but remains an active source that can potentially be used in the future should some of its water quality limitations be suitably addressed.

5.3 Safe Yield of Surface Waters

5.3.1 *FS&T Safe Yield Analysis, October 2000*

FS&T completed a safe yield study of North and South Ponds in October 2000 on behalf of the JWD. The Safe Yield Analysis Report (text only) is included in Appendix D. This represents the most recent safe yield analysis performed on the JWD's supply sources.

FS&T created a computer model to simulate the Town's water supply system and compute the safe yield. The model incorporated historic hydrologic and hydraulic factors (i.e., precipitation, direct runoff, evaporation, demand withdrawal rates) as well as current operational factors in its mass balance approach. The results of this analysis are presented in Table 5.1. A second safe yield analysis was then conducted whereby the transfer of water from South Pond to North Pond was simulated. These results are presented in Table 5.2.



Table 5.1
SAFE YIELD (gpd)

Average Surface Water Inflow Factor	North Pond	South Pond	Total
0.40	175,000	86,000	261,000
0.45	194,000*	89,000	283,000
0.50	213,000	92,000	305,000

* Currently, JWD is using the safe yield for North Pond of 185,000 gpd as a result of the RIDEM analysis and Drought of Record (See below). South Pond is not available during dry periods and is only used to transfer water to North Pond when water is flowing over the South Pond dam.

Table 5.2
SAFE YIELD WITH TRANSFER PUMPING (gpd)

Average Surface Water Inflow Factor	North Pond	South Pond	Total
0.40	304,000	80,000	384,000
0.45	321,000	83,000	404,000
0.50	333,000	55,000	421,000

A transfer pumping system between South Pond and North Pond is in place but is not typically used due to the water quality issues in South Pond. Also, the transfer pumping system can only pump water from South Pond to North Pond when there is water flowing over the South Pond dam.

5.3.2 Previous Analyses

RIDEM chose a method of computer mass balance of reservoir inflows and outflows using the U.S. Army Corps of Engineers Hydrologic Engineering Center program HEC-5: Simulation of Flood Control and Conservation Systems.

The Hazen study used stream flow records of mainland rivers. Additionally, the study used storage yield curves recorded in NEWWA reports from 1969. Studies of the 27 square-mile Abbott Run watershed and the 93 square-mile Scituate watershed during the record-breaking drought of the mid 1960s were used to determine the expected yield of a reservoir in the region. The NEWWA procedure takes into account the drainage area; the percentage of drainage area covered by the reservoir; the rainfall and probable loss by evaporation; the stream flow; and the storage required to assure the desired supply. Data are computed on the basis of drainage areas, with safe yield and storage required stated per square-mile.

North Pond

Applying the HEC-5 methodology, the following are the results of the safe yield analysis for different drought scenarios:



**Table 5.3
NORTH POND SAFE YIELD**

Drought Analysis	Safe Yield (GPD)
1% change of occurrence (100% reliability)	175,000
5% change of occurrence (95% reliability)	210,000
Drought of Record (99% reliability)	185,000

South Pond

Although South Pond is a small reservoir, it receives runoff from 70 percent of the watershed, or 0.7 square-miles. Total runoff is 700,000 gpd, but the characteristics of the drainage area are significantly different from the North Pond drainage area. A vast wetland encompasses much of the watershed above South Pond. This increases evaporation and transpiration and reduces the quantity of runoff, especially during dry weather.

South Pond was drawn daily for five months in early 1981. Pumping averaged 180,000 gpd, with a maximum one-day yield of 364,000 gallons. Hazen’s estimate of the safe yield of the reservoir is as follows:

**Table 5.4
SOUTH POND SAFE YIELD**

Drought Analysis	Safe Yield (GPD)
2% change of occurrence (98% reliability)	100,000

Like the FS&T Evaluation, the results of this study suggest that partial use of South Pond would substantially increase available water to the system.

Because South Pond is served by more than two thirds of the drainage area of the watershed, its storage capacity is the primary limiting factor in its utility to the water supply. The other deficiency of South Pond is water quality. Below North Pond, runoff passes slowly through a large wetland on the way to South Pond. This "percolating" process causes the water in South Pond to have high quantities of organic matter, iron, acid, and other contaminants. This results in discoloration and unpleasant tastes and odors.

Drought Duration

The drought of the 1960s is generally considered the drought of record in this region. However, at the time of the drought, the population of Jamestown was around 2,500, half of the current population. No records exist as to the extent of the drought in Jamestown, but anecdotal information suggests that the Town's water system did not experience an inability to provide sufficient water to customers.

During the summer of 1993, a short-term drought occurred. From late-July through September, Jamestown received very little rainfall. As the summer season progressed, evaporation combined with diminished inflow and high demand to create a crisis situation for the water supply system. South Pond, normally reserved for supplemental supply, was already at the bottom of the reserve storage zone though no water had been drawn from it. The Town instituted an outdoor watering ban in August, and conservation was greatly encouraged.



Efforts to reduce water consumption were not sufficient to stabilize the level of the reservoirs. By late summer North Pond held only a 20-day supply of water. The National Guard was notified, and began delivering water by truck from North Kingstown. This practice continued until November 15 of that year.

When winter rains began to recharge South Pond, it was used to supply the water system, allowing North Pond to recharge without use. It was found that when water is drawn from South Pond, the rate of flow through the upstream wetland increases. This unfortunately does not result in improved water quality.

In the final analysis, the National Guard delivered 7.5 million gallons to the Jamestown water supply. It was estimated at the end of the deliveries that the North Pond volume was 6.7 million gallons. Jamestown would almost certainly have run out of water had not the National Guard helped supplement the supply.

The Town has prepared a plan to avoid having a situation like the 1993 water deficiency in the future. The plan is described in the augmentation study section as well as in Section 10 – Drought Management of this WSSMP.

Water Withdrawals

There are no withdrawals from Jamestown Brook.

5.4 Limitations to Water Use

The new water treatment plant has a design capacity of 0.5 MGD, more than the safe yield of the supply sources and above current and future estimates of the MDD. The only limitation to drawing water is the water quality of South Pond. Even when the reservoir is full, water quality at South Pond is much lower than North Pond. While the new treatment plant was designed to treat water from South Pond, sludge generation when using raw water from South Pond makes the treatment plant inefficient. Therefore, supply from South Pond is not typically used.

5.5 Available Water/Demand Comparisons

Although the two reservoirs appear to have a combined safe daily yield of 283,000 gallons, the actual available water is less due to the poor water quality of South Pond, as noted above. In the past, North Pond has been used almost exclusively for supply, providing the Town with a safe daily yield of 185,000 gallons (based on the RIDEM analysis and the Drought of Record). Also, it is doubtful whether South Pond could truly provide 100,000 gpd, due to the water quality problems described above. The ADD exceeds the safe yield of North Pond during the warmer months each year, and the JWD supplements supply with withdrawals from Well JR-1 (~50,000 gpd) in periods of higher water use. Based on plant data, flow from JR-1 varies between the range of 24,000 and 48,000 gallons per day. Flow from JR-1 varies throughout the year between this range and is at maximum pumping capacity during summer months. The JWD has implemented a number of water conservation strategies and continue to impose outdoor water use restrictions in an attempt to control water use peaks during the summer months. The total daily yield from North Pond and Well JR-1 is 233,000 gallons.



5.6 Alternative Supply

The JWD maintains alternative supply sources in addition to North Pond and the two active supply wells, JR-1 and JR-3. While South Pond is considered an active supply source and is maintained as such, it effectively acts as an alternate surface water supply as withdrawals are infrequent due to raw water quality.

It was the JWD's intent with construction of the new treatment plant in 2011 to increase treatment capacity to 500,000 gpd while also having the capability to treat water from South Pond. In practice; however, the treatment process is inefficient and a high volume of sludge is generated when raw water from South Pond is used, making withdrawals from South Pond impractical.

Over the years, the JWD explored development of additional supply wells around wells JR-1 and JR-3. However, these other wells are currently not being used as supply due to concerns over groundwater depletion.

The JWD has a non-permanent emergency interconnection with North Kingstown, consisting of truck-mounted flexible piping that can be connected to hydrants on either side of the Jamestown Verrazano Bridge. This interconnection is not intended for permanent use, and development of a permanent interconnection is not immediately feasible and would be extremely costly due to Jamestown's isolated nature as an island in Narragansett Bay, over a mile from the nearest mainland.

5.7 Supply Augmentation Study

Since 1993 the Town has investigated various alternatives to source augmentation to meet the ever-increasing demand requirement of drinking water. The following summarizes the actions taken in an effort to augment supply.

5.7.1 Water Supply Committee Report (1995)

In response to the drought of 1993, the Town established a Water Supply Committee. The committee was comprised of a variety of professionals with expertise in drinking water issues. Over a two-year period, the committee developed and evaluated a number of alternatives to increase the supply of public water. The committee completed its report in 1995.

A copy of the Water Supply Committee report was provided in the previous WSSMP. Below is a brief description of the primary alternatives considered by the committee, as presented in this report. The committee was only charged with evaluating supply augmentation. Water conservation has been considered separately by the Conservation Commission and JWD staff.

1. *Expand North Reservoir* – This alternative included diversion of Carr Creek and improvements to the impoundment dam. Carr Creek watershed has an area of 0.11 square-miles, which could yield over 100,000 gpd. Also, it was estimated that raising the spillway and dam at North Pond by 12 inches would result in an increase in storage capacity of 8 MG. This volume represented a 35-day supply of water, based on 1992 consumption. It would represent a 40-day supply based on current ADD.

Both the Carr Creek diversion and dam improvements involve significant permitting and engineering studies. The committee recommended no action on this alternative at that time, and this alternative has not been revisited since.



-
2. *Development of South Pond* – South Pond could be utilized if water quality were improved sufficiently to make the water treatable. Methods of reducing the effects of organic material in the watershed were discussed, but this possibility was dismissed as impractical and requiring extensive further study.

Initial results indicate the same portion of South Pond water may be returned to North Pond through transfer pumping or mixed at the treatment plant, but this alternative required further evaluation. Since then, the new treatment plant was designed to treat water from South Pond but the increased sludge generation would make treatment too inefficient for long term use.

3. *Bedrock Drilling* – This approach involves drilling a series of wells to tap water trapped in bedrock fissures. Significant background study has been done to determine the most effective well locations. The water would be pumped directly into the distribution system if quality is high enough, or it could be pumped to the treatment plant.

The JWD has done extensive well exploration over the years. Well JR-3 is a result of these efforts and has been in service since 2000.

4. *Water Conservation* – Developing methods of reducing per capita consumption were recommended as part of the report. The Conservation Commission has recommended specific steps for water conservation. These affect residential and commercial consumers, as well as treatment plant operations.

Among the most significant recommendations in the report are: (1) an education program to raise public awareness on methods of water conservation, and (2) “change-out” and retrofit programs to encourage/require users to utilize water-conserving fixtures, toilets, and washing machines. The results of these programs are discussed elsewhere in this WSSMP.

Results

The Town opted to pursue Alternatives #3 and #4, which were met with success. Well JR-1 has been in service since 2000. Estimated yields from the wells JR-1 and JR-3 are 50,000 gpd, each. They are only used at times of year with high demand. Water conservation measures have also been proven successful and the JWD will continue to pursue water conservation in the system. For instance, the ADD presented in the 1993 report was 248,000 gpd and was a similar rate in the 2000 Safe Yield Analysis performed by FS&T, referenced earlier. Future ADD estimates were projected to increase, but they have decreased and the ADD currently averages 200,000 gpd for a typical year. The JWD has realized a lot of success through water conservation practices.

5.7.2 Water Treatment Feasibility Study – 1999

In September 1998, the Town of Jamestown contracted Fay, Spofford & Thorndike, Inc. to evaluate alternative sources of water supply and the feasibility of associated water treatment requirements. A Water Treatment Feasibility Study was prepared in April 1999. The Executive Summary from the Report was provided in the previous WSSMP. Below is a brief description of the alternatives that were considered in the report.

The report concluded that North Pond is not able to meet the ADD based on its estimated safe yield, and recommended that the Town explore one of two tracks for increasing supply. One of the options presented in this report was to



“establish a permanent connection with North Kingstown at an estimated life cycle cost of about \$3.2 million pending discussions with North Kingstown officials and a more detailed cost evaluation. This has the advantages of providing adequate water supply and being more reliable in terms of water quality. The major disadvantages are cost and the Town becomes dependent upon an outside community for its water supply.”

The Town has since developed a non-permanent emergency interconnection (6-inch flexible water line) between hydrants with the Town of North Kingstown and the Town of Jamestown, but a permanent connection has not been implemented as JWD is currently waiting for approval from RIDOH.

The second recommended track was to develop additional supply in Jamestown. Since 1995 the Town had done extensive well exploration and development. These efforts resulted in installation of Well JR-3 with an estimated safe yield of 50,000 gpd, like that of Well JR-1 though both wells are never used at the same time.

Utilizing Narragansett Bay as a water supply source had also been reviewed. High-pressure reverse Osmosis (RO) is the membrane-separation technique typically utilized to reduce the total dissolved solids (TDS) in the seawater from 34,000 mg/l to less than 500 mg/l for drinking water. This was a very costly option, estimated at close to \$6 million for construction of a desalination plant. Costs associated with desalination have increased since completion of this report and this alternative has not been seriously explored in recent years.

5.7.3 Limnological Baseline Study

In 1999, the Town retained Ecosystem Consulting Service, Inc. to conduct a limnological baseline study of the surface water sources based on recommendations from FS&T’s 1998 report summarized above. The intent of this study was to quantify the quality of water from the two reservoirs, identify reservoir management techniques, and investigate ways to increase available water supply for the Town. The end result was to assist in identifying cost effective, reasonable approaches to increasing water availability for the Town.

On December 16, 1999, FS&T issued a final/supplemental limnological baseline study for the North and South Ponds in addition to the above. This report identified specific alternatives which could be implemented to increase the overall yield from the surface water supplies while maintaining a reasonable water quality, given the raw water quality limitations of South Pond.

Both reports were provided in the previous WSSMP. Several recommendations for increasing the available water supply were presented, which are summarized as follows:

- Increase Safe Yield from North Pond
 - Intercepting and treating water from the South Pond watershed adjacent to the North Pond watershed north of Route 138 and east of wells JR1 and JR3, and diverting this water to North Pond.
 - Increasing the North Pond Reservoir level by 10-14 inches by the addition of flashboards during early summer.
- Improve Water Quality from North Pond



-
- By the addition of stormwater detention basins to treat water entering North Pond from the watershed area west of North Main Street. The DPQ was already developed design plans for the installation of these basins to address this issue.
 - The addition of a hypolimnetic aeration and depth selective supply withdrawal system.
- Improve South Pond Water Quality
- Correcting the “leakage-overflow” to the west from South Pond.
 - Increasing the storage volume in South Pond through a shallow reservoir expansion to the west from the dam.
 - Installing a hydrologic discharge control assembly at the South Pond spillway.
 - Installing a depth-selective supply withdrawal structure at South Pond.

The total cost of these recommendations was estimated at \$95,000. It was also recommended that a safe yield study of North and South Ponds be conducted to verify the proper transfer rate between the two ponds and to determine the impact of increasing the North Pond reservoir level. This was conducted in 2000 and was discussed earlier in this section.



SECTION 6.0 SUPPLY MANAGEMENT

6.1 Water Quality Protection

The Town of Jamestown recognizes the critical nature of protecting the public water supply. Because Conanicut Island lacks a municipal quality aquifer, protecting the surface reservoirs is very important. The Town has taken a number of measures to ensure long-term protection of the reservoirs and watershed.

The remainder of this section contains measures undertaken by the Town of Jamestown to ensure the protection of Jamestown Brook Watershed. It is intended, that upon completion of this section, the reader will understand the level of commitment that Jamestown has demonstrated towards the protection of its most valuable resource.

Zoning

There are no industrial uses within the public supply watershed. All 760 acres of the Watershed are in the RR-200 zoning district with a minimum lot requirement of 200,000 square-feet (4.6 acres), however, the land is predominantly open space. As such, there are no known point sources of pollution within the watershed.

In order to further protect the watershed, the Zoning Ordinance prohibits location of any onsite wastewater treatment system (OWTS) within 150 feet of a bog, floodplain, pond, marsh, or swamp.

The Zoning Ordinance also contains a lot merger provision for identical ownership of small parcels.

Site Plan Review

Over 85% of the watershed has been permanently protected from development. Property that remains in private ownership has little potential for development. A site plan review process is used to ensure that future development within the watershed does not adversely affect water quality. A development plan is required for any construction in the district that is zoned RR-200. The plan must include a topographic map, a soils map, and a discussion of water quality impacts. Topics covered should be as follows:

1. Erosion control during construction;
2. Disposal of storm water runoff; release rates, drainage system, detention/ retention basins;
3. Sewage disposal methods and impacts on the environment;
4. Area of impervious surface, measures for groundwater infiltration; and
5. Disclosure of any toxic substance to be stored on site.

The standards for review of the development plan are as follows:

1. Rhode Island Erosion and Sediment Control Handbook
2. Area of disturbance must be at least 300' from reservoir or any tributary
3. Minimize impervious surface
4. Permanent vegetation cover in unpaved areas
5. Construction must minimize area of disturbance and time of exposure
6. Detention and retention basins for no net increase in runoff



Underground Storage Tanks

New underground storage tanks are prohibited in all districts.

Subdivision Regulations

Any subdivision of land in Jamestown must include a soil erosion control plan that must conform to Eastern RI Soil Conservation District.

Wastewater Management

The Town of Jamestown passed an ordinance in 2001 geared toward improving maintenance and inspections of OWTS on the Island. The program consists of routine inspections, issuing maintenance reminders, a web-based database, system siting and installation requirements, and the designation of a High Groundwater Table District. The Town performed an initial round of inspections in 2003 and began a routine inspection program in 2006. Systems are inspected every three or five years based on system size and the results recorded on the web-based database. The Town can authorize pump-out of a system at the property owner's expense if they deem the system to be at risk of impending failure. Several dozen systems have been repaired or replaced as a result of this inspection program.

Conanicut Island Land Trust (CILT)

CILT remains active in identifying priority properties and wetland areas and taking appropriate protection measures. This includes properties within the watershed of North and South Ponds.

In addition to the land trust, the Town of Jamestown will continue an aggressive acquisition of fee simple and development rights to all properties located within the Jamestown Brook watershed. This is in accordance with the Jamestown Comprehensive Community Plan.

Copper Sulfate Application

Because of the relatively shallow basin of both reservoirs, periodic applications of copper sulfate are made to control algae. The Water Department monitors water quality testing and maintains a copper reading of 1 ppm in North Pond. In most years, this requires 3 to 5 treatments per summer. Treatments are made by hand from a small boat at the rate of 300 lbs. per month from May through August.

South Pond is rarely treated because it is seldom used as a water supply source. Also, the turnover of water in South Pond is fairly rapid, limiting the effects of copper sulfate treatment.

Wellhead Protection Area (WHPA)

In September 1997, the Atlantic States Rural Water Association completed a Wellhead Protection Plan for the Community of Jamestown (Reference Appendix E). This Plan contains the following: a delineation of the WHPA, an inventory of potential contamination sources, priority ranking of potential contamination sources, a wellhead protection management plan, a groundwater quality analysis of Community Well JR-1, and proposed management strategies. The delineated area is depicted on Figure 6.1. Land in the WHPA comprises approximately 280 acres.

This WHPP has not been updated; however, an update to the Source Water Assessment Plan (SWAP) was performed and is provided as Volume II of this WSSMP.



Figure 6.1
Source Water Map

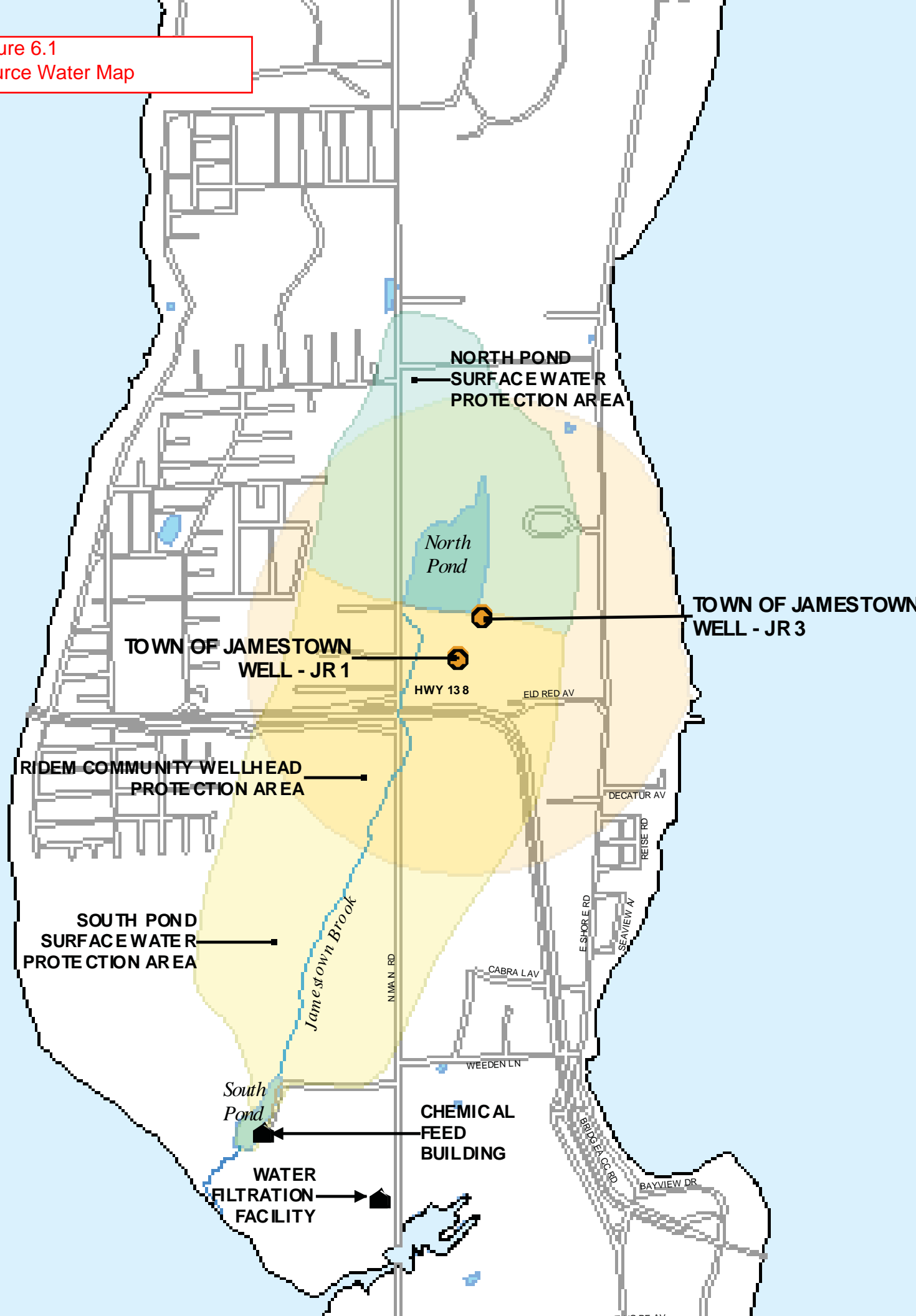

Analysis of Safe Drinking Water Act (SDWA) Requirements

Jamestown contracts with the Rhode Island Department of Health to perform periodic water quality testing procedures. Tests are performed weekly and quarterly. The beneficial effect of this arrangement is two-fold: (1) RIDOH has the best technical knowledge of the types of testing required for public water supplies, and (2) there is no transfer of information required since reports are filed with RIDOH.

Jamestown's public water does not exceed action levels for any contaminants. In fact, water quality is excellent from a health standpoint. The only complaints logged regarding public water have to do with color and taste. Because of the amount of organic matter both in the reservoirs and in the intervening wetland, raw water entering the system is tea-colored and bitter tasting. During most periods, treatment reduces these elements to undetectable levels.

Treatment Procedures

Raw water is pumped from either North Pond or South Pond to the treatment plant. Pre-chlorination is done at the South Pond pump station, so that it is effective during the transportation time to the treatment plant. The first treatment processes at the plant are screening, pH adjustment, and coagulation. Flow splits and is treated in parallel membrane filtration basins than receives disinfection and corrosion control additives. Procedures to remove volatile organic compounds (VOCs) and trihalomethanes (THMs) have not been necessary, as Jamestown's water is below the threshold for treatment.

Surface Water Treatment Rule

Raw water receives pretreatment from a chemical feed system located in a building at South Pond that feeds Chlorine Dioxide directly into the main to treat the raw water prior to it entering the treatment facility at North Road. Chlorine dioxide is highly soluble in water and is effective at disinfection and improving color, odor, and taste. The pretreatment facility was constructed in 1991 and has been in full operation since that time. Water flows through a screen at the head of the plant to remove large particulate matter prior to water entering the treatment system.

Lead and Copper Rule

The JWD has been, and currently is, below compliance levels for lead and copper. The 2022 Consumer Confidence Report (provided as Appendix F) summarizes lead and copper results for calendar year 2021.

Inorganic and Synthetic Chemicals

The JWD has been within or below compliance levels for inorganic and synthetic compounds in raw water sources and the distribution system.

Radionuclides in Drinking Water

The JWD has been within or below compliance levels for radionuclides in the water system.

Phase VIa: Disinfectants and Disinfection By-Products

The Stage 1 Disinfectants and Disinfection By-Products (D/DBP) regulation was promulgated on December 16, 1998. The D/DBP Rule (Stage 1) included MCLs for four trihalomethanes (0.080 mg/l), five most common Haloacetic Acids (0.060 mg/l), Bromate (0.010 mg/l) and Chlorite (1.0



mg/l). Maximum Residual Disinfectant Level Goals (MRDLG) of 4.0, 4.0 and 0.8 mg/l have been set for Chlorine, Chloramines and Chlorine Dioxide, respectively.

The Stage 2 Disinfectants and Disinfection By-Products (D/DBP) regulation was promulgated on January 4, 2006. The intent of the rule is to reduce potential cancer and reproductive and developmental health risks from disinfection byproducts (DBPs) in drinking water. The rule applies to community and nontransient noncommunity water systems that add and/or deliver treated water with a primary or residual disinfectant other than ultraviolet light serving less than 10,000. The rule requires systems to meet MCLs at a local running annual average at each compliance monitoring location for two groups of DBPs, Total Trihalomethanes (TTHM) and five Haloacetic Acids (HAA5). The running annual average TTHM concentration is below 80 parts per billion and the running annual average HAA5 concentration is below 60 parts per billion. The JWD is in compliance with the disinfection byproduct rule.

Groundwater Rule

The Groundwater Rule, referenced in the previous WSSMP for the JWD, went into effect in 2006, as anticipated. However, this rule does not apply to the JWD because they combine groundwater supply with surface water withdrawn from North Pond.



SECTION 7.0 DEMAND MANAGEMENT

7.1 General

Demand Management consists of conservation measures which achieve long-term water savings by providing incentives and technical assistance to the customer base as a means of improving efficiency of water use and reducing waste. Such water conservation measures, whereby suppliers and/or local water utilities work to influence water consumption, is the most fundamental approach to water conservation since the ability to conserve water lies primarily with the water user. Consequently, the success of these measures is highly dependent upon consumer participation and cooperation.

The JWD actively promotes a water conservation program by checking meter accuracy and addressing issues such as waste, detection of water leakage, promotion of conservation measures, and peak usage reduction.

7.2 Demand Management Strategy (2012)

The *Rules and Procedures Governing the Water Use and Efficiency Act for Major Public Water Suppliers* (Act) was enacted in 2011 to establish efficient water use targets for all major water suppliers in Rhode Island. The Act also required that major suppliers complete a demand management strategy (DMS), documenting how they would meet each of the specified goals.

7.2.1 Goals

The demand management goals required of major water suppliers identified in the Act includes:

1. Residential average annual water use of 65 gallons per capita per day (gpcd);
2. Efficient outdoor water use;
3. Efficient indoor water use;
4. A full accounting of non-billed water;
5. Leakage of no more than 10%; and
6. Accurate metering and billing.

In addition, the Act established required methodologies that must be employed in an effort to meet these goals, including:

- Initiating a program to accomplish 100% metering of all water delivered by December 31, 2012, as specified in R.I. General Laws §46-15.3-22(b).
- Initiating a program for the maintenance and replacement of meters by December 31, 2012, as specified in R.I. General Laws §46-15.3-22(b).
- Initiating a program for installing radio frequency reading systems by December 31, 2012, as specified in R.I. General Laws §46-15.3-22(b).
- Recording metered usage and bill quarterly or more frequently by December 31, 2013, as specified in R.I. General Laws §46-15.3-22(c).
- Educating customers in regards to efficient water use.
- Establishing rate structures that are adequate to fund all water supply costs, are equitable, sensitive to economic impacts, and encourage efficient water use, per R.I. General Laws §39-15.1-3 or §45-39.1.5 as applicable.
- Implementing leak detection programs in accordance with AWWA standards and initiating a system-wide leak detection program if leakage is more than 10% of the water purchased.



Other optional methods for meeting the efficient water use targets are also discussed in Part 4.0 of the Act. These include billing structures that encourage efficient water use, methods for reducing non-agricultural water use, efficient indoor water use strategies, and methods of improving water use efficiency by major users.

The JWD completed its Demand Management Strategy in 2012, which served as an addendum to Section 7 of their WSSMP. The following sections provide an update to the 2012 Demand Management Strategy.

7.2.2 Residential Average Annual Per-Capita Water Use

The residential average annual per capita water use in the JWD system was estimated to be approximately between 38.1 and 44.5 gpcd for the period from 2016 to 2022. These averages were based on total metered residential water use and a residential population of approximately 3,256 people in the service area. More recently, metered residential water use was 47.81 million gallons in 2022, which represents 39.4 gpcd based on an estimated 3,323 residents in the system.

Water use in the JWD system is impacted by seasonal changes in population to a greater degree than other water systems in Rhode Island. It is difficult to accurately compute the year-round population in the system, and it is acknowledged that seasonal population fluctuations have some level of impact on per capita water use estimates. However, the JWD has very little multi-family housing, which is often accounted for in the commercial customer base in other systems. Therefore, the JWD has a high degree of confidence that actual residential water use continues to meet the State's goal of 65 gpcd.

7.2.3 Efficient Water Use

The JWD has implemented programs to improve the efficiency of indoor and outdoor water use by its customers. Plumbing fixtures and appliances used in any new construction project must meet the JWD's water efficiency standards in order to be permitted for connection to the JWD system. The building code mandates that all new construction in Jamestown must be fitted with water conservation fixtures, including 1.5 gallons/flush toilet, sink faucet which takes 7.5 seconds to fill a quart container, and a shower head which takes 6.5 seconds to fill a quart container.

For existing homes, any replacement dishwasher, clothes washer, or other appliance using water must also meet these water efficiency standards. The JWD requires customers to file a permit with the JWD to ensure compliance with the water efficient standards. These standards are published in the JWD's Rules and Regulations, which are available on the Town's website (<http://www.jamestownri.gov/Home/ShowDocument?id=1465>).

The JWD established a Residential Retrofit Program (RRP) in the mid-1990s, offering complimentary retrofit kits to interested homeowners to assist them in conserving water. The kits are still available at the Town Offices and contain a low-flow showerhead, faucet flow-restrictors, a water displacement bag for toilets, and leak detection tablets. Efficient plumbing fixtures are now a requirement for all homes connected to the JWD system, and a quarterly surcharge is charged to any homeowner that fails to meet these requirements. Additionally, the JWD enacted a regulation in 1999 requiring that all clothes washers meet the Town's water efficiency standards by May 2014.

An outdoor water use ban has historically been imposed each year from June 1st to August 31st. Additionally, water use bans are put into effect when the water level at North Pond, the JWD's primary supply, falls more than 42 inches below the spillway elevation. Also, connection of lawn irrigation systems in the JWD supply system is strictly prohibited without prior approval. Violators



are called in front of the Board of Water and Sewer Commissioners and may be fined for failing to comply with the JWD's outdoor water use restrictions. These mandatory restrictions in outdoor water use are significant at maintaining relatively low per capita water use, as the vast majority of the service area is residential development of low to medium density.

A public information program promoting water efficiency is run through the Planning Department. The department periodically sends out press releases on the need to reduce water consumption and potential methods for implementing conservation practices. Brochures are made available to educate residents on voluntary conservation methods.

7.2.4 Full Accounting of Non-Billed Water

Non-billed water is defined as the difference between the amount of water withdrawn from the system's supply sources and the amount of water sold to the customer base. Typically between 70 million and 85 million gallons of water have been withdrawn from the JWD's supply reservoirs each year, while between 50 million and 65 million gallons of water are sold to customers based on meter readings. In 2022, approximately 61.17 million gallons was withdrawn from supply while metered water use was 53.90 million gallons.

Sources of non-billed water that the JWD accounts for in a typical year, and the estimated volumes of water associated with each are as follows:

- Fire Department Allowance: Typically 100,000 gallons annually;
- Hydrant Flushing: 100,000 gallons annually;
- Storm Drain Flushing: Typically 5,000 gallons annually;
- Sewer and Street Cleaning: Typically 10,000 gallons annually; and
- Process Water at Treatment Plants: Six (6) to twelve (12) million gallons annually, under normal operation. For 2022, the process water used at the treatment plants was 6.05 MG.

The remaining volume of non-billed water is unaccounted, of which the majority is attributed to leakage (1.0 million gallons annually in 2020 to 2022). Water theft, meter inaccuracy, and other miscellaneous withdrawals are believed to be relatively minor and likely represent a small portion of the total unaccounted water volume.

7.2.5 Leakage

The JWD reviewed the amount of water withdrawn from supply sources and compared it to the water sold and accounted for quantities of unbilled water to estimate leakage from 2009 – 2012 in the 2012 Demand Management Strategy. With the exception of 2010, which appeared to represent an outlier, leakage ranged from approximately 5% to 11% and averaged 8.6% annually. This met the State's goal for leakage of 10%. However, leakage in 2016 was estimated to be over 17%. This is a significant increase, and it is questionable whether this is a true reflection of leakage and it likely represents other non-billed water that has not been adequately quantified. Between 2020 and 2022, leakage has remained around 1.6%. This significant reduction in leakage as compared to previous years is the result of an on-going effort to monitor and repair problem areas when detected in the distribution system. The JWD routinely checks areas where leaks have been detected in the past. The JWD will continue to review their accounting of non-billed water and will monitor leakage in the system.



7.2.6 Metering and Billing

RI General Laws §46-15.3-22(b) required that a program for the installation of radio frequency read devices be initiated by December 31, 2012. It also required that major water suppliers initiate a program to accomplish 100% metering by December 31, 2012, in addition to establishing a meter maintenance and replacement program. RI General Laws §46-15.3-22(c) requires that meter reading and billing be performed at least quarterly by December 31, 2013.

The JWD is currently in compliance with these requirements. Between 1996 and 2000, each of the approximate 1,400 meters in the system were replaced with ARB style remote meters, and all new meters include radio-frequency readers. The system is entirely metered, and all customers are billed at least quarterly. Joint water and sewer bills are sent out each quarter to residential customers and monthly to commercial customers.

The JWD uses a rate structure that encourages water conservation while adequately funding system operations. A flat rate, based on meter size, is charged for the first 5,000 gallons of water used each quarter. The rates for water used beyond the first 5,000 gallons increase under an inclining block rate schedule. This is in addition to the surcharge billed to customers in violation of the JWD's strict water efficiency requirements.

7.3 Residential Retrofit Program (RRP) Plan

In response to the drought of 1993, the Town investigated the potential water savings created by a Residential Retrofit Program (RRP). The study culminated with a presentation by the RIDEM, Division of Water Supply Management to the Board of Water and Sewer Commissioners showing how much water would be saved by various retrofit measures.

As of May 17, 1999 the RRP is mandatory. The "Rules and Regulations of the Board of Water and Sewer Commissioners" mandated that within 5 years of adoption of these rules, all toilets, showerheads, and faucets in any property connected to the municipal water system, shall meet or exceed low-flow standards set by the Board. It was also required that all washers meet Energy Star efficiency requirements by 2014. In the event of a deed transfer, the above standards must be met prior to any sale.

The customer base is generally in compliance with these requirements. Residential retrofit kits are still available but are not typically sought after as most homes and businesses comply with the Board's efficiency requirements.

7.4 Major Users Technical Assistance Program

There are no major water users in Jamestown. Restaurants and overnight guesthouses are the largest water users. They are requested to use water efficiently and make reasonable efforts to conserve water.



SECTION 8.0 SYSTEM MANAGEMENT

8.1 Statement of Objectives

Water conservation practices involving system management initiatives are directed at improving the efficiency of, and reducing waste in, the production and distribution of water within a supply system. Such practices are necessary to ensure that the physical components of the water system are properly operated and maintained. Goals of system management include the following:

- Maintaining non-account water use to below 15% of the total system demand, in accordance with State Guide Plan Element 721;
- Maintaining leakage below 10% of system demand;
- Establishing a preventive maintenance program; and,
- Maintaining compliance with applicable requirements of the Rules and Procedures Governing the Water Use and Efficiency Act for Major Public Water Suppliers.

In order to maintain the long-term viability of the public water supply system, fiscal planning must be done to provide sufficient funding for necessary improvements and repairs. Proper management of the system requires that the JWD continuously monitor the condition of equipment and facilities, develop funding mechanisms for future capital expenditures, and respond to regulatory changes with regard to water quality and treatment methods.

The objectives of managing the Jamestown public water supply system are as follows:

- To maintain water treatment equipment to provide consistent, high quality drinking water to the customer base;
- To minimize water losses between the treatment plant and water customers;
- To plan for capital improvements to the water treatment system to maintain efficient plant operation;
- To plan for capital expenditures necessary to meet water quality standards set forth in the Safe Drinking Water Act;
- To meet the operating costs of the water treatment and distribution system;
- To keep costs borne by customers at the minimum level necessary to accomplish the above objectives.

8.2 Meter Installation, Maintenance, and Replacement (MIMR) Plan

The JWD is in compliance with RI General Law §46-15.3-22(b). All residential and commercial water services on the public water supply system are metered, and all meters are equipped with radio-frequency automatic meter reading (AMR) units.

The JWD continues its program of meter testing and replacement. The American Water Works Association publication, Water Meters – Selection, Installation, Testing and Maintenance offers standards for meter performance and maintenance which the JWD uses as a guide. Ranges of meter accuracy should be in line with the latest revisions of the AWWA standards (6700 Series) and the State Plumbing Code. Where an AWWA standard for a meter is not available, the Water Department shall demonstrate that the meter is capable of measuring not less than 95% and not more than 105% of the water that passes through the meter. Information on individual water meters is maintained at the Water Department office, and file cards are used to record data relative to meter



performance, repairs, and accuracy of metering at the time the meter was installed. Also, all meter testing information is documented and maintained at the Water Department offices.

Because of the relatively high cost of repairing water meters, most meters will be replaced rather than repaired if they do not perform to AWWA meter standards. New meters are more efficient in their ability to accurately measure water consumed and meters generally “slow down” over time, resulting in an underestimation of water consumption. Generally speaking, residential and small commercial meters have a useful life of approximately 15 years. Most of the meters in the system were installed around 2000, and the JWD should plan for their replacement.

Master meters located at the treatment plant wetwell and finished water pump station will be tested and calibrated annually and repaired or replaced as necessary.

8.3 Leak Detection and Repair (LDR) Plan

The Water Department possesses an electronic detection device used to locate leaks in water lines. This device is used to determine the exact location of a leak prior to ground excavation. Leakage is monitored by the JWD to ensure that it meets the State’s goal of no more than 10% of total water in the system. While leakage fluctuates from year to year, the JWD has generally complied with this. Also, the JWD has performed several system improvements over the last 15 years, including replacement of over 2.5 miles of aging pipe prone to breaks and leakage since 2005, which has contributed to relatively low leakage.

Conanicut Island is composed primarily of bedrock with relatively little overburden soil. Because of this, water leaks usually saturate the soil layer and rise to the ground surface where they are often visually identified and reported to the JWD by local officials or residents. Public awareness of the importance of water conservation on the island is such that virtually any leak is reported quickly and by multiple parties. All known leaks receive priority treatment for repair and repairs are made as soon as possible.

8.4 Preventive Maintenance (PM) Plan

The PM Plan is organized around a magnetic yearly calendar board system. All major pieces of equipment are charted and moved on a monthly basis on the calendar board. The maintenance functions are summarized on individual clips and placed on the board at the appropriate month. After the maintenance function is completed, the clip is advanced to the month of the next scheduled maintenance task. Each completed task is recorded on a file card system.

Hydrant flushing and valve exercising is accomplished in the spring/early summer. Each hydrant is flushed clear and appropriate valves are exercised to direct flow to individual hydrants. The schedule is published in the *Jamestown Press* with the usual customer warnings as to laundry staining.



Maintenance Schedule

The following is a list of the major pieces of equipment that are regularly serviced and maintained:

<u>Component</u>	<u># of Items</u>
Chlorine Dioxide Generator	1
Flow Recorder - South Pond	1
Influent Pumps	3
Zenon Membrane Filter	2
Metering Pumps	12
Backwash Pumps	2
Effluent Pumps	2
Generator	1

Spare parts are maintained as required to replace normal wear parts, along with preventive maintenance kits from the manufacturers. Spare valves, pipe, repair clamps, bends, reducers, etc. are kept in stock for every known size and type of material in the distribution system.

Spare Parts Inventory

Spare parts are stored at the water plant for all essential equipment. A list of equipment vendors is kept on file at the water plant, so that they can be notified immediately if emergency service is needed on any equipment.



**SECTION 9.0
EMERGENCY MANAGEMENT**

9.1 Emergency Management Planning

As a sole source water provider, Jamestown guards its watershed. Being situated on an island, the JWD has no quick and reasonable alternative water sources in case of emergencies. As a result, the JWD uses the following Emergency Management procedures to deal with a variety of potential emergency situations.

9.2 Known and Potential Risks to Water Supply System

Many of the potential water emergency scenarios would have similar impacts on critical system components. Critical system components include the treatment plant, supply sources, pump station, two standpipes, and transmission mains. These components were described in Section 2 of this WSSMP.

Table 9.1 describes the potential impact emergencies might have on various system components.

**Table 9.1
POTENTIAL SYSTEM IMPACTS UNDER VARIOUS EMERGENCY CONDITIONS**

IMPACT	Interrupt Supply	Loss of Treatment Plant	Loss of Standpipe	Loss of Pump Station	System Contamination	Prolonged Power Loss
Hurricane	•	•	•	•	•	•
Drought	•					
Earthquake	•	•	•	•	•	•
Hazardous Material Spill	•				•	
Plane Crash		•	•	•	•	•
Vandalism	•	•	•	•	•	•

9.2.1 Hurricane

Because of Jamestown’s location at the mouth of Narragansett Bay, a hurricane or major storm could cause significant damage to the water system. Current FEMA flood maps show that the storm surge from a severe hurricane could inundate South Pond, the raw water pump station, and the Treatment Plant. This scenario would incapacitate the production system, forcing residents to rely solely on standpipe storage for potable water. Hurricanes could also present power outages. A long-duration power outage could have a significant impact on the treatment plant and pump station.

The Town has a Hurricane Preparedness Plan. The plan describes the duties of all local officials in dealing with a hurricane. The plan requires an annual bench top drill be performed in the middle of summer in preparation for the hurricane season. Hazardous material training drills are scheduled quarterly. Employees are certified at the Technician Level for handling chlorine gas. A copy of the plan can be found in Appendix G.



Scenario – Hurricane

Potential Conditions:

1. South Pond contaminated with seawater.
2. South Pond pump station, treatment plant flooded.
3. Long-duration power outage at the treatment plant and pump station, prohibiting transmission of water to system.
4. Clearwell and standpipe storage are not damaged.
5. Finished water storage filled to capacity.

Remaining System Capacity:

1. The useable storage in each standpipe is 0.7 million gallons, or 1.4 MG collectively.

Response:

- Limit water consumption to 2 gpd per person to meet only basic needs. This would be accomplished by rationing water from central locations in Town, by authorities, to each homeowner in the water district upon presentation of proper identification.

9.2.2 Drought or Seasonal Water Storage

Jamestown Water Department (JWD) relies on two surface reservoirs for its water supply. The reservoirs are fed almost entirely by precipitation runoff. As a result, the system is vulnerable to the effects of periodic drought conditions. The public water system is also currently drawing a greater volume than the safe daily yield of North Pond, the primary supply source at certain times of year. This causes great fluctuations in the amount of usable stored water in the reservoir from year to year.

A worst-case scenario would be an interruption in the water supply to some or all customers. In this scenario, potable water would be rationed to residents at the rate of 2 gallons per person daily. In order to be prepared for firefighting a minimum of 0.6 MG will be retained in the standpipe. This volume is sufficient for 3 hours of firefighting, which should be able to extinguish most residential fires and provide ample time to request assistance from adjacent communities.

Scenario – Drought

Potential Conditions:

1. Partial or complete loss of water supply due to insufficient storage in reservoirs.
2. Maintain standpipe at maximum capacity.

Remaining System Capacity:

1. Treatment plant capacity will depend on the severity of conditions.
2. Connection to emergency supply in North Kingstown may be restricted, depending on the regional impact of drought conditions.

Response:

- Invoke mandatory conservation requirements detailed above.

See Section 10 of this WSSMP for more details on Drought Management.



9.2.3 Earthquake

Earthquakes are rare in Rhode Island relative to other parts of the country. They do, however, occur from time to time. Up to this time, earthquakes in the area have been very mild. Some scientists have theorized that the Northeast United States could be prone to an earthquake sometime within the next fifty years.

A severe earthquake could totally incapacitate the water treatment and delivery systems. It can result in structural damage and/or prolonged power outages. In these cases, the Town would activate its primary control center. The Public Works Director is responsible for initial assessment of the situation, and shall notify the Town Administrator and confer on proper response. The Rhode Island Department of Transportation shall be notified, and public information on the situation disseminated via the emergency broadcast system.

JWD personnel shall inspect all critical components including: pump shafts, pumps, treatment equipment, mains, and the standpipe. A damage report shall be made to the Public Works Director, who shall notify the Town Administrator and Board of Water and Sewer Commissioners.

If the system is damaged, the Public Works Director shall immediately investigate alternative means of supply. The RI Department of Health shall be notified immediately and appraised of the situation. Component vendors and/or distributors shall be contacted as soon as possible to begin repairs. If there is no apparent damage to the system, water quality shall be monitored and appropriate action taken to ensure that water in the system meets quality standards.

Scenario – Earthquake

Potential Conditions:

1. Major structural damage to treatment plant, pump station, and standpipes possible.
2. Damage to water transmission line from North Pond.
3. Water main breaks in distribution system.
4. Integrity of reservoir dams compromised.
5. Standpipe damaged.

Remaining System Capacity:

1. Treatment plant capacity will depend on the severity of emergency conditions.

Response:

- Invoke mandatory conservation requirements detailed above.
- Inspect all critical components. Determine if any level of normal service can be maintained.
- Inspect dams. If potential for breach exists, evacuate watershed below North Pond and monitor condition.
- Damage to standpipe will require that emergency supply of potable water be secured. Make sources available at central locations at rate of 2 gpd per person to meet only basic needs.
- Immediately begin repair procedures, beginning with major components and transmission lines.



9.2.4 Hazardous Material Spill

Potential for a hazardous material spill includes a release of treatment plant chemicals or an unrelated spill off-site within the Jamestown Watershed. The latter could be caused by a vehicle or airplane crash, fire, or explosion. Either type of incident could result in contamination of finished or raw water.

The most likely cause is a vehicular accident on Route 138, a limited-access highway that bisects the watershed. The highway drainage system is designed to capture all stormwater runoff and transport it to one of two detention ponds. In order to cause an emergency condition to the watershed, an accident would have to occur outside the containment area of the highway.

A hazardous material spill could have numerous effects. First, the raw water quality of the reservoirs could be compromised. A second impact might be restricted access to or use of water system components. There would also be impacts to public water customers and the environment. Possible effects of a hazardous material spill on the JWD's water customers could range from a lack of available water to consumption of contaminated water.

In preparing to deal with a hazardous materials incident, the JWD requires comprehensive training of personnel. Emergency preparedness training includes an orientation seminar. Personnel are given an overview of the entire system and facilities, and the Emergency Preparedness Plan is presented and discussed. Employees are detailed on every aspect of their anticipated involvement to respond to an emergency situation.

Supervisors are required to undergo more rigorous training. All supervisors receive cross-training in systems operations so that they are able to operate all system components. Lower-level supervisors are trained to make management decisions in the event of an emergency.

All JWD personnel go through a 40-hour OSHA Hazardous Material Response Training course and are required to attend periodic AWWA seminars in water quality management. Supervisors are required to attend an additional 8-hour OSHA training. Personnel also attend AWWA backflow prevention courses and quality/microbiology seminars regularly. To further prepare for an emergency, the JWD engages in mock emergency exercises. A tabletop exercise is conducted at least annually to keep all personnel and elected and appointed town officials up to date on their emergency duties.

In the event that a hazardous spill should occur, several agencies should be notified, many specific to this type of emergency. These are as follows:

RI Department of Environmental Management (DEM)	(401) 222-4700
RI DEM After Hours Emergencies	(401) 222-3070
US EPA Region 1	(617) 918-1111 or (888) 372-7341
National Response Center	(800) 424-8802
RI Department of Health	(401) 222-5960
Clean Harbors Field Services	(401) 228-2435



The Fire Department shall be dispatched immediately to the site and will utilize the spill containment kits in the event of a spill. The kits are stored at the Fire Station and near Route 138 within the watershed. The Public Works Director shall assess the situation to determine the degree of the spill and the appropriate response.

9.2.5 Civil Unrest

Civil unrest could result in a work stoppage impacting operation of the water treatment plant or general system maintenance. This situation could result in a loss of union personnel, in which case the JWD would suspend non-essential operations.

If the Public Works Director and Town Administration fear that security could be a concern, a police detail and/or National Guard personnel would be dispatched to the treatment plant. Regular drive-by surveillance would be done at the reservoirs, standpipe, hydrants, and other exposed equipment of the distribution system.

The JWD will consider hiring private contractors to run the treatment plant in the event of a work stoppage. In this situation, outside personnel may require police escorts to the work site.

9.2.6 Vandalism

Because of the size of the watershed area and the distribution of various components, it is impossible to defend against vandalism of the entire system.

Because of the small size of the water system, a release of water from a hydrant would be detected within minutes. A broken hydrant, however, could allow enough water to escape to lower the standpipe elevation, which would cause a decrease in water pressure and storage. This would be a temporary situation that would not result in damage to the system. JWD personnel indicate that the most probable cause of system damage from a hydrant release would result from shutting off the hydrant too quickly. This situation creates a pressure “hammer” which can cause damage to weak pipes.

Vandalism associated with hazardous material being introduced into the system would be handled as detailed in section 9.2.4 above.

Scenario – Vandalism

Potential Conditions:

1. Damage to treatment plant.
2. Contamination of reservoir.

Remaining System Capacity:

1. Incapacitation of treatment plant would result in zero production.
2. Contamination of reservoir would require utilization of emergency supply in North Kingstown.

Response:

- Dispatch personnel to site to assess situation.
- In the event of contamination, notify agencies listed in hazardous spill section.
- Contact North Kingstown Water Department for emergency supply.



9.2.7 Other Extraordinary Emergencies

1. Fire – The Treatment Plant is brick and masonry construction. All electrical systems are enclosed in steel panels. The Plant’s electrical contractor, Jack’s Electric, would be called in for fire damage to electrical systems.
2. North Pond Contamination, Hazardous Material Spill – the intake from North Pond would immediately be closed. Chemical containment kits, which are stored in the watershed and at the Fire Department, would be placed as needed. Clean Harbors, Inc. would be dispatched by the Police Department. The Treatment Plant would begin taking water from South Pond with RIDOH approval.

The above emergencies constitute the greatest threats to continuous service of the public water system. An emergency generator is maintained at the water treatment plant to provide power for all necessary functions. Should a pollution event occur, the Town would be forced to seek water from an outside source.

9.3 Problem Identification/Assessment

Identifying the emergency situation and assessing its impacts on the system is a critical first step needed to determine which system components are impacted and what general and specific responses are required. The following is a procedure for assessing the water system emergency before response actions are taken.

1. Determine whether the emergency reduces the quantity and/or quality of potable water in the system.
2. Assess the extent of the emergency and assign the severity of the water quantity or water quality type of emergency.
3. Determine the cause of the emergency so that appropriate specific responses can be selected.
4. Identify critical system components impacted, or those that are vulnerable to impacts, from the emergency conditions.

9.4 General Responses

In instances where the water quality or available quantity has been reduced, general response actions should be taken to mitigate the potential consequences from reduced water quantity or quality. The following general responses are appropriate for most types of emergencies typically facing water systems:

1. Notify RIDOH of impending public health emergency condition.
2. Notify RI Emergency Management Agency to coordinate state resources, possibly including RI National Guard, local fire and police departments, local emergency maintenance agencies, and other agencies as applicable.
3. Implement emergency notification procedures through the Statewide Emergency Broadcast System to instruct water system customers of the emergency water event.
4. Restrict water usage as required based on the severity of the emergency.
5. Notify North Kingstown Water Department if activation of the emergency interconnection is considered.
6. If deemed necessary, utilize state resources to implement potable water distribution in affected areas for the expected duration of the water emergency condition.
7. Identify critical components impacted by the emergency and implement specific response actions.



-
8. Flush and disinfect system components impacted upon resolution of emergency, as appropriate.
 9. Prepare a situation report and submit to RIDOH within 10 days of the resolution of emergency condition.

9.5 Specific Response Actions

Response actions likely required for a number of types of emergencies are summarized in Section 9.2. Response actions specific to the various types of critical infrastructure in the JWD system are summarized in this section.

9.5.1 Treatment Plant

The JWD relies on one treatment facility to treat source water from their supply reservoirs and wells.

Treatment Plant Damaged and Out of Service

Severe structural damage or a contamination event at the treatment plant is possible during certain types of emergencies which might remove it entirely from service and cut off supply of treated water to the distribution system. In this event, notification procedures outlined in Section 9.6 shall be implemented and an emergency response team mobilized to the damaged facility to assess the damage. Necessary repairs shall be made by water department staff or outside contractors, as required, to reinstate operation of the treatment plant as expeditiously as possible. The JWD shall also coordinate with the North Kingstown Water Department to activate the emergency interconnection, if warranted.

Failure of a Piece of Equipment

Although the treatment plant is equipped with redundant equipment and multiple treatment trains, failure of a piece of equipment can restrict production capabilities to the point where a short-term emergency condition may ensue. Upon such an occurrence, a precautionary restricted water use condition shall be considered and implemented, if warranted. This shall be coordinated with the RIDOH, Division of Drinking Water Quality, in addition to other state and local emergency management authorities. Damaged or failed equipment shall be isolated and a response team shall assess the situation and determine the repairs necessary to return it to service. Repairs shall be made by JWD staff or outside contractors, as deemed appropriate based on the degree of equipment failure.

9.5.2 Pump Station

The pump station pumps finished water from the treatment plant to the two standpipes, which supply the distribution system.

Pump Station Damaged and Out of Service

Severe structural damage to the pump station is possible during certain types of emergencies which might entirely cut out supply to the two standpipes and the distribution system. In this event, notification procedures outlined in Section 9.6 shall be implemented and an emergency response team mobilized to the damaged facility to assess the damage. Necessary repairs shall be made by water department staff or outside contractors, as required, to reinstate operation of the pump station as expeditiously as possible.



Failure of a Piece of Equipment within the Pump Station During Operation

Although the pump station is equipped with two pumps, and thus capable of absorbing the short-term loss of a single pump, an emergency situation involving the failure of electrical and mechanical systems, or even both pumps, is possible. The pump station is integral to the system by supplying the two standpipes with finished water from the treatment plant.

Upon such an occurrence, a precautionary restricted water use condition shall be immediately implemented for the affected area and coordinated with the RIDOH, Division of Drinking Water Quality, in addition to other state and local emergency management authorities. Care shall be taken to monitor drawdown of the two standpipes. The failed pump(s) shall then be isolated and an emergency response team shall assess the situation and determine the repairs necessary to return the failed pumps to service.

9.5.3 Storage Tanks

The two standpipes in the JWD system provide for flexibility in water supply operation and facility storage is utilized for normal operation during system peak demand periods. Storage also assists in providing for system-wide fire flow demands.

Loss of a storage tank could result from an emergency event causing structural damage to the facility or contamination of stored water within the tank, requiring it to be removed from service for decontamination. Emergency events in which both standpipes are impacted are obviously more critical than if one of the standpipes is compromised, since they generally serve a similar function.

Tank Damaged and Out of Service

Upon severe structural damage and collapse of the tank, the facility shall be bypassed and taken off-line. In addition, the local Fire Departments shall be notified of the loss of this storage, and any remaining water shall be drained. System demand shall be monitored during periods of peak demand while the storage tank is out of service. Once the damaged tank is isolated, an emergency response team shall assess the situation and determine the repairs necessary to return the damaged tank to service.

Tank Contaminated and Out of Service

Should the tank become contaminated in any way, bacteriologically or otherwise, the facility shall be bypassed and taken off line. In addition, the local Fire Departments shall be notified of the loss of this storage.

Once the contaminated facility is isolated, an emergency response team shall assess the situation and determine the necessary mitigating action. Recommended procedures for adequate decontamination shall then be implemented and coordinated with the RIDOH, Division of Drinking Water Quality, and other state and local emergency channels. This will involve disinfection, draining of the tank, sampling, testing and refilling upon acceptance.

It should be noted, that under these conditions, portions or in fact all of the distribution system should be placed in a precautionary restricted water use condition. Aside from moving to effect repairs to the tank, action should be undertaken to impose service restrictions on water usage until normal system storage can be reinstated.



9.6 Notification Procedures

Quick and effective communication is an important factor in responding to an emergency situation. If a condition is found to exist which threatens water quality or supply quantities, the following agencies and key personnel should be notified.

1. Local Management and Emergency Personnel:
 - a. Public Works Director (401) 423-7225
 - b. Town Administrator (401) 423-7220
 - c. Jamestown Emergency Management Director
 - d. Jamestown Police Department (401) 423-1212
 - e. Jamestown Fire Department (401) 423-7277
 - f. Other Town Personnel, as appropriate

2. State and Other Local Officials:
 - a. North Kingstown Water Department, Director (401) 268-1521
 - b. RI Department of Health, Office of Drinking Water Quality (401) 222-6867
 - c. RI Department of Environmental Management (401) 222-4700
 - d. RI Emergency Management Agency (401) 946-9996

3. Media and Public:
 - a. Providence Journal (401) 277-7623
 - b. Newport Daily News (866) 758-3408
 - c. Jamestown Press (401) 423-3200
 - d. WPRI CBS 12 (401) 438-3310
 - e. WLNE ABC 6 News (401) 453-8000
 - f. WJAR NBC 10 (401) 455-9100
 - g. WPRO (401) 438-9776
 - h. WHJJ (866) 920-9455
 - i. Emergency Broadcast System through RIEMA

4. Other Utilities:
 - a. Rhode Island Energy - Gas (800) 870-1664
 - b. Rhode Island Energy – Gas Emergencies (800) 640-1595
 - c. Rhode Island Energy – Electric (855) 743-1101
 - d. Verizon (800) 837-4966

9.7 Recovery and Reverse Triggers

Regardless of the emergency condition, the system will generally be returned to normal operation at some point. The following general provisions should be implemented to return to the system to normal operation:

1. Identify that the emergency situation no longer exists;
2. Obtain approval, as necessary, from the appropriate authority to restore normal operation;



-
3. Perform testing on the restored facility and restore partial operation while monitoring operating conditions;
 4. Confirm operation appears normal and perform additional testing before placing component into full, normal operation.

9.8 Preventative Measures

An important aspect of emergency response is system preparedness. To adequately respond to an emergency/disaster event affecting the system, knowledge of the system and the proper response action, as well as adequate resources, must be available. The preparedness of the system relates to ensuring that knowledge of the proper response actions is thoroughly ingrained within the SWSB's personnel and that the resources needed for the implementation of response actions are available under all reasonably expected circumstances. The aspects of system preparedness fall into three basic components: Training, Resource Coordination, and Plan Updates. The basic requirements of these components are as described in the following section.

9.8.1 Training

Appropriate personnel must be properly trained and organized in order to ensure an efficient and effective response to emergency conditions. All appropriate new personnel are to be given an orientation training session, which should include the following:

- A general description of the water system and its facilities.
- A brief overview of this Emergency Response Plan; and
- A detailed description of the employee's anticipated involvement in emergency response (i.e. location of emergency control centers; who and where to report in case of emergency; etc.).

Employees acting in a supervisory or management role in the water system operation, and who are expected to be utilized as a resource during an emergency response, are to be thoroughly trained in all aspects of the JWD's emergency response procedures. This training will include the following:

- A thorough review of this section of the WSSMP. Each operating management/supervisory person will have their own copy (or access to a central copy) for immediate use during a water system emergency.
- All water system management personnel will be cross-trained in system operations outside their own areas of expertise (i.e., meter readers trained in transmission/distribution operations, etc.) for emergency response in other areas, as required.
- Lower-level management personnel should be trained in management decision-making procedures in the event of an emergency response where senior management personnel cannot be present.

The main goals of management training are to make management personnel thoroughly aware of emergency preparedness and to ensure that an adequate response does not rely upon a single decision maker who may not be available during an emergency event.



Specialized training should be consistent with the anticipated risks that are applicable to the water system. With the exception of training for emergency operational situations the primary risks to the water system would be in contamination of the distribution system due to backflows or cross connections. Appropriate personnel should be provided with the following training:

- OSHA 40-hour training for hazardous material response
- OSHA 8-hour supervisor training for hazardous material response (for supervisory personnel)
- AWWA Seminar for Emergency Planning for water quality management.
- NEWWA/AWWA Cross-Connection Control and Backflow Prevention courses.
- AWWA Water Quality/Microbiology Seminar (for water quality monitoring personnel).
- FEMA Emergency Management Institute Courses:
 - IS 100 – Introduction to Incident Command System (ICS 100)
 - IS 200 – Incident Command System (ICS) for Single Resources and Initial Accident Incidents
 - IS 700 – National Incident Management System (NIMS): An Introduction

In addition to these specialized training seminars listed, water system management should ensure that system operations personnel maintain an active and ongoing program of skills training through local trade associations, such as the New England Water Works Association.

9.8.2 Mock Emergency Exercises

Mock training exercises should be performed to ensure that emergency personnel are able to respond adequately to identified problems and ensure that equipment and resources are adequate prior to an actual event. By utilizing mock exercises as part of the overall training program, and as a part of the periodic review and revision activity, individuals will obtain firsthand experience with the response plan. Mock exercises can also indicate necessary areas of improvement for the plan. There are three specific types of mock exercises:

- **Tabletop Exercise:** This activity is designed to identify problems based upon the emergency response procedures. Elected or appointed personnel with emergency management responsibilities (primarily the command group) are gathered together to act out various simulated emergency situations. The exercise scenarios should test the performance of duties, tasks, or operations in a manner similar to the way they would be performed in a real emergency. Modifications to the emergency response procedures usually occur in response to this activity.
- **Functional Exercise:** This activity is designed to test or evaluate the capability of personnel to respond to individual or multiple functions. This type of exercise is more complex than a tabletop exercise in that activities are under time constraints and involve an extensive evaluation/critique at the end of the exercise. An example of a functional exercise would be an activity designed to test and evaluate the centralized emergency operations capability and timely response of one or more units of government under a given scenario. Functional exercises should be conducted from the emergency operations center and should accurately simulate the use of outside agencies and resources.



-
- **Full Scale Exercise:** This activity should evaluate the operational capability of emergency management systems in an interactive manner over a substantial period of time. It involves the simulated testing of a major portion of the basic elements existing within emergency operation response plans. This type of exercise includes mobilization of personnel and resources and the actual movement of emergency workers, equipment, and resources required to demonstrate emergency coordination and resource capability. The emergency operations center should be activated and field command posts may be set up. Extensive use of outside agencies should be considered to better simulate an actual disruptive event.

9.9 Emergency Sources

The Town of Jamestown currently has an agreement with the Town of North Kingstown to purchase water in the case of a water emergency. The connection has the capacity to transport water at the rate of 150 gpm, but is limited by the current contract of 200,000 gallons per day. The Town has maintained a written agreement with North Kingstown from September 15, 1993 to present. A copy of the most recent agreement can be found in Appendix C.

An emergency connection to the Newport water system is also feasible, but would require significant expense in installing a pipeline over the Newport Bridge or under the East Passage of Narragansett Bay. A connection to Newport is not currently a serious consideration.

The RI Emergency Management Agency is the contact for the RI National Guard. The National Guard is able to provide water via tank truck in the most severe cases of supply or distribution problems. The JWD monitors the reservoir levels daily throughout the year.



SECTION 10.0 DROUGHT MANAGEMENT

10.1 General

A drought event is not immediate but occurs over a period of time. State Guide Plan Element 724 defines five phases of drought consistent with the Drought Watch/Warning System of the National Weather Service, which are:

1. Normal;
2. Advisory;
3. Watch;
4. Warning; and
5. Emergency.

The Water Resources Board administers these phases with aid from the Drought Steering Committee. Drought conditions are evaluated on a regional basis across the state and are assigned based on conditions represented by major hydrologic indices, including precipitation, groundwater levels, stream flow, and the Palmer Drought Index. The Rhode Island Water Resources Board and Drought Steering Committee evaluate the major hydrologic indices and adjust drought levels both state-wide and on a regional basis, accordingly. The JWD system is within Rhode Island's Eastern Drought Region.

10.2 System Operation in Drought Conditions

The summer drought of 1993 caused the JWD to set specific guidelines for graduated conservation measures from May to November which are still in use today. The following are the steps activated by the level of the reservoir as measured from full capacity:

- | | |
|--------|--|
| Step 1 | <u>Capacity to -6" below capacity</u>
No restrictions |
| Step 2 | <u>-6" to -1' below capacity</u>
Public notification – voluntary conservation. |
| Step 3 | <u>-1' to -2' below capacity</u>
Restrict outside water use to odd/even days for residential use. |
| Step 4 | <u>-2' to -3' below capacity</u>
Reduce water pressure 5 psi.
Continue public notification for voluntary conservation. |
| Step 5 | <u>-3' to -3.5' below capacity</u>
Reduce pressure 5 psi.
Establish a residential ban on car washing and lawn watering.
Restrict swimming pool filling. |
| Step 6 | <u>-3.5' to -5' below capacity</u>
Ban outside water use entirely. |



-
- | | |
|--------|---|
| Step 7 | <u>-5' to -6' below capacity</u>
Reduce pressure 5 psi.
Restrict water use at marinas to potable water use only.
Begin commercial carwash and other non-essential commercial use restrictions. |
| Step 8 | <u>-6' to -7' below capacity</u>
Restrict all non-essential water use. |
| Step 9 | <u>-7' to -8' below capacity</u>
Reduce pressure 5 psi.
Continue restrictions on all non-essential water use. |

There is no formal procedure for restricting water use beyond Step 9. In 1993, the drought reached Step 7. Water conservation resulted in a reduction in use of 20%. If a situation arises which requires further restriction of water use, all commercial and industrial users will be restricted.

As an additional effort to conserve water, JWD has the following rules to control use:

1. No customer shall connect an in-ground or underground irrigation or sprinkler system to the municipal water system. Lawn irrigation shall be prohibited from June 1 to August 31.
2. No customer shall use water furnished by the municipal water system for lawn irrigation, house washing, boat washing, or residential car washing when the height of North Pond is more than 42 inches below the top of the spillway and after publication of said information in a daily or weekly newspaper of general circulation within the Town of Jamestown.
3. When the height of North Pond is from 42 inches to 60 inches below the top of spillway and after publication as noted above, no customer shall use water furnished by the municipal water system for any outdoor use.

10.3 Agreements with Other Water Systems

The JWD currently has a non-permanent emergency interconnection with the Town of North Kingstown as detailed in Section 2.5. The emergency interconnection, nine step drought management program, and experience of the 1993 drought provide security and insurance to aid the JWD with emergency situations such as drought and encourages a proactive approach at responding to drought.



11.0 PLAN IMPLEMENTATION

General

The purpose of this WSSMP is to outline the goals of the water supply system management planning process for the Jamestown Water Supply Board System, and to serve as a guide for the Board's decision-making procedures. The purpose of this section is to catalog actions necessary for the implementation of the WSSMP's recommendations in a timely fashion. The implementation section will therefore serve to link those recommendations resulting from comprehensive study, to policy and financial decisions required for actual improvement of the water supply system.

A primary objective of the JWD is to maximize the sustainable use of their current water supplies, which is of heightened concern given the lack of alternative supply on the Island.

The JWD is also exploring a potential opportunity for a watershed recharge project that might benefit water supplies. Currently, a stormwater pump station operated by the Rhode Island Bridge and Turnpike Authority (RIBTA) on North Road pumps stormwater from portions of Route 138 and North Road ultimately to the Bay. However, it may be possible to redirect this discharge to a location that recharges the watershed to North Pond. Pare has assisted the JWD with developing conceptual alternatives for redirecting the discharge from this pump station. At this time, the JWD is pursuing preliminary discussions with the RIBTA to further discuss the feasibility of these modifications.

The JWD is currently pursuing modifications at the treatment plant to include a pumping system that recirculates treatment plant backwash water to the head of the plant, as opposed to discharging it to Great Creek which is the current practice. It is anticipated to be completed soon and is estimated to save the JWD approximately 6.05 million gallons annually once completed. Other projects the JWD envisions completing in upcoming years are related to the continued maintenance of the system. The JWD anticipates performing routine leak detection surveys, water main replacement projects in Narragansett Avenue, and repainting of their original standpipe.



12.0 FINANCIAL MANAGEMENT

12.1 General

The JWD is operated as an enterprise fund, and is self-supporting. Revenues generated from water rates are used to meet the fixed, capital, operating, and administrative expenses of the water system. The Board of Water and Sewer Commissioners set water rates, and the utility is not regulated by the Rhode Island Public Utilities Commission (PUC).

Debt service for capital improvements is generally paid from annual revenues. The JWD is currently paying the debt service on a \$6.2 Million Clean Water SRF loan issued in 2007, set to reach maturity in 2027, as well as two other small bonds.

12.2 Current Financial Management Practices

Table 12-1 summarizes the revenue and expenses for the Jamestown Water Department for Fiscal Years 2020, 2021, and 2022.

Table 12.1: Jamestown Water Total Revenue & Expenses (2020-2022)

	2020	2021	2022
Total Revenue	\$1,218,968	\$1,343,859	\$1,396,314
Total Expenses	\$1,080,257	\$1,092,892	\$1,104,677
Total Income (Loss)	\$138,711	\$250,967	\$291,637

An independent accounting firm audits financial records annually. A summary of the budgetary and actual revenues and expenses, as well as the long-term debt status, for Fiscal Years 2020, 2021, and 2022 is presented in Appendix H. A review of revenues and expenses for the last three years can also be found in Worksheet No. 16.

12.3 Future Revenue Sources

The Water Department will continue to seek the most cost-effective means of financing future capital expenditures. It is anticipated that future revenues will be derived from water rates in most instances, though loans and grants may be pursued for large-scale capital improvements. The JWD does not anticipate performing any large capital improvement projects in the water system at this time, but routine maintenance of existing components will likely be required.

There are a variety of options for financing capital improvements to the water system in the event borrowing is required. These are listed below:

- *Town General Obligation Bonds*
- *Water System Revenue Bonds*
- *RI Clean Water Protection Financing Agency Loans*
- *RI Water Resources Board Loans*
- *Farmer's Home Administration Loans*
- *Other state and federal loan programs*



One option to using the above financing methods is forming a reserve fund from water rates that can be used to finance improvements without incurring debt.

Section 11.0 of this Plan discussed programs that will be implemented by the JWD in the coming years. For the current and succeeding years, the cost of these programs will be covered by revenues generated from water rates.

12.4 Assessment of Rates

Bills for residential and commercial customers are issued quarterly. Tables 12.1, 12.2, and provide the current rate structure for public water use, effective as of June 2022:

Table 12.2
WATER RATES - MINIMUM IN ADVANCE CHARGES

Source: Jamestown Water Department

Meter Size	Quarterly Billing Rates	Seasonal Billing Rates	Miscellaneous Charges
5/8"	\$89.82	\$340.84	Turn-on/off \$30.00
3/4"	\$134.80	\$511.59	Install/Remove \$100.00
1"	\$167.42	\$635.36	Early Install/Remove \$50.00
1-1/2"	\$206.22	\$781.78	Sprinkler Charge/unit \$0.18
2"	\$268.63	\$1,019.50	Frozen Meter Charge \$125.00
3"	\$495.25	\$1,879.56	Special Reading \$20.00
4"	\$745.46	\$2,828.23	Call Out \$150.00
			Lien Discharge Recording Fee \$49.00

Table 12.3
CURRENT EXCESS WATER RATES

Source: Jamestown Water Department

Gallon Tier Structure		Rate per 1,000 Gallons
0	5,000	\$0.00
5,001	9,999	\$7.98
10,000	14,999	\$8.58
15,000	19,999	\$10.87
20,000	49,999	\$15.13
50,000	99,999	\$18.56
100,000	199,999	\$23.76
200,000	999,999,999	\$30.24



Table 12.4
EXCESS SEASONAL WATER RATES

Source: Jamestown Water Department

Minimum	Maximum	Rate per 1,000 Gallons
0	20,000	\$0.00
20,001	49,999	\$15.13
50,000	99,999	\$18.56
100,000	199,999	\$23.76
200,000	999,999,999	\$30.24

The JWD charges a flat fee for each service based on meter size, as shown in Table 12.1, and uses an inclining block rate structure for water use consumption in excess of 5,000 gallons each quarter, as shown in Table 12.2. Table 12.3 depicts the excess seasonal water rates. Water rates are evaluated and adjusted each year relative to the anticipated expenditures and overall water system budget. The current quarterly billing water rates represent a 15% increase from the rates presented in the previous 2015 WSSMP, determined following an evaluation performed by a consultant hired by the Town.

12.5 Billing

Charges for water and sewer service are currently coordinated into a joint bill, mailed quarterly. This method of billing reduces the volume of mail and saves time in the Water Department. While not all customers purchase both services, there have been no issues with this billing method to date.

Funding Requirements

It is important that the JWD establish a reserve fund to prepare for major capital improvements as detailed in Section 11.0. The establishment of a reserve fund will help offset the costs of major capital improvements. A portion of profits and interest within the JWD could be used to develop such a reserve fund.



SECTION 13.0 COORDINATION

13.1 Consistency with Jamestown Comprehensive Plan

The 2015 Jamestown Comprehensive Plan, which was adopted by the Jamestown Planning Commission and Jamestown Town Council on June 18, 2014, was reviewed while updating this WSSMP. This WSSMP is intended to be consistent with the goals and policies of the Comprehensive Plan, and a copy of the WSSMP has been provided to the Jamestown Planning Department for their review. A letter (refer to Appendix I) has been requested from the Jamestown Planning Department confirming consistency between the Comprehensive Plan and this WSSMP.

The Preamble to the Comprehensive Plan identifies that the driving theme of the plan is to promote the protection of the town's rural character. The Comprehensive Plan also indicates that the "Center Island Watershed should continue to be protected. Development should not exceed on-island natural supplies of water. Conservation of existing water supplies should continue to be emphasized, as well as finding new methods to supplement the existing yield."

13.1.1 Land Use

Land within the Center Island Watershed, the watershed to North and South Ponds, is approximately 17% developed and 73% of it is permanently protected. The area is established as a Watershed Conservation District, protected by a RR-200 zoning district and Open Space I District. Land zoned RR-200 limits development to single-family housing on 200,000 square-foot lots. The Open Space I District was established to protect public properties within the Watershed Conservation District. One of the action items identified in the Comprehensive Plan is to "continue to aggressively purchase all vacant properties within the Center Island Watershed" in an effort toward maintaining and improving the Town's public and private water supplies.

The Land Use section of the Comprehensive Plan identifies the challenges associated with the Jamestown Shores area. The area is currently zoned R-40, requiring 40,000 square-foot lots but most lots are much smaller than this, dating back to the original subdivision of 7,200 square-foot lots. Originally, Jamestown Shores was an area of seasonal homes but infill development and expansion of homes into year-round residences has occurred over time.

The Comprehensive Plan reaffirms that the Town does not intend on extending water service to the Jamestown Shores area and identifies that current supply would not be sufficient to sustain service to this area. One significant step that the Town has taken to protect groundwater quality used by individual wells in this area is the creation of an On-Site Wastewater Management Ordinance which requires that all OWTS be inspected and maintained on an established schedule. The Town also created a High Groundwater Table and Impervious Layer Overlay District that encompasses Jamestown Shores, which "regulates impervious coverage on lots as well as storm-water attenuation for new development." Future considerations may include extending public sewer to the Jamestown Shores area to remove the need for OWTS.



The Comprehensive Plan identifies that future land use in Town is becoming more predictable as Jamestown approaches full build-out – less than 15% of the Jamestown remains undeveloped. The Plan recognizes that the most significant issue regarding land use is potable water. It states that:

“Significant improvements to the public water system, the Town’s Wastewater Management Program, and its active land acquisition program have contributed to increasing the public water supply system capacity and protecting the private well-water quality. The Town Council and the Board of Water and Sewer Commissioners should continue to study the future water needs of Jamestown. Jamestown’s growth rate should be managed to insure that the Town’s water capacity is able to adequately supply future population growth.”

13.1.2 Population

The Population component of the Comprehensive Plan indicates that the estimated population in 2000 was 5,622 residents but the population in 2010 decreased to 5,405, according to 2010 U.S. Census estimates. This was a decrease of 217 residents and represents the first instance of declining population after several decades of steady population growth in Jamestown. The JWD estimates that the population currently served by the water system is approximately 3,323 residents.

Population projections made by the RI Division of Planning were most recently revised in 2013 and estimate that the Town’s population will increase at a relatively slow rate in upcoming years, reaching 5,674 residents in 2040. Population projections previously made in 2004 estimated that the population in Jamestown would reach 7,064 residents by 2030. This disparity between past and more recent population growth projections is common in many other parts of Rhode Island and generally the State as a whole.

13.1.3 Natural and Cultural Resources

The Comprehensive Plan identifies several goals that of critical importance to the water system. Specifically, the preamble to the Comprehensive Plan it identifies that “the Center Island Watershed should continue to be protected” and that “development should not exceed on-island natural supplies of water.” It also states that “conservation of existing water supplies should continue to be emphasized, as well as finding new methods to supplement the existing yield.”

The Comprehensive Plan identifies a number of actions that should be implemented to achieve the plan’s policies of maintaining and improving the quantity and quality of public and private drinking water supplies. These actions are as follows:

Policy: Maintain and improve the quality of Jamestown’s public and private water supplies.

- Actions:*
1. Continue to aggressively purchase all vacant properties within the Center Island Watershed.
 2. Continue to update the Emergency Response Plan contained in the Water Supply Management Plan.
 3. Continue to identify potential point and non-point pollution sources.
 4. Reduce pollution on public land and educate private landowners of possible sources of pollution.
 5. Continue to detect leaks and groundwater intrusion in public sewer pipes.



-
6. Implement the recommendations of Ann Veeger’s 1997 University of Rhode Island study.
 7. Conduct studies modeling the Veeger study and adopt an Ordinance that requires retrofitting of cesspools.
 8. Review for amendment Section 308 of the Jamestown Zoning Ordinance to protect development from impacting groundwater resources and other natural resources.
 9. Investigate using best management practices and development plan review for management of the drinking water watershed.

Policy: Protect the quantity of Jamestown’s freshwater resources within the public drinking water watershed and private well areas.

- Actions:*
1. Continue to enforce the 1999 Water Conservation Regulations adopted by Board of Water and Sewer Commissioners and develop stricter penalties for violation and excessive high use rates.
 2. Investigation options to expand the quantity of public drinking water supply system (e.g. desalination, South Pond, increased storage and off-Island sources).
 3. Develop monitoring program that measures effect of pumping Town wells on surrounding wells in the vicinity.
 4. Investigate a reporting and information dissemination system that detects low water levels and salt water intrusion problems in private wells and recommend conservation measures.

13.2 Coordination with Other Water Suppliers

The JWD has a non-permanent emergency interconnection with the Town of North Kingstown, as referenced earlier in this WSSMP. The JWD maintains a close working relationship with the Town of North Kingstown with regard to the maintenance of the emergency interconnection.

13.3 Coordination with Wastewater Collection Systems

Municipal wastewater collection and treatment, in addition to water supply, is provided by the water and sewer division of the town’s Department of Public Works. The Jamestown Town Council sits as the Board of Water and Sewer Commissioners. Joint billing is not currently in place but may be a future consideration in Jamestown.

13.4 Coordination with Local Fire Departments

The Jamestown Fire Department is the sole provider of fire protection service to the town. The JWD coordinates with the fire department to track water usage for fire-fighting and training exercises. The JWD estimates that approximately 100,000 gallons of water is used annually by the fire department.



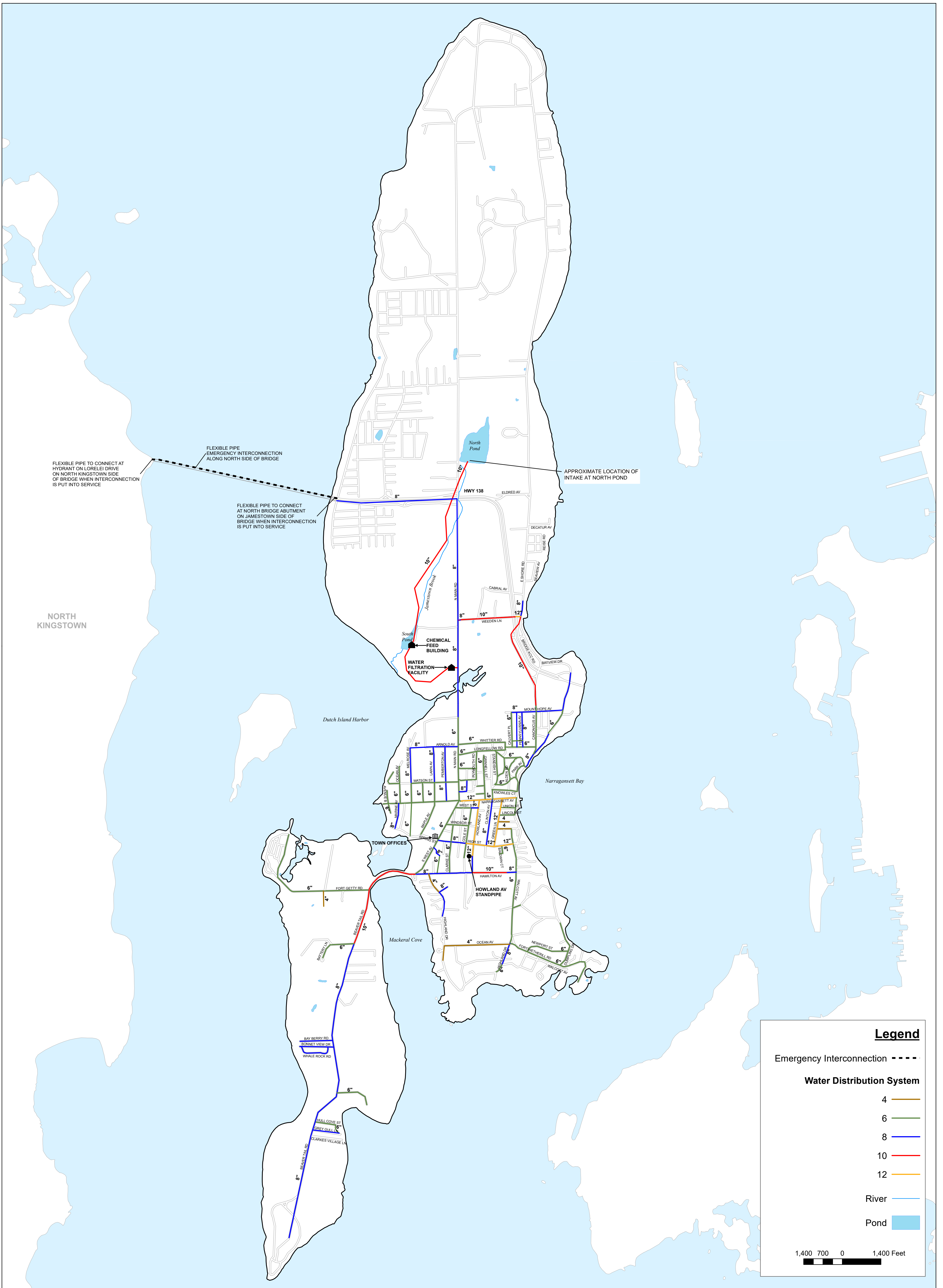

Legend

- Emergency Interconnection - - - - -
- Water Distribution System**
 - 4" - Yellow line
 - 6" - Green line
 - 8" - Blue line
 - 10" - Red line
 - 12" - Orange line
- River - Light blue line
- Pond - Light blue area

1,400 700 0 1,400 Feet

PROJECT NO.: 15050.00
 DATE: JANUARY 2018
 SCALE: 1" = 1,500'
 DESIGNED/DRAWN BY: ANV
 CHECKED BY: SJP
 APPROVED BY: BB
 DRAWING TITLE:
SYSTEM MAP
 DRAWING NO.:
 SHEET NO.: 1 1

SOURCES:
 REVISIONS:



**TOWN OF JAMESTOWN
 WATER SYSTEM
 SYSTEM MAP**

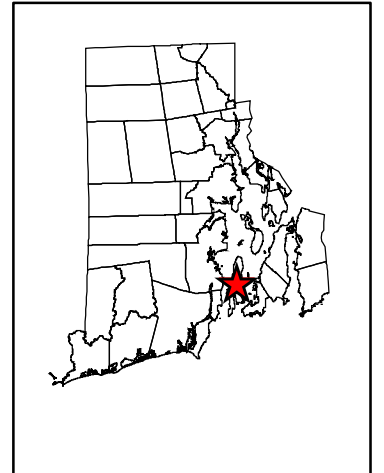
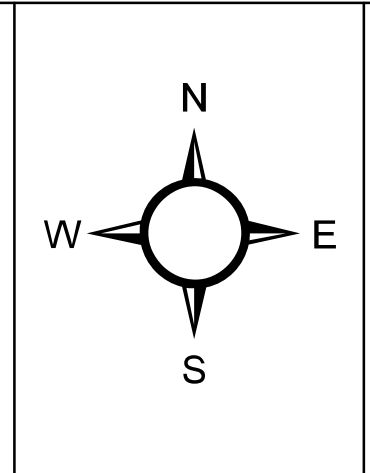

APPENDIX A

Worksheets



WORKSHEET 9 - MAJOR USER INFORMATION (USES GREATER THAN OR EQUAL TO 3 MGY)

Major_User_Name	Major_User_Address	Major_user_primary_use_description	Note
N/A - JWD has no users that use greater than or equal to 3 million gallons per year			

WORKSHEET 11 - CURRENT, 5-YEAR, AND 20-YEAR PROJECTIONS FOR NON-ACCOUNT WATER

Non-Account Type	Current_Year	5_Year	20_Year	Note
Year	2022	2027	2042	
Fire Fighting	100,000	100,000	100,000	
Non-Account Water				
Main Flushing - System Maintenance	100,000	100,000	100,000	
Storm Drain Flushing	5,000	5,000	5,000	
Sewer Cleaning	5,000	5,000	5,000	
Street Cleaning	5,000	5,000	5,000	
Schools and Other Public Buildings				
Landscaping in Public Areas	1,500	1,500	1,500	
Swimming Pools				
Construction Sites				
Water Quality and Other Testing				
Process Water at Treatment Plants	6,050,000	6,050,000	6,050,000	
Leakage	1,000,000	1,000,000	1,000,000	
Leakage, Theft, Meter Error				
Other Unmetered Uses				
Total_NonAccount(Non-Billed)_MG*	7,266,500	7,266,500	7,266,500	
Percent_NonAccount (Total Non-Account / Total Water Produced and Purchased)	11.88	Will Vary Year to Year	Will Vary Year to Year	
*Total Non-Billed Has Remained the Same Since FY 2020 - Future 5-and 20-Year				
Projections Assumes The Same Values Will Continue				

WORKSHEET 15 - CURRENT, 5-YEAR, AND 20-YEAR PROJECTIONS FOR AVAILABLE WATER

condition	Current_Year_MG	5_Year_MG	20_Year_MG	Note
Year	2022	2027	2042	
groundwater_capacity	0.05	0.05	0.05	(2)
surfacewater_operational_safe_yield	0.185	0.185	0.185	(1) (2)
water_purchased	0	0	0	
total_available_water	0.233	0.233	0.233	(3)
average_daily_demand	0.168	0.171	0.175	
max_daily_demand	0.336	0.342	0.350	(4)
(1) Reference Section 5.0 "Available Water" in WSSMP Report				
(2) The 5-and 20-year projections assume that water will be withdrawn from only North Pond and JR-1.				
(3) Total available water is equal to the sum of groundwater capacity + operational safe yield + water purchased from other suppliers. If average daily demand exceeds total available water, identification of additional supply, demand and/or system management measures are to be undertaken and if necessary, the timing and quantity of additional supplies and facilities are to be presented.				
(4) Peaking Factor = MDD / ADD. A Peaking Factor of 2.0 is typically used by JWD. Exceeds safe yield of North Pond and the capacity JR-1 combined.				

WORKSHEET 16 - PAST 3 FISCAL YEARS REVENUE AND EXPENSES

rev_exp_type	Fiscal_Year_1	Fiscal_Year_2	Fiscal_Year_3	Note
Year	2022	2021	2020	
annual_water_rate_revenue				
general_facility_charge_revenue				
special_assessment_revenue				
capital_funds				
reserve_fund_revenue				
other_earned_revenue				
other_unearned_revenue				
total_revenue	\$1,396,314	\$1,343,859	\$1,218,968	
annual_water_system_indebtedness				
debt_service_on_bonds				
operation_maintenance_expenses				
other_expenses				
total_expenses	\$1,104,677	\$1,092,892	\$1,080,257	
Total Income (Loss)	\$291,637	\$250,967	\$138,711	

APPENDIX B

Legislation Establishing Jamestown Water Board



AN ACT
PROVIDING FOR A PUBLIC WATER SUPPLY IN THE
TOWN OF JAMESTOWN.

It is enacted by the General Assembly as follows:

SECTION 1. There is hereby established a board of water commissioners for the town of Jamestown consisting of three qualified electors of the town.

Forthwith after the passage of this act, the town council shall elect three water commissioners, one to serve until March 1, 1969, one until March 1, 1971, and one until March 1, 1973, and thereafter until their successors are elected and qualified. Forthwith after the beginning of each calendar year in which any term expires, the town council shall elect a successor for a term of five years from March 1 of the year in which he is elected and thereafter until his successor is elected and qualified.

The board of water commissioners may act despite a vacancy on the board but, in the event of any vacancy, the town council shall elect a commissioner to serve for the unexpired term and thereafter until his successor is elected and qualified.

Each election or removal by the town council shall be by vote of a majority of the whole number thereof, including vacancies therein.

No employee of the town or holder of any other office of the town shall be eligible to serve as a member of the board of water commissioners.

The town council may require the members of the board of water commissioners to furnish bond for the faithful performance of their duties, in such amounts and with such sureties as the town council may deem desirable. Premiums on surety bonds shall be paid from funds of the board of water commissioners.

No contract shall be made by the board of water commissioners with any member of the board or with the superintendent of the water works system (except his contract of employment) or with any member of their immediate families or with any firm or corporation in which the superintendent or any member of the board, together in either case with the members of his immediate family, owns more than one percent of the total proprietary interest, unless such direct or indirect interest of the member or superintendent is set forth in the minutes of a meeting of the board prior to the making of such contract and the member or superintendent abstains from voting or acting for the district.

as the case may be, in making such contract. A violation of this paragraph shall be grounds for avoiding, rescinding or cancelling the contract on such terms as the interests of the town and innocent third parties may require or for the recovery of damages from any party acting in violation of this paragraph.

Any member of the board may be removed for cause by the town council.

SEC. 2. Forthwith after the election of the original board of water commissioners and after the election of a member upon the expiration of a term, the board shall elect a chairman from among the members of the board and shall elect a secretary, who need not be a member of the board, or designate the town clerk as secretary. The chairman shall preside at meetings of the board and the secretary shall keep the records of the meetings of the board. The board may designate other officers and assistant officers with such Powers and for such terms as the board may determine but the board may at any time remove any such other officers and assistant officers with or without cause, subject to any damages which may be payable for cancellation of a contract with the superintendent as authorized below.

The board shall adopt by-laws or rules for the transaction of its affairs.

SEC. 3. The board of water commissioners may employ and fix the compensation of attorneys, engineers, surveyors, draftsmen, clerks and other employees and agents. The board may elect a superintendent of the water works system and each contract for his services shall not be more than five years. The board may require a surety bond of any of its agents and employees. The premiums shall be paid from funds of the board.

Each of the commissioners shall be compensated for his services at the rate of one hundred dollars per year. The secretary, if not a member of the board or the town clerk acting by designation, shall be compensated at the same rate.

SEC. 4. The board of water commissioners shall be vested with the power and authority to acquire by purchase, subject to approval of a special or annual financial town meeting the assets of the Jamestown Water Company, and thereafter may construct, operate, maintain, extend and improve a water works system for the town and to provide an adequate supply of water for the town or any part thereof. The board is authorized, subject to the approval of the town council, to contract for periods not exceeding forty years with the state, any other municipal or quasi-municipal corporation or with the owners of any privately owned water systems for the purchase or sale of water or for the use of water facilities and the state, such other municipal or quasi-municipal corporations and the owners of privately owned water systems are authorized to enter into such contracts with the board.

oners
wn.
lect
March 1,
rs are
year in
term of
ter until
board
issioner
ected
a majority
n shall be
ommissioners
unts
lums on
ners.
ith any
stem
diate
or any
immediate
, unless
set forth
contract
the district,

Any contract of the board involving more than \$1,000. for construction or for the purchase of materials or equipment, not including contracts for the purchase of water, shall be publicly advertised.

All funds of the board shall be held in the custody of the town treasurer separate from other funds of the town and shall be expended by or under the direction of the board.

In addition to the funds hereinafter provided, the board is authorized to expend for the purposes of this act such sums as may be appropriated therefor by the town.

In carrying out the purposes of this act, the board of water commissioners may lease property or acquire the same by purchase or gift or by eminent domain as hereinafter provided, may make contracts and shall have such further powers as shall be necessary or incidental to the purposes and powers set forth in this act. Any lease, purchase or taking of real property shall be subject to the approval of the town council.

SEC. 5. For the purposes of this act the board of water commissioners may, subject to the approval of the town council, and of a special or annual financial town meeting called for the purpose acquire by eminent domain land or other real property, or any interest, estate or right therein, whether lying within or without the town, including the right to take water from any source.

Without limiting the generality of the foregoing, the board of water commissioners may, subject to the approval of the town council, and of a special or annual financial town meeting called for the purpose acquire by eminent domain all or any part of the real and personal property, or any interest, estate or right therein, belonging to the Jamestown Water Company, including the right of said company to take water from any source.

A taking under this section shall be substantially in the manner and subject to the provisions (so far as apt) set forth in chapter 1 of title 24 of the general laws as heretofore or hereafter amended, provided that a taking under the preceding paragraph shall not require the consent of the division of public utilities.

Whenever the board shall dig up any public street or highway for laying or maintaining pipe, the board shall repair any damage cause thereby to such street or highway.

Any damage which may be agreed upon or determined for any taking under this section, including any interest and other applicable charges, shall constitute a general obligation of the town, but such obligation shall not at any time be included in the debt of the town for the purpose of ascertaining its borrowing capacity for water or other purposes.

SEC. 6. The property acquired and held under this act shall not be subject to taxation or assessment by the town of Jamestown, but not exceeding ten thousand dollars per annum, as determined by the town council, shall be paid from funds of the board of water commissioners to the town in lieu of taxes.

SEC. 7. The board of water commissioners is authorized from time to time to fix water rates for the water furnished by the board, which may be based upon the quantity of water used or the number and kind of water connections made or the number and kind of plumbing fixtures installed on the estate or upon the number or average number of persons residing or working in or otherwise connected therewith or upon any other factor affecting the use of or the value of the water furnished or upon any combination of such factors.

The rates shall be fixed so as to be sufficient to meet the expense of operation and maintenance and the principal and interest coming due on bonds and serial notes issued by the town for the purposes of this act and to provide such reserves as the board may deem necessary to the extent that moneys for the foregoing purposes are not otherwise provided.

Hydrant rentals shall be charged to the town for each year at such rates as the board may determine from time to time. The town shall also be subject to the water rates for other water consumed by the town.

The rates shall be payable upon a date or dates fixed by the board and if not paid within thirty days thereafter they shall bear interest at the rate of eight per cent per annum from their due date until paid.

The board shall cause notice of the amount and due date to be mailed or otherwise sent or given to the owner of the real estate or the tenant or occupant, who shall be personally liable therefor.

A certificate of the collector of taxes of the town stating the amount of any delinquent rate and its due date and the name of the owner of the real estate and the name of the tenant or occupant if assessed to a tenant or occupant who is not the owner and an identification of the real estate shall be filed with the town clerk as a public record, and notice of such filing shall be mailed or sent or otherwise given to such owner. From the date of such filing until the

same is paid in full, such delinquent rate together with any interest and charges accruing thereon shall constitute a lien upon the real estate on a parity with the lien for town taxes.

The collector of taxes shall have the same rights to enforce such liens and to collect the rates and interest and charges thereon as he has in the case of town taxes.

No irregularity in carrying out the provisions of this section shall excuse non-payment of any water rate as long as there is substantial compliance with the provisions hereof and no deficiency in any notice to any party or in any filing with respect to any party shall excuse non-payment by any other party.

In the event a water rate is partially or wholly invalid or unenforceable in any respect, the board may impose a corrected rate to replace the invalid rate or portion or take such other curative action as may be appropriate.

In case of non-payment of any rates or charges or interest thereon with respect to any house, building, tenement or estate, the board of water commissioners is authorized, by its agents and employees, to shut off the water and for this purpose to enter such house, building, tenement or estate, and need not supply water again thereto until the water rates and charges or interest thereon have been paid in full.

SEC. 8. The receipts from water rates, including any net earnings or profits realized from the deposit or investment thereof, shall be deemed appropriated to the board for the purposes set forth in section 4 and for the payment of the principal and interest on obligations incurred by the town for the purposes of this act.

The town treasurer, with the approval of the town council, is authorized to advance moneys to the board of water commissioners from the general funds of the town in amounts not exceeding the sums to be realized from water rates within the next six months as estimated by the board of water commissioners. Such advances shall be repaid without interest from such water rates.

SEC. 9. The town of Jamestown is hereby authorized, in addition to authority previously granted, to issue bonds from time to time under its corporate name and seal or a facsimile of such seal to such amount as will not cause the principal amount of bonds outstanding hereunder to exceed ten per cent of the last assessed valuation of the taxable property of the town. The

currency of the United States of America which at the time of payment is legal tender for public and private debts. The bonds of each issue shall mature in annual installments of principal, the first installment to be not later than three years and the last installment not later than twenty-five years after the date of the bonds. No installment of principal of any issue shall exceed any prior installment by more than six per cent of the total principal amount of the issue.

SEC. 10. The bonds shall be signed by the town treasurer and by the manual or facsimile signature of the president of the town council and shall be issued and sold at not less than par and accrued interest in such amounts as the town council may determine. The manner of sale, denominations, maturities, interest rates and other terms, conditions and details of any bonds or notes issued under this act may be fixed by the resolution of the town council authorizing the issue or by separate resolution of the town council or, to the extent provisions for these matters are not so made, they may be fixed by the officers authorized to sign the bonds or notes. The bonds of each issue shall bear interest at a rate or rates not exceeding six per cent per annum. Coupons shall bear the facsimile signature of the town treasurer. The proceeds derived from the sale of the bonds shall be delivered to the town treasurer, and such proceeds exclusive of premiums and accrued interest shall be expended (a) for the purposes set forth in section 4, excluding current operating and maintenance expenses but including extraordinary repairs, or (b) in payment of the principal of or interest on temporary notes issued under section 11 of this act or (c) in repayment of advances under section 12 of this act. No purchaser of any bonds or notes under this act, however, shall be in any way responsible for the proper application of the proceeds derived from the sale thereof. The proceeds of bonds or notes issued under this act, any applicable federal assistance and the other moneys referred to in this act shall be deemed appropriated for the purposes of this act without further action than that required by this act.

SEC. 11. The town council of the town of Jamestown may authorize the issue from time to time of interest bearing or discounted notes in anticipation of the authorization or issue of bonds under section 10 of this act or in anticipation of the receipt of federal aid for the purposes of this act. The amount of original notes issued in anticipation of bonds may not exceed the amount of bonds voted under section 19 and the amount of original notes issued in anticipation of federal aid may not exceed the amount of available federal aid as estimated by the town treasurer. Temporary notes issued hereunder shall be signed by the town treasurer and by the president of the town council and shall be payable within three years from their respective dates, but the

principal of and interest on notes issued for a shorter period may be renewed or paid from time to time by the issue of other notes hereunder, provided the period from the date of an original note to the maturity of any note issued to renew or pay the same debt or the interest thereon shall not exceed three years.

SEC. 12. The town treasurer, with the approval of the town council, may advance moneys to the board of water commissioners from the general funds of the town in anticipation of the authorization or issue of bonds under section 10 or in anticipation of the receipt of federal aid. Any advances in anticipation of bonds may not exceed the amount of bonds voted under section 19 and any advance in anticipation of federal aid may not exceed the amount of available federal aid as estimated by the town treasurer. In addition, any appropriation by the financial town meeting for the purposes of clause (a) of section 10 shall be treated as an advance under this section if so voted by the financial town meeting. An advance under this section shall be repaid without interest from the proceeds of bonds or notes subsequently issued or from the proceeds of applicable federal assistance or from other available funds.

SEC. 13. Any proceeds of bonds or notes issued hereunder of any applicable federal assistance or of any water rates, pending their expenditure, may be deposited or invested by the town treasurer in demand deposits, time deposits or savings deposits in banks which are members of the Federal Deposit Insurance Corporation or in obligations issued or guaranteed by the United States of America or by any agency or instrumentality thereof or by the State of Rhode Island or as may be provided in any other applicable law of the State of Rhode Island.

SEC. 14. Any accrued interest received upon the sale of bonds or notes hereunder shall be applied to the payment of the first interest due thereon. Any premiums arising from the sale of bonds or notes hereunder, any net earnings or profits realized from the deposit or investment of bond or note proceeds or federal assistance hereunder and any balance of bond or note proceeds or federal assistance hereunder and any balance of bond or note proceeds remaining after completion of the applicable project or projects shall, in the discretion of the town treasurer, be applied to the cost of preparing, issuing and marketing bonds or notes hereunder to the extent not otherwise provided, to the payment of the cost of the project or projects or the cost of other work for which bonds or notes could be issued hereunder, to the payment of the principal of or interest on bonds or notes issued hereunder or to any one or more of the foregoing. The cost of preparing, issuing and marketing bonds or notes hereunder may also, in the discretion of the town treasurer, be met from bond or note proceeds exclusive of premium and accrued interest or from other moneys available therefor. In exercising any discretion under this section, the town treas-

SEC. 15. All bonds and notes issued under this act and the debts evidenced thereby shall be obligatory on the town of Jamestown in the same manner and to the same extent as other debts lawfully contracted by it and shall be excepted from the operation of section 45-12-2 of the general laws. No such obligation shall at any time be included in the debt of the town for the purpose of ascertaining its borrowing capacity under any other law. The town shall annually appropriate a sum sufficient to pay the principal and interest coming due within the year on bonds and notes issued hereunder to the extent that moneys therefor are not otherwise provided. In order to provide such sum in each year and notwithstanding any provision of law to the contrary, all taxable property in the town shall be subject to ad valorem taxation by the town without limitation as to rate or amount, except that the rate of taxation on intangibles shall be limited as provided in section 44-5-6 of the general laws.

SEC. 16. Any bonds or notes issued under the provisions of this act and coupons on any bonds, if properly executed by officers of the town in office on the date of execution, shall be valid and binding according to their terms notwithstanding that before the delivery thereof and payment therefor any or all of such officers shall for any reason have ceased to hold office.

SEC. 17. The town of Jamestown, acting by its board of water commissioners, is authorized to apply for, contract for and expend any federal survey or planning advances or other grants or assistance which may be available for the purposes of this act, and any such expenditures may be in addition to other moneys provided in this act. To the extent of any inconsistency between any law of this state and any applicable federal law or regulation, the latter shall prevail. Federal survey or planning advances, with interest where applicable, whether contracted for prior to or after the effective date of this act, may be repaid as a cost of a project or projects under section 10 of this act.

SEC. 18. In carrying out the purposes and provisions of this act, all steps shall be taken which are necessary to meet constitutional requirements whether or not such steps are required by statute. The validity of bonds and notes issued hereunder shall in no way depend upon the validity or occurrence of any action not specifically required herein for the issue of such bonds or notes.

SEC. 19. Notwithstanding the foregoing provisions of this act, no bonds shall be issued in excess of amounts approved from time to time by vote of a majority of the electors present and voting on the question at an annual or special financial town meeting. A vote not to approve an amount of bonds hereunder shall not preclude any later vote to approve the same or a different amount.

the electors of the town of Jamestown qualified to vote upon a proposition to impose a tax or for the expenditure of money at a special financial town meeting the warning for which shall contain notice of the proposal to accept this act.

SEC. 22. This section and section 21 hereof shall take effect upon passage. The remainder of this act shall take effect upon the approval of this act by a majority of those voting on the question as prescribed in section 21 hereof.

SEC. 23. The board of water commissioners is authorized from time to time to extend and replace the town's water mains, herein called "project", and, regardless of whether the funds for the construction of such project or projects were obtained under this act or under any other general law or special act, the said board of water commissioners shall, to the extent described below, assess the cost of any such project or projects upon the owners of the estates in the town which abut that portion of any street or highway in or along which any water line constituting any portion of such project or projects may be located or which otherwise specially benefit from such project or projects. Such assessments may be made separately for each project or for several projects taken together. The cost to be assessed shall be that which is determined by the board of water commissioners to provide particular rather than general benefit, provided, however, that no such project shall be undertaken until after a public hearing is held thereon. Ten (10) days prior notice of such hearing shall be given by said board to all owners of estates, which abut the project.

Such assessments shall be just and equitable and may be based upon frontage or area within a specified reasonable distance from the street or highway or on assessed valuations or on any other factor affording a reasonable measure of benefits or upon any combination of the foregoing. The board of water commissioners shall not make any particular assessment in excess of the benefit conferred and may make reasonable adjustments of such assessments against estates having a frontage upon more than one street or against estates which for any reason are unable to derive the normal benefits from the water distribution system.

Such assessments shall name the owners assessed, describe their estates and state the amounts of the assessments, but no error or omission in the name or description shall invalidate the assessment as long as either the owner or the estate is substantially identified.

A copy of such assessments shall be recorded with the collector of taxes as a public record. From the date of delivery to the collector of taxes the assessments and interest accruing thereon shall constitute a lien upon the respective estates on a parity with the lien for town taxes until paid in full. The collector of taxes of the town shall have the same rights to enforce such liens against the estates and to collect such assessments and interest from the owners as he has in the case of town taxes.

Prior to or forthwith after the delivery to the collector of taxes of a copy of such assessment he shall cause notice to be sent to the owner of each estate assessed. The notice shall substantially identify the estate assessed, state the amount of the assessment and refer to the remedy available under this section. The notice shall be mailed postpaid and directed to the last known address of the addressee. If there are owners whose addresses are unknown, a similar notice covering the assessments against their estates shall be published in a newspaper of general circulation in the town and such published notice may be a single collective notice for all such owners. No irregularity in the notice required by this section shall excuse the non-payment of the assessment or affect its validity or any proceedings for the collection thereof as long as there is substantial compliance with the provisions hereof. No deficiency in the notice to the owner of an estate assessed shall excuse the non-payment by others of the assessments against their estates or affect the validity thereof or any proceedings for the collection thereof.

Any person aggrieved by any such assessment may within 90 days after the mailing or publication of notice to him file a petition for relief against the town as respondent in the superior court, and the clerk shall thereupon issue a citation to summon the town, and said petition and citation shall be subject to the provisions of section 44-5-29 of the general laws. If the court finds such assessment invalid in whole or in part, it shall give judgment reducing the amount thereof or for a refund accordingly. The filing of such a petition shall not relieve the estate involved from the lien hereinabove provided for or prevent the assessment becoming due as provided in this section, but the final judgment of the court reducing such assessment in whole or in part shall reduce such lien and the amount due accordingly. The remedy provided in this paragraph shall be exclusive, and no action or proceeding questioning the validity of any such assessment shall be begun after the expiration of said 90-day period.

In the event an assessment is partially or wholly invalid the board of water commissioners may make a corrected assessment to replace the invalid assessment or portion. The corrected assessment shall be made in the same manner as an original assessment. The first installment of a corrected assess-

which would have become due then or theretofore if the corrected assessment had been made at the time of the original assessment. The corrected assessment shall bear interest from the date notice of the corrected assessment was delivered to the collector of taxes.

Except as provided in the preceding paragraph, each assessment under this act shall be payable in not less than ten nor more than twenty equal annual installments. The board of water commissioners by resolution may, from time to time, determine the number of annual installments in which assessments thereafter made under this act shall be paid, but in the absence of any such resolution the number of such installments shall be ten. The unpaid balance of each assessment shall bear interest from the date a copy of the assessment was delivered to the collector of taxes until the assessment is paid in full. The rate of interest shall be determined by the board of water commissioners prior to or forthwith after the delivery of the copy of the assessment to the collector of taxes. If any part of the project or projects with respect to which the assessment was made was permanently financed by borrowing, such rate shall, to the nearest higher one tenth of one per cent, be equal to the actual rate of interest paid by the town with respect to funds borrowed by it to finance such project or projects. The annual payments of each assessment, with the appropriate amount of interest then payable, shall become due commencing with the date on which the regular town taxes are due and payable which next follows the date on which a copy of the assessment was delivered to the collector of taxes, provided that the whole assessment against any owner or estate may be paid without interest at any time prior to the due date of the first installment thereof, and provided further that the whole unpaid balance of any such assessment together with the interest accrued thereon to the date of payment may be paid at any time.

In the event of the subdivision of any estate subject to any such assessment by the conveyance of any part or parts thereof to a different owner, the board of water commissioners may apportion the assessment or the unpaid part thereof among the new estates so created upon any basis which might then be used under this section for a new assessment and such basis need not be the same as that used for the assessment being apportioned. The apportioned assessments shall be payable at the same times and in the same amounts pro rata as the original assessment or unpaid part thereof. In all other respects the apportioned assessments shall be governed by the provisions of this section which would then apply to a new assessment. Upon the recording of the apportioned assessments, the original assessment shall be discharged.

SEC. 24. The receipts from the assessments provided for in section 23 of this act shall be kept in a separate fund and shall be used as directed by the board of water commissioners (a) for the construction, operation and maintenance of water distribution facilities, or (b) for the repayment of advances made under section 12 of this act, or (c) for the payment of bonds or notes issued under this act or issued under any other general law or special act to finance the construction of water distribution facilities. The foregoing provisions shall not be construed as a limitation upon the power and duty of said town to appropriate and raise in the regular town tax such amounts as may be necessary for the prompt payment of principal and interest maturing upon all outstanding bonds or notes issued under this act or under any other general law or special act.

SEC. 25. In the event that the town has not authorized sufficient borrowing or provided sufficient other funds to undertake a requested extension, or the board of water commissioners determines that higher priority exists for the use of the proceeds of borrowing or other funds, the board of water commissioners may, in lieu of levying all or part of an assessment under this act, require the person or persons requesting such extension to contribute all or part of the cost thereof before the project is commenced.

APPENDIX C

North Kingstown – Jamestown Emergency Supply Agreement





INCORPORATED 1674

TOWN OF
NORTH KINGSTOWN, RHODE ISLAND

DEPARTMENT OF WATER SUPPLY
401-294-3331 EXT. 231

80 BOSTON NECK ROAD
NORTH KINGSTOWN, RI 02852

MEMORANDUM

24 August, 1999

TO: PUMP STATION OPERATORS
FR: Michael Martin, Water Director *ma*
RE: Water Supply to Jamestown

North Kingstown has approved a temporary reactivation of the Jamestown emergency connection. The following guidelines should be applied:

1. The North Kingstown Pump Station Operator on duty is the control authority.
2. The amount and duration of supply to Jamestown Island is at their discretion.
3. The operator on duty will use their judgement in regards to what wells to place on line, how the PRV is to be utilized, safe tower levels etc.
4. The operator on duty is authorized to work overtime including, staying over, coming in early, and/or calling for additional assistance if necessary.
5. The operator on duty will maintain a record of usage and any overtime costs needed to accomplish the task. Jamestown has agreed to reimburse North Kingstown for those expenses.
6. If, in the judgement of the North Kingstown operator on duty, there is a need to terminate the service to Jamestown, the operator is to provide Jamestown with 30-minute notice prior to shutting off the supply. Supply may be resumed upon coordination with Jamestown.
7. The operator on duty will communicate as necessary with the Jamestown operators using the call list below:
 - Water Plant 423-7291
 - Plant Pager 938-0790
 - Peter Home 294-2355
 - Rich Home 933-6291
 - Bill Home 938-8143
8. The North Kingstown operators can be reached between 7am and 11pm, seven days a week by calling:
 - Pump Station 294-3331 ext. 235
 - Pager (leave return number) 452-5625
9. Jamestown and North Kingstown Directors can be reached at:
 - Steve Cell Phone & Answering Machine 742-0170
 - Mike Martin Home 508 295-7173 Pager 938-9165

cc: Town Mgr.
RIDOH
Jamestown DPW

MICHAEL A. MARTIN, DIRECTOR

JOAN H. RAYMOND, OFFICE MANAGER

APPENDIX D

FS&T Safe Yield Report (October 2000)



FAY, SPOFFORD & THORNDIKE, INC.
ENGINEERS • PLANNERS • SCIENTISTS

**TOWN OF JAMESTOWN
RHODE ISLAND**

SAFE YIELD ANALYSIS

Fay, Spofford & Thorndike, Inc.
Burlington, MA

October, 2000



FAY, SPOFFORD & THORNDIKE, INC.

ENGINEERS • PLANNERS • SCIENTISTS

5 BURLINGTON WOODS • BURLINGTON, MASSACHUSETTS 01803
TEL (781) 221-1000 • (800) 835-8666 • FAX (781) 229-1115

DIRECTORS
ROBERT J. CATON
EMILE J. HAMWEY
JAMES G. ROURKE
WILLIAM J. GLOVER, JR.
EDWARD A. WELCH
ROBERT A. BENSON
ROBERT E. BERTOLINO
DEAN L. GROVES
STEVEN R. WHITE
THOMAS D. JENKINS
MICHAEL A. ROACHE
FRANK A. TRAMONTOZZI

October 6, 2000

Mr. Steve Goslee
Public Works Director
Town of Jamestown
P.O.Box 377
Jamestown, RI 02835

Subject: **Final Report**
Safe Yield Study - North and South Ponds

Dear Mr. Goslee:

FAY, SPOFFORD & THORNDIKE, INC. (FST) is pleased to submit twenty (20) copies of the Final Report on the Safe Yield Study for North and South Ponds. The findings of the study indicate that the total yield of North and South Pond is about 285,000 gpd without transfer pumping and about 400,000 gpd with transfer pumping.

If you have any questions, please do not hesitate to call.

Sincerely,

Fay, Spofford & Thorndike, Inc.
By,

Christopher C. Yamoni, P.E.
Associate

CCY:ccy
WJ-001
Enclosures

TABLE OF CONTENTS

Page

I.	Background	1
II.	Previous Safe Yield Estimates	2
III.	Purpose	3
IV.	System Description	4
V.	Safe Yield Analysis	8
	A. General Method	8
	B. Safe Yield Model Development	8
	C. Model Simulation and Validation	8
	D. Safe Yield Evaluations	20

LIST OF TABLES

1	Water Supply Requirements (gpd)	1
2	Previous Safe Yield Estimates (gpd)	2
3	Water Supply Information	6
4	Variable Monthly Surface Water Inflow Factors	10
5	Surface Water Inflow Factor Comparisons - South Pond	19
6	Monthly Demand (MG)	20
7	Safe Yield (gpd)	21
8	Safe Yield with Transfer Pumping (gpd)	23

LIST OF FIGURES

1	Water Supply and Treatment Facilities Location Plan	5
2	Jamestown Water Supply System Schematic	7
3	Annual Rainfall - Conanicut Island	13
4	North Pond Simulation (1963 - 1967)	15
5	North Pond Simulation (1980 - 1982)	16
6	North Pond Simulation (1987 - 1991)	17
7	North Pond Simulation (1997 - 1999)	18
8	Safe Yield w/o Transfer Pumping	22
9	Calculated Overflow for North Pond and South Pond (1997-1999)	25
10	Safe Yield with Transfer Pumping	26
11	Safe Yield with Transfer Pumping w/o South Pond	27

LIST OF APPENDICES

- A - Summary Report on Safe Yield (1982)
- B - Water Level/Storage Capacity North Pond
- C - Computer Model Simulation
- D - Safe Yield Output Files
- E - Safe Yield with Transfer Pumping Output Files
- F - Safe Yield with Transfer Pumping w/o South Pond Output Files

I. Background

Periodically over the last decade, the available water supply from North Pond has not been able to satisfy the water demand requirements of the Town. The impact of an increase in the number of customers coupled with a lack of rainfall during the summer months has resulted in the water demand exceeding the available water supply from North Pond. The shortage of water supply required the Town to install an emergency connection to North Kingstown in 1993.

An additional source of supply is South Pond. However, the highly colored water from this source can not be reduced to levels that are considered acceptable from an aesthetic standpoint by the existing treatment plant when using South Pond water alone. This year, the Town has been blending water from South Pond with water from North Pond in the raw water pipeline from North Pond. The Town is also supplementing the water supplied from the North Pond and South Pond surface supplies with groundwater.

The current population of the Town is about 6,000 people, 3,100 of which receive water from the municipal water supply system. The 1999 average day demand (water pumped into the distribution system from the water treatment plant) of the Town was about 215,500 gallons per day (gpd) or 150 gallons per minute (gpm). However, the actual water needed from the supply must also include the water utilized for flushing and backwashing the water treatment processes which constitutes an additional 15 percent or about 32,326 gpd for a total current water supply requirement of about 247,800 gpd. Current and future average day water supply withdrawal requirements are summarized in Table 1.

Table 1: Water Supply Requirements (gpd)

Time Period	Water Supply Withdrawal
1999	247,800
2005	248,400
2020	285,000

II. Previous Safe Yield Estimates

General water supply guidelines require that the average daily withdrawal from a reservoir system not exceed the safe yield. In March 1982, Richard Hazen completed a Summary Report on the Jamestown Water System, which included estimating the safe yield from North Pond for 50 (98% dry) and 10 (90% dry), -year recurrence intervals as summarized in Table 2. The portion of this Report relative to the safe yield is attached as Appendix A. The estimated safe yield from South Pond for the 50-year recurrence interval from the 1994 Water Supply Management Plan is also summarized in Table 2.

Table 2: Previous Safe Yield Estimates (gpd)

Recurrence Interval (years)	North Pond	South Pond
50	150,000	25,000
10	200,000	—

A 50-year recurrence interval may be defined as the second driest year in a one hundred year period of record and a 10-year recurrence interval may be defined as the tenth driest year in a one hundred year period of record. Therefore, a 50-year recurrence interval means that there is a 98% probability that the estimated yield will not be exceeded.

The NEWWA procedure for estimating the storage required to meet the record breaking drought that occurred between 1961 and 1967 was used to estimate the 98% safe yield of 150,000 gpd at North Pond. This procedure develops tables and graphs of safe yield and storage required stated per square mile of watershed area and is based upon drainage area; percentage of drainage area covered by the reservoir; rainfall and evaporation; and streamflow for a particular watershed where this type of information is available.

There is no historical streamflow information from the Jamestown Brook watershed other than several values measured during a URI study conducted in 1995. Therefore, historical stream gage data from the Abbott Run watershed (27 sq. mi.) and the Scituate watershed (93 sq. mi.) during the record breaking drought were used to estimate the yield available based upon the available

storage at North Pond. Applying data developed from the Scituate studies and Abbott Run studies to the much smaller North Pond watershed of 0.3 sq. mi. resulted in an estimated 98% safe yield of 200,000 gpd based upon the Scituate study and an estimated 150,000 gpd based upon the Abbott Run study. The more conservative 150,000 gpd was selected as the 98% safe yield for North Pond.

III. Purpose

The current water withdrawal requirement of about 248,000 gpd is well above the previously estimated 98% safe yield and even higher than the estimated 90% safe yield of North Pond. It is not surprising that the Town has had difficulty meeting water withdrawal requirements several times over the last ten years, especially considering that South Pond has not been utilized on a regular basis.

Options to increasing available water supply, discussed in the 1999 Water Treatment Feasibility Study, included blending water from South Pond in the raw water pipeline receiving water from North Pond, supplementing surface water supply with groundwater supply and/or transferring water from South Pond to North Pond.

As part of the Limnological Study completed in 1999, a safe yield study of North Pond and South Pond was recommended to verify the proper transfer rate, to determine the impact of increasing the North Pond reservoir level, and to be utilized as a tool to develop an operating scheme for the wells and reservoirs to maximize water quantity.

IV. System Description

The Town utilizes two surface water supplies, North and South Pond, as well as one bedrock well located south of North Pond. Each of these sources of supply is located within the 651 acre oval shaped Jamestown Brook Watershed presented as Figure 1.

North Pond (Carr Pond) Reservoir was originally constructed in 1900 (Jamestown Water Study Committee, 1994) and is located in the upper reaches of the watershed north of Route 138. It has a drainage area of 192 acres (0.3 sq. mi.) and a useable storage capacity of about 60 million gallons based upon DEM calculations from a previous bathymetric survey. North Pond has been reported to have a 98% safe yield of 150,000 gpd, respectively. It is about 15 feet deep and has a spillway overflow elevation of 37 feet mean sea level (MSL). Overflow from North Pond travels down Jamestown Brook into South Pond. Water is withdrawn by gravity from North Pond through about 10,000 feet of 10-inch PVC and transite (AC) pipe to the water treatment plant (WTP) located on North Road north of Great Creek for treatment and pumping into the distribution system.

South Pond (Watson Pond) is located in the lower part of the watershed approximately 7,000 feet south of North Pond. It has a much larger drainage area of 449 acres (0.7 sq. mi.) but a much smaller useable storage capacity of about 8 million gallons. South Pond has been reported to have a 98% safe yield of 25,000 gpd. It is about 11 feet deep and has a spillway overflow elevation of 16.3 feet MSL. South Pond overflows into Dutch Island Harbor. Table 3 presents general data on North and South Ponds. Water may be withdrawn by gravity from South Pond through the last 2,600 feet of 10-inch transite pipe from North Pond as long as flow from North Pond is shutdown. Water may also be pumped into the 10-inch transite pipe from South Pond which allows for blending with water flowing by gravity from North Pond.

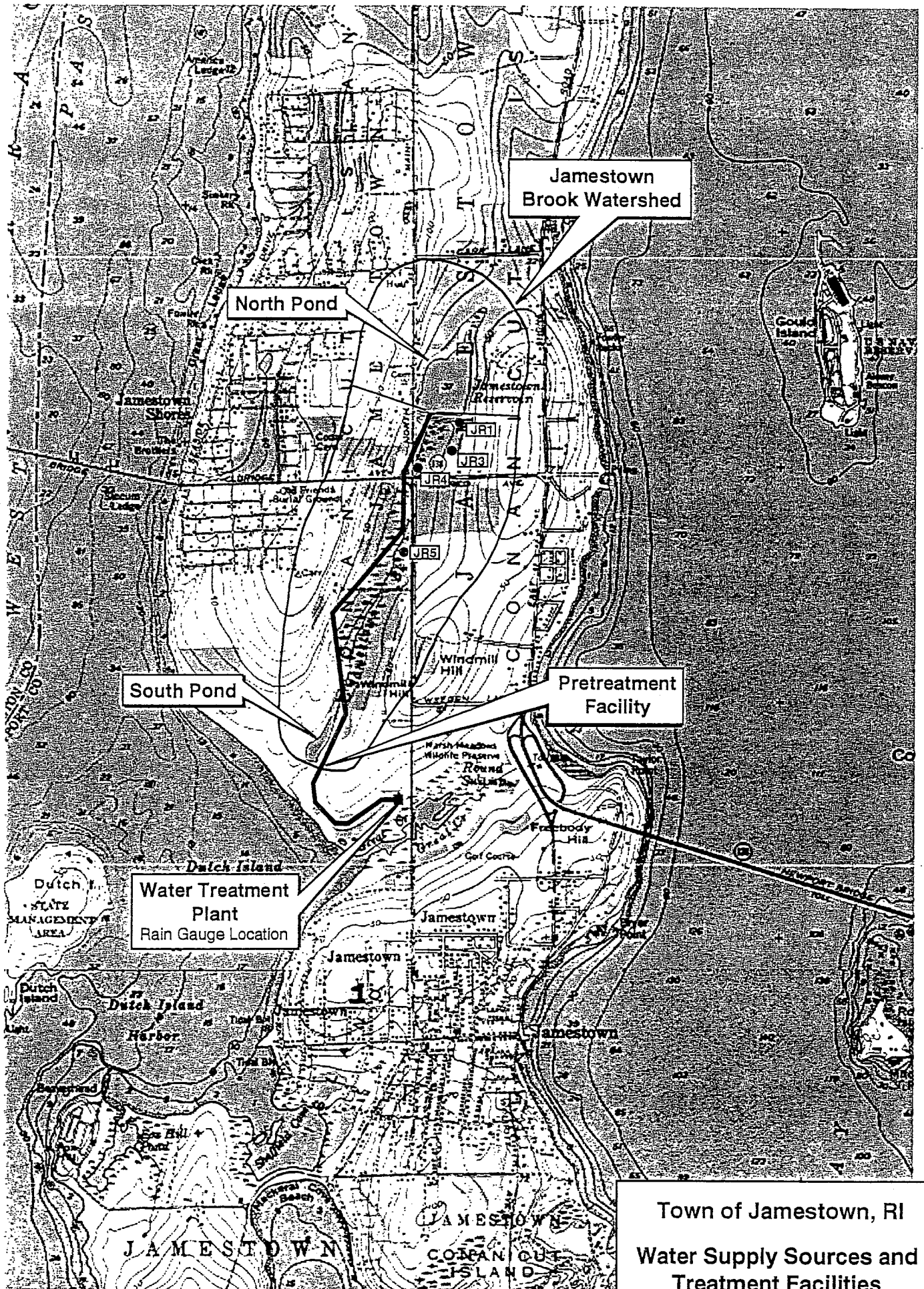

Town of Jamestown, RI
 Water Supply Sources and
 Treatment Facilities
 Figure 1

TABLE 3: Water Supply Information

Source	Watershed Area		Total Volume	Total Depth	Useable Volume	Useable Depth	Surface Area	Spillway Crest El.
	(acres)	(sq. mi.)	(MG)	(feet)	(MG)	(feet)	(acres)	(feet)
North Pond	192	0.3	67	15	60	10	25.4	37
South Pond	449	0.7	10	11	8	7*	4.67	16.3
Total	641	1	77		68		30.07	53.3

* assumed value

The watershed areas in Table 1 were calculated using Rhode Island Geographical Information Systems (RIGIS). A copy of the water level/storage capacity data developed from the bathymetric survey of North Pond is presented as Appendix B. A schematic of the Jamestown Water Supply System is presented in Figure 2

Since 1996, three (3) bedrock wells (JR-1, JR-3 and JR-4) 225 to 345 feet deep with capacities ranging from 45,000 to 55,000 gpd have been installed south of North Pond and north of Route 138 to augment the surface water supply. Due to wetland impacts, JR-1 or JR-3 may be utilized, one at a time.

JAMESTOWN WATER SUPPLY SYSTEM

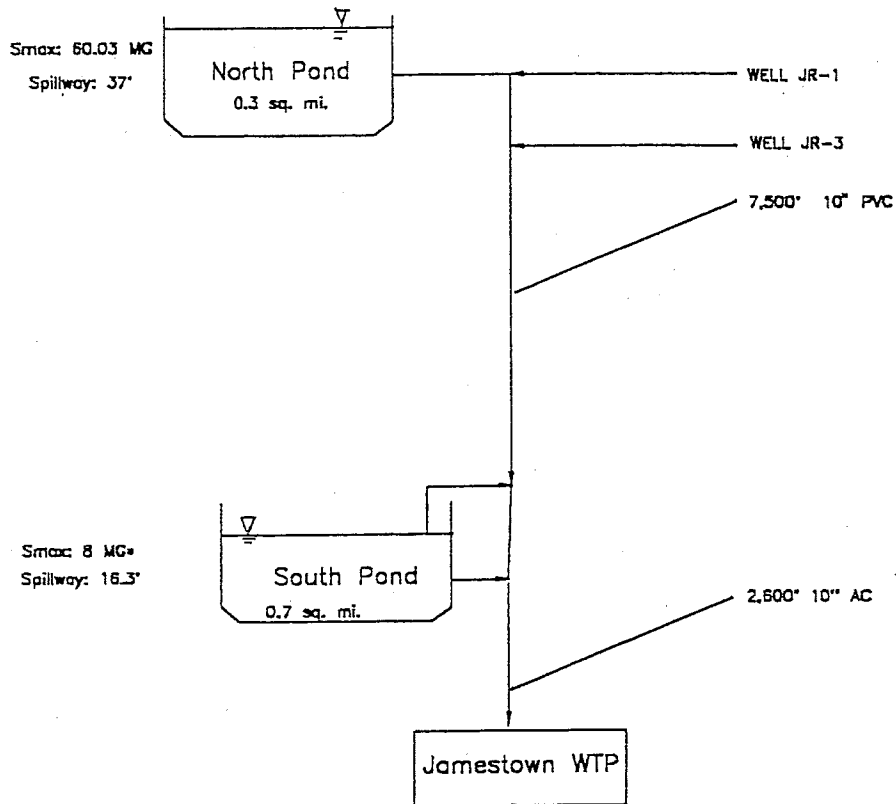

FIGURE 2

SCHEMATIC OF
JAMESTOWN WATER SUPPLY SYSTEM

TOWN OF JAMESTOWN
RHODE ISLAND

PVC - Polyvinyl Chloride
sq. mi. - square miles
MG - Million Gallons
Smax - Maximum Useable Storage

V. Safe Yield Analysis

A. General Method

The safe yield of the reservoir system was defined as the annual average daily withdrawal rate which results from:

- the maximum depletion of all useable storage capacity at least once during the 40 year period of simulation between 1960 and 1999.

B. Safe Yield Model Development

FST created a computer model to simulate the Town of Jamestown's water supply system and compute the safe yield. The safe yield is influenced by a number of hydrologic and hydraulic factors, including watershed area, local rainfall-runoff relationships, reservoir storage capacity, and system losses. In multi-reservoir systems such as the Town's, system operation and management also affect the safe yield. The simulation model incorporates these factors and performs mass balance computations ($\text{INFLOW} - \text{OUTFLOW} = \text{CHANGE IN STORAGE}$) for North Pond or South Pond on a monthly basis, to simulate system responses to water withdrawal rates. Key inputs to the model that characterized the water supply system included:

- precipitation on reservoir (pond)*
- direct runoff (surface water inflow)
- reservoir evaporation
- demand withdrawal rates
- inter-reservoir transfers

* The term "reservoir" and "pond" is considered one in the same and was utilized throughout the text and in the computer model outputs included in the Appendix.

C. Model Simulation and Validation

Model simulation and validation runs were completed for North Pond. Inflows to the reservoir system consisted of precipitation on the reservoir surface, and surface water inflow from the watershed drainage area. Outflows included evaporation, demand withdrawals and overflow spillage. A variable monthly runoff factor was utilized to estimate the surface water inflow.

1. Inflows and Outflows

Reservoir Rainfall

The volume of rainfall precipitating directly on the surface of the reservoir was calculated by multiplying the precipitation converted to feet by the reservoir surface area in square feet and then converting to million gallons. Precipitation data for model simulation and validation from 1963-1967, 1980-1982, 1987-1991, and 1997-1999 was provided by the Town. This information was collected at a rain gauge at the WTP.

The monthly reservoir surface area was adjusted each month to account for changes due to fluctuating water elevations and variable bathymetry. The estimated volume of water in the reservoir calculated in the previous month was used to look up the corresponding surface area from the "lookup" table of bathymetric data. The water level/storage capacity data from North Pond attached as Appendix B was entered into a tabulation where the surface area was calculated for each million gallons of storage.

Surface Water Inflow (Run-off)

Surface water inflow is the amount of water entering the reservoir from rainfall on the drainage area. Not all of the precipitation that falls on the drainage area enters the reservoir. The amount of water entering the reservoir from rainfall on the drainage area around the reservoir is dependent upon the time of year which affects losses from evapo-transpiration and from water entering the ground. In March and April the percent of surface water inflow entering the reservoir is high due to snow melt and in August and September is low due to high rates of evapo-transpiration and depletion of groundwater storage.

A surface water inflow was calculated by multiplying the total volume of water resulting from rainfall on the drainage area by a variable monthly surface water inflow factor to account for the monthly changes in surface water inflow which typically occur throughout the year. The total volume of water resulting from rainfall on the drainage area was determined by multiplying the

precipitation in feet by the drainage area adjusted each month (total watershed area minus the monthly adjusted reservoir surface area).

The variable monthly surface water inflow factor was estimated for each month of the 40 year period of record from the Parker River watershed in MA. It equals the total amount of run-off from rainfall on the watershed for that month divided by the streamflow at the watershed's gauging station for that month. An average surface water inflow factor was then calculated for each calendar month. For example, the inflow factor of 0.63 for January from the Parker River data equals the average factor of the 40 January's in the period of record and is 118% of the average surface water inflow factor (1.18 x 0.53).

TABLE 4: Variable Monthly Surface Water Inflow Factors

Source	Hubbard Brook	Nepaug River	Parker River	Percent of Average Inflow Factor
January	0.59	0.62	0.63	118
February	0.50	0.56	0.73	138
March	1.17	1.24	1.17	220
April	1.64	1.09	1.13	213
May	0.63	0.59	0.76	143
June	0.38	0.35	0.43	80
July	0.18	0.23	0.14	26
August	0.16	0.22	0.09	17
September	0.06	0.10	0.08	15
October	0.17	0.21	0.26	49
November	0.39	0.33	0.35	66
December	0.45	0.42	0.55	104
Average	0.53	0.50	0.53	100

Table 4 presents variable monthly surface water inflow factors for several watersheds in New England including the Parker River, the Hubbard Brook (19.9 sq. mi.) and the Nepaug River (22.7 sq. mi.) in CT. The percent of the average surface water inflow factor for the period of 1960 to 1998 for the Parker River is also presented.

Table 4 indicates that for the 21.3 sq. mi. Parker River watershed about 53 percent of the water that falls from precipitation ends up in the river on average. This is equivalent to about 1.09 million gallons per day (MGD) per square mile, very close to the 1.16 to 1.29 MGD/sq. mi. reported in the 1982 Summary Report for the average annual run-off from six streams within 30 miles of Jamestown.

To account for differences between the Parker River watershed's monthly runoff factors and Jamestown's, the average runoff factor of 0.53 for the Parker River was adjusted by trial and error until the North Pond water level predicted by the computer model matched actual pond level measured over the last 40 years. This is explained further in the results section of this report.

Evaporation

Evaporation losses depend on seasonal climatic conditions and reservoir surface area. The reservoir surface area was adjusted on a monthly basis depending upon the volume in the reservoir in the previous month as described previously. The model computed evaporation loss at each reservoir by using the equation provided in *Estimating the Firm Yield of a Surface Water Reservoir Supply System in Massachusetts A Guidance Document*. Utilizing monthly temperature data from Jamestown, the equation computed the monthly reservoir evaporation rate, in mm/day, which was converted to feet/month, then multiplied by the reservoir surface area to obtain a monthly evaporation volume in cubic feet and finally converted to MG.

Spillage

Losses from spillage or overflow over the crest of the spillway are the last quantities that the model computes in a given time step. Spillage only occurs when the reservoir storage is at capacity. It was assumed that 90% of the overflow from North Pond entered South Pond by way of Jamestown Brook to account for evaporation and other potential losses.

2. Results

FST calibrated the model to known conditions. Fortunately, monthly reservoir operating levels for North Pond have been recorded on a monthly basis at the water treatment plant by the Town over the last forty years. There is no historical information on reservoir operating levels at South Pond since South Pond has not typically been utilized due to the poor water quality. Therefore, as a first step, North Pond historical reservoir operating levels were utilized to calibrate the computer model. The model was run for three, 3 to 4 year time periods over the last forty years for which known rainfall, demand withdrawals, temperature and reservoir water volume were available namely; 1963-1967, 1980 -1982, 1987-1991, and 1997-1999 for North Pond.

The annual rainfall for these four periods ranged from a low of 27.7-inches in 1980 to a high of 53.6-inches in 1988 as compared to the 40-year average annual rainfall of 43.5-inches. These are the lowest and second highest rainfall years in the last 40 years. Calibrating the computer model for periods of low and high rainfall results in a model that is able to more accurately simulate extreme conditions. Annual rainfall on Conanicut Island for the last 40 years is presented on Figure 3.

A total monthly run-off (surface water inflow) was calculated by multiplying the volume of water resulting from rainfall on the watershed drainage area by the variable monthly surface water inflow factors from the Parker River watershed presented previously in Table 4.

In order to determine the average surface water inflow factor for North Pond watershed, an initial factor of 0.53 from the Parker River watershed was selected and the model computed the change in storage on a monthly basis by adding the inflows of precipitation, surface water inflow and subtracting the outflows of evaporation, and demand withdrawals. The change in storage for the month was added to the previous months storage and then the process was repeated in the next month.

Precipitation

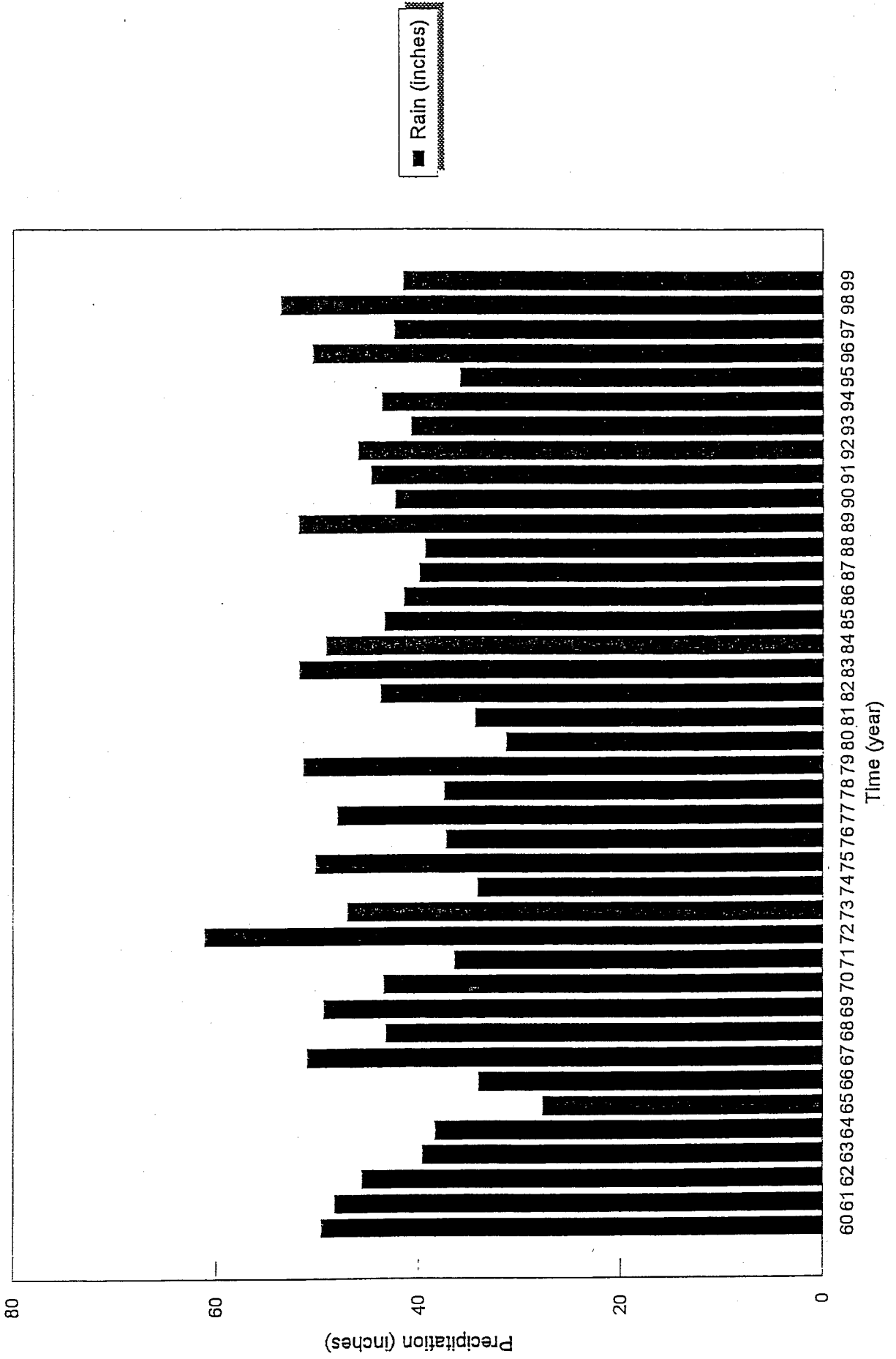

The simulated reservoir end-of-month storage volume through the four simulation periods between 1960 and 1999 were compared to the actual storage volumes for these periods. The average monthly surface water inflow factor was adjusted until monthly simulated storage volumes matched historical recorded monthly storage volumes of the reservoirs for model validation. Figure's 4, 5, 6 and 7 are time history graphs of recorded versus simulated reservoir capacity in million gallons for the four simulation periods.

The simulated reservoir capacity from the computer model is presented at three different average surface water inflow factors for each simulation period namely, 0.40, 0.50 and 0.60. This shows the sensitivity of the computer model as a result of changing the average surface water inflow factor. Examination of the three periods indicates that an average surface water inflow factor of 0.45 provides the closest simulation of actual reservoir volumes recorded at North Pond. In other words, on average, about 45 percent of the rain that fell on the 192 acre drainage area around North Pond ended up in North Pond.

In general, the simulation utilizing the 0.45 average surface water inflow factor shows a good match to the historic data; therefore, the methodology for computing surface water inflow into the reservoirs, based on the variable monthly surface water inflow factors was considered valid and utilized in the safe yield evaluation. Tabulations summarizing the input and output data as well as the 3 1/2-inch diskette of the computer model simulation are attached as Appendix C.

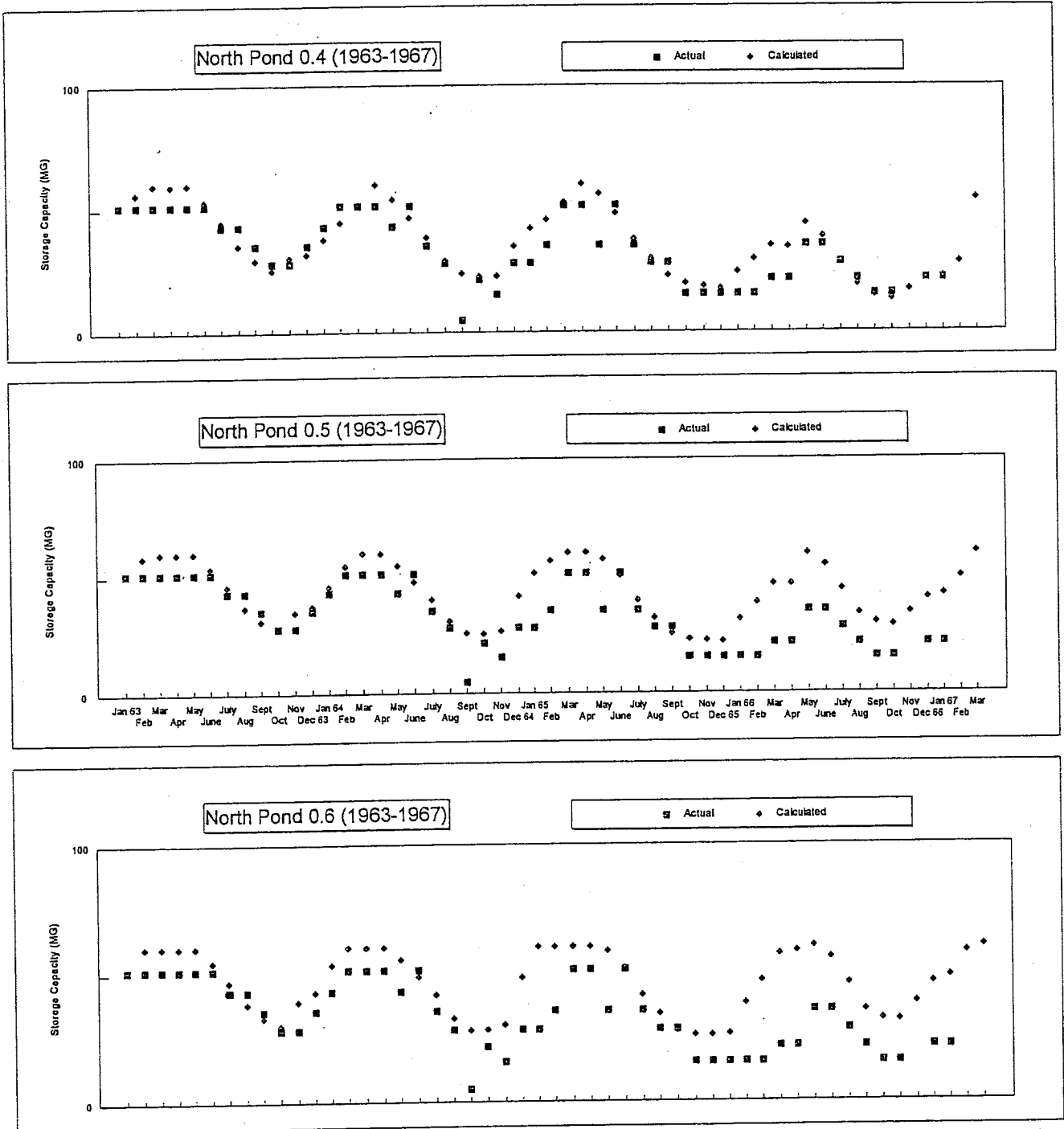

Figure 4 - North Pond Simulation (1963 - 1967)

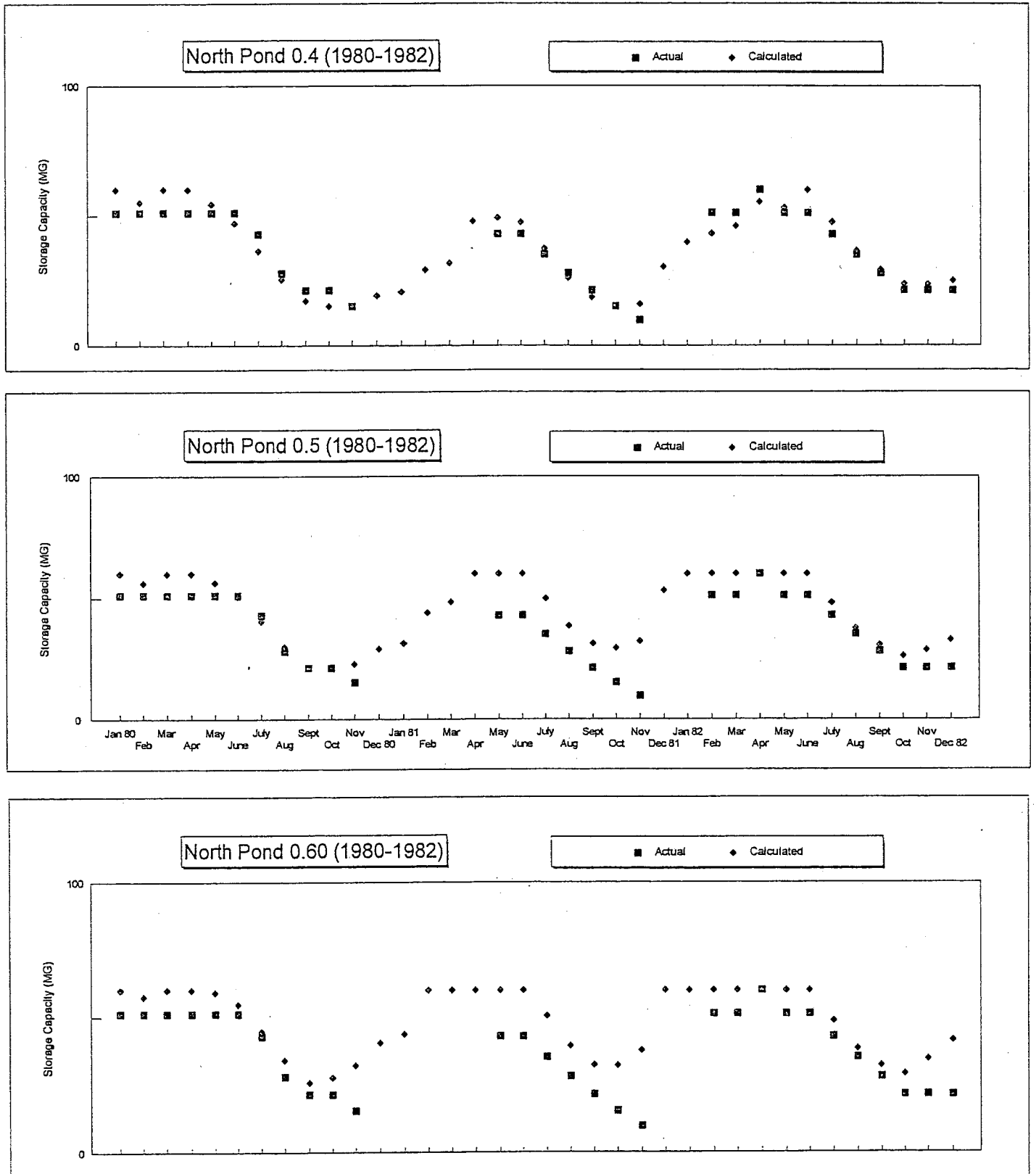

Figure 5 - North Pond Simulation (1980 - 1982)

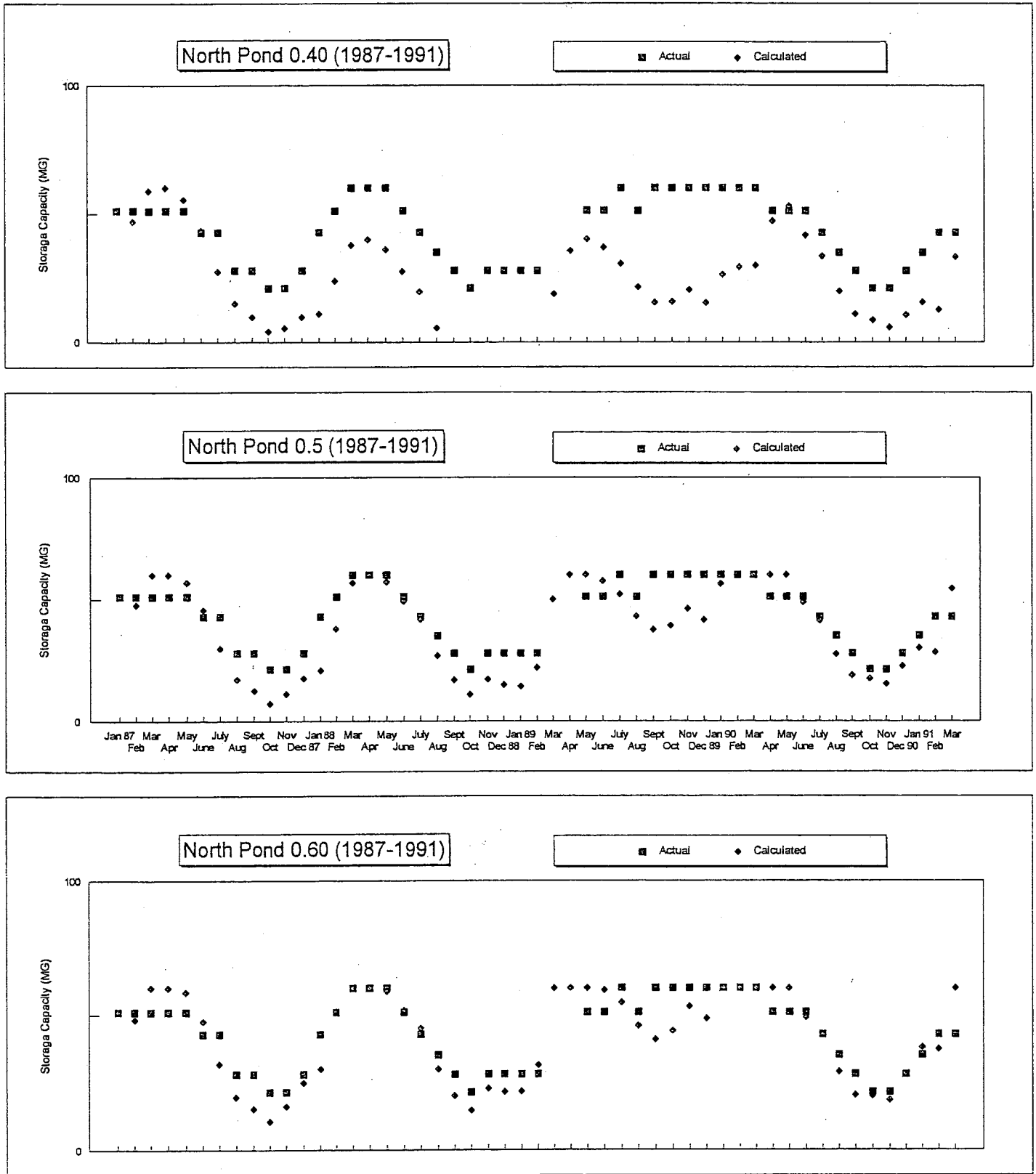

Figure 6 - North Pond Simulation (1987 - 1991)

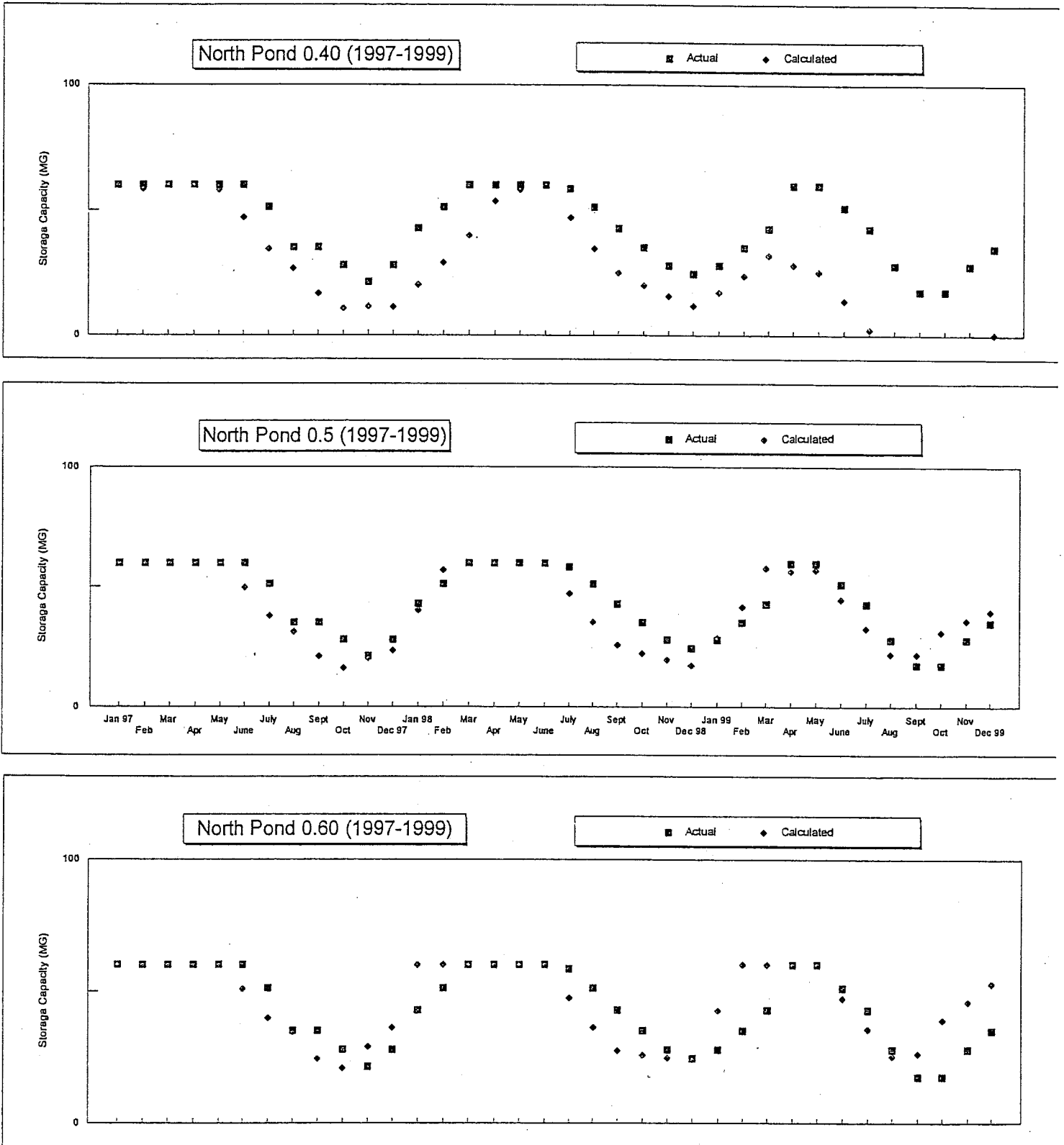

Figure 7 - North Pond Simulation (1997 - 1999)

Since historical reservoir elevations were not typically recorded for South Pond, the 0.45 average surface water inflow factor for North Pond was considered appropriate for South Pond. The watersheds are adjacent to each other and the characteristics are considered similar.

In 1995 actual runoff into South Pond was measured during four storm events as part of a University of Rhode Island (URI) study, *Assessment of Quantity and Quality of Runoff from the South Reservoir Drainage Area* by John Wingate. The same total rainfall that occurred in the four storm events was simulated in the computer model and the calculated runoff was compared to the measured runoff. To help verify whether the 0.45 average surface water inflow factor is appropriate for South Pond, four rainfall events were simulated in the computer model for South Pond to determine if the surface water inflow generated by the computer model from these four events matched the streamflow entering South Pond as measured in the 1995 URI study.

Comparisons between the actual runoff into South Pond and the calculated values are presented in Table 5. The results were within 1 to 7 percent other than the first storm event in November. This data represents a reasonable match and verified the 0.45 average surface water inflow factor for South Pond.

Table 5: Surface Water Inflow Factor Comparisons - South Pond

Rain Event	Month	Rain (in)	Runoff (MG)		Percentage of total Runoff	
			Actual	Calculated	Actual	Calculated
1	August	1.06	0.16	1.02	1.2	7.9
2	September	1.74	0.89	1.40	4.2	6.7
3	November	1.90	3.12	6.86	14	30
4	November	2.96	10.14	10.69	29	30

D. Safe Yield Evaluations

Utilizing the 0.45 average surface water inflow factor, the safe yield of North and South Pond was determined.

1. Yield Analysis Results/Individual Reservoirs

To estimate the safe yield of North and South Pond, precipitation data collected monthly from the Jamestown WTP from 1960 through 2000 was used. The water withdrawal was adjusted from each reservoir independently until all the useable storage capacity was utilized at least once during the period of simulation between 1960 and 2000. If the useable storage capacity was exceeded the safe yield was exceeded and the rate of withdrawal was reduced until the useable storage was not exceeded. The monthly water demand was based upon the mean monthly demand factors derived from 1999 and is presented in Table 6.

TABLE 6: Monthly Demand (MG)

Month	1999	Mean Monthly Demand Factor
January	6.09	0.93
February	5.18	0.79
March	5.85	0.89
April	6.23	0.95
May	7.28	1.11
June	7.57	1.15
July	8.51	1.30
August	8.10	1.24
September	6.81	1.04
October	5.92	0.90
November	5.49	0.84
December	5.63	0.86
Total	78.66	12

The safe yield of North and South Pond utilizing average surface water inflow (run-off) factors of 0.40, 0.45 and 0.50 are presented in Table 7.

Table 7: Safe Yield (gpd)

Average Surface Water Inflow Factor	North Pond	South Pond	Total
0.40	175,000	86,000	261,000
0.45	194,000	89,000	283,000
0.50	213,000	92,000	305,000

Table 7 shows that at an average surface water inflow factor of 0.45, there is adequate water supply to meet the projected 2020 water withdrawal requirement of about 285,000 gpd assuming that the Town continues to blend South Pond water in the raw water pipeline receiving water from North Pond. The average rate from South Pond would need to be about 60 gpm as compared to about 135 gpm from North Pond, a ratio of about 1:2.25. The continued use of the estimated 50,000 gpd well(s) may increase the total safe yield of the water supply system. The change in water level in North Pond and South Pond over the last 40 year period of record at an average surface water inflow factor of 0.45 and an average withdrawal rate of 283,000 gpd is presented in Figure 8.

Figure 8 - Safe Yield w/o Transfer

Jamestown Water Supply System

— South — North

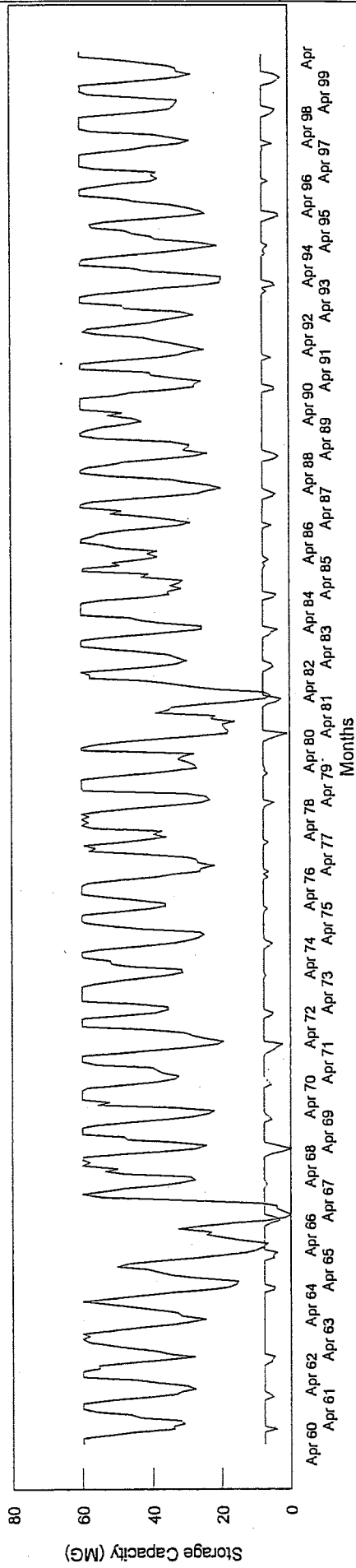

2. Yield Analysis Results with Reservoir Management

A second yield analysis was conducted considering the possible transfer of overflow from South Pond to North Pond in an effort to maximize the safe yield. Estimated overflow from both North and South Pond generated by the computer model for 1997 to 1999 is presented in Figure 7:

Figure 7 shows that a significant amount of water is lost from South Pond due to its small storage capacity in relation to its large drainage area. The installation of a raw water transfer pump station at South Pond and about 10,000 feet of pipeline from the transfer pump station to the north side of North Pond would provide the ultimate flexibility in terms of minimizing spillage and maximizing the safe yield. The safe yield of North Pond and South Pond utilizing average surface water inflow (run-off) factors of 0.40, 0.45 and 0.50 with transfer pumping are presented in Table 8.

Table 8: Safe Yield with Transfer Pumping (gpd)

Average Surface Water Inflow Factor	North Pond	South Pond	Total
0.40	304,000	80,000	384,000
0.45	321,000	83,000	404,000
0.50	333,000	88,000	421,000

Table 8 shows that at an average surface water inflow factor of 0.45, the safe yield with transfer pumping from South Pond to North Pond is increased from a total of 283,000 gpd to 404,000 gpd, an increase of 42%. A total transfer pump rate of about 180 gpm or two (2) 100 gpm pumps along with 10,000 feet of 6-inch pipe would be required.

If no water is withdrawn directly from South Pond for treatment at the WTP and all of the water is transferred to North Pond for treatment by natural processes around North Pond at the point of discharge and within North Pond then the total safe yield is estimated at about 403,000 gpd. A total transfer pump rate of about 190 gpm or two (2) 100 to 125 gpm pumps along with 10,000 feet of 6-inch pipe would be required. If the Town decides to transfer water up to North Pond, it should begin at a very low rate and water quality in North Pond should be monitored to determine if there is a degradation in water quality . A raw water quality monitoring program should be implemented regardless of the water supply management strategy.

Figure 9 - Average Overflow per Month

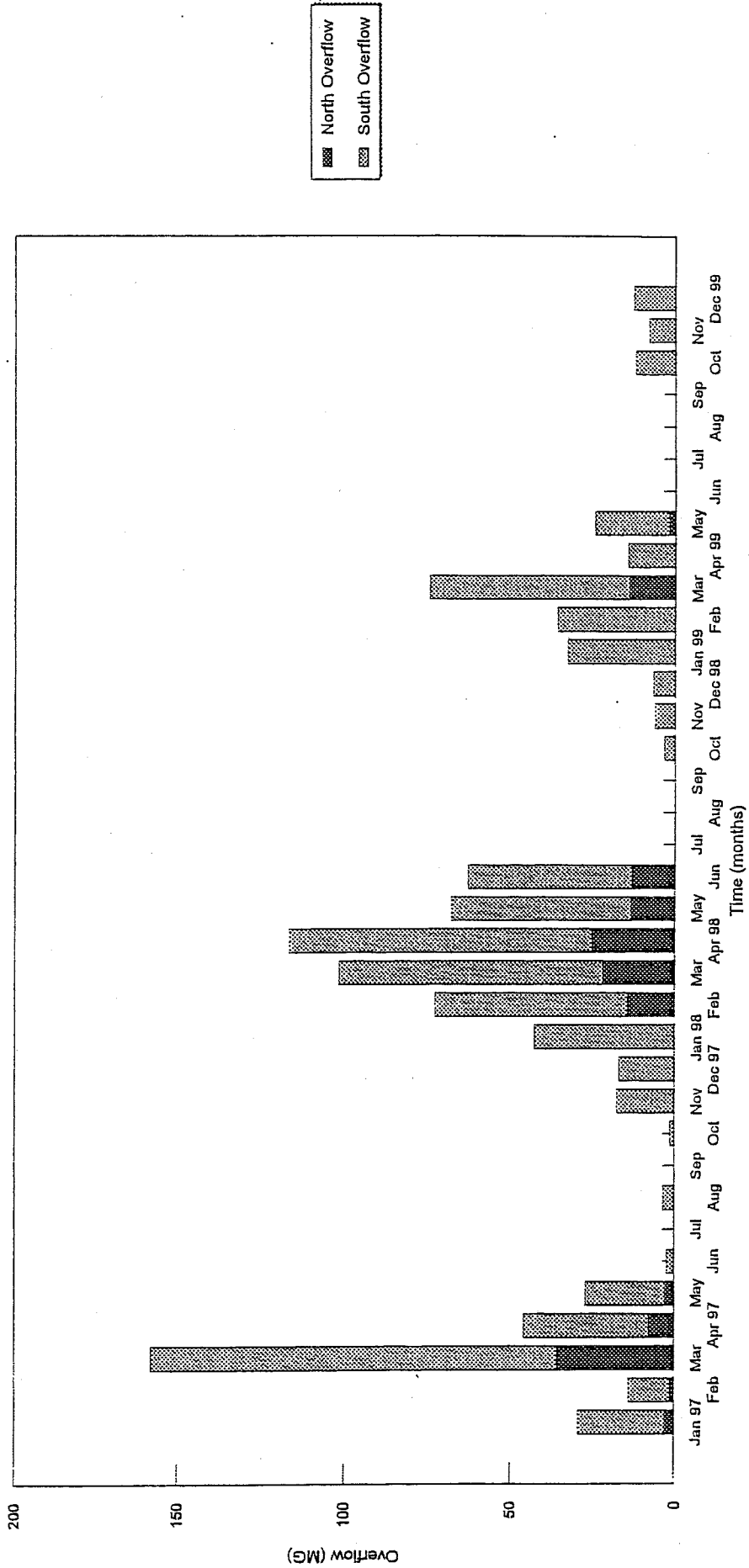

100

Storage Capacity (MG)

0

Figure 10 - Safe Yield w/ Transfer
Jamestown Water Supply System

— South — North

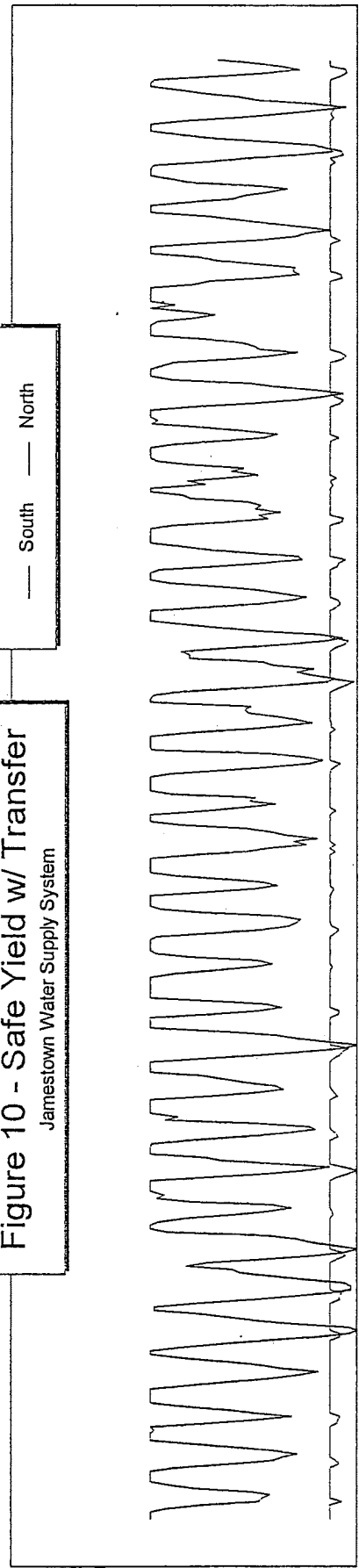

Apr 60 Apr 61 Apr 62 Apr 63 Apr 64 Apr 65 Apr 66 Apr 67 Apr 68 Apr 69 Apr 70 Apr 71 Apr 72 Apr 73 Apr 74 Apr 75 Apr 76 Apr 77 Apr 78 Apr 79 Apr 80 Apr 81 Apr 82 Apr 83 Apr 84 Apr 85 Apr 86 Apr 87 Apr 88 Apr 89 Apr 90 Apr 91 Apr 92 Apr 93 Apr 94 Apr 95

Months

Figure 11 - Safe Yield w/ Transfer (South storage and Overflow)

Jamestown Water Supply System

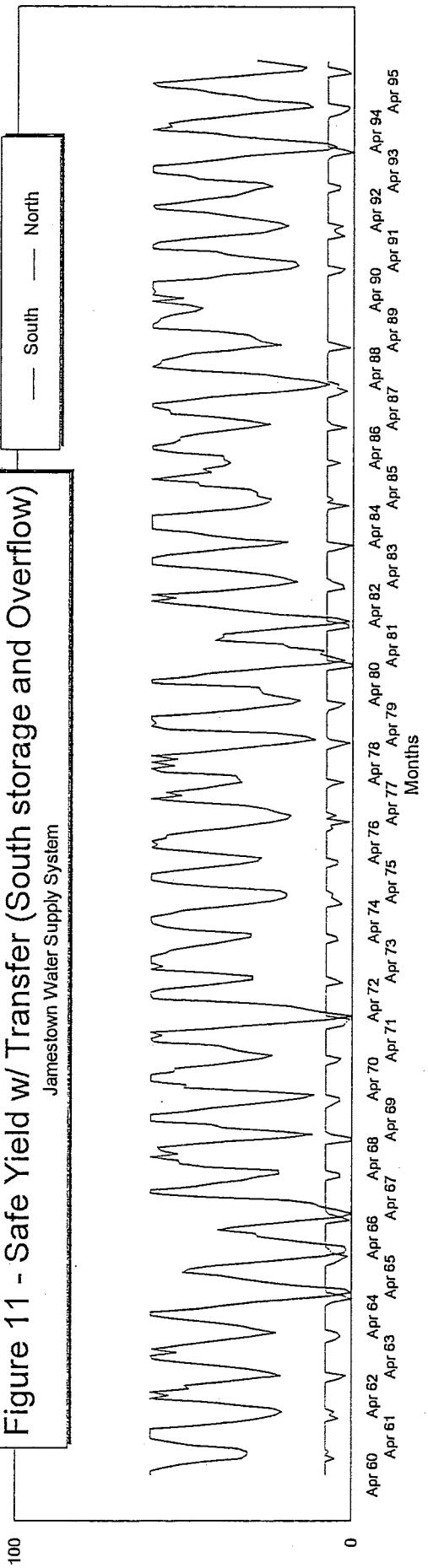

100

0

Storage Capacity (MG)

Months

APPENDIX E

Wellhead Protection Plan for the Community of Jamestown



Protecting Your Drinking Water

Wellhead Protection Plan For The Community of Jamestown

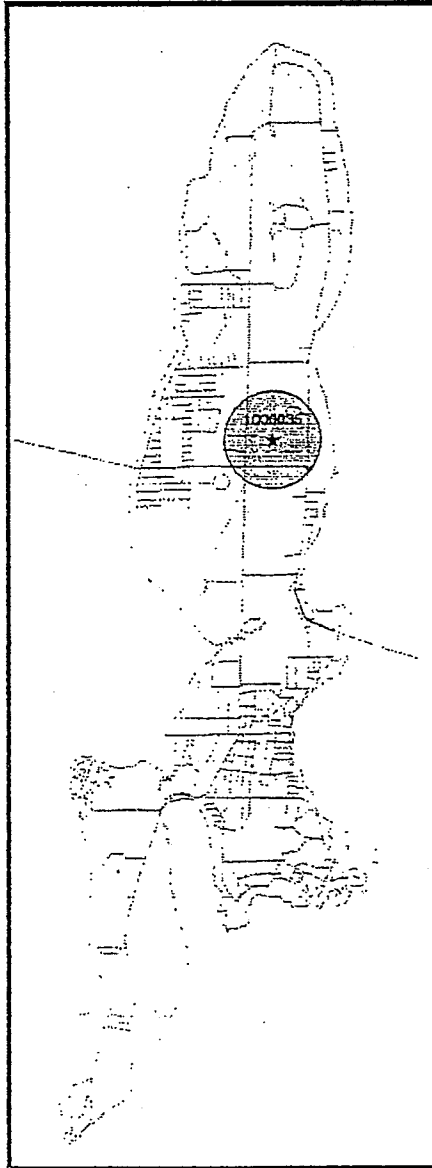

Developed by The Atlantic States Rural
Water Association
September 1997

Table of Contents

Section 1	Introduction	1.1
Section 2	Delineation Methodology	2.1
Section 3	Potential Contamination Source Inventory	3.1
Section 4	Inventory Results	4.1
	Ranking of Potential Contaminant Sources	4.2
Section 5	Management Plan	5.1
	Past Protection Strategies	5.1
	Land Ownership	5.1.1
	Facility Maintenance	5.1.2
	Proposed Management Strategies	5.2
	Land Acquisition	5.2.1
	Emergency Response Planning	5.2.2
	Road Signs	5.2.3
	Education	5.2.4
	Road Salting Controls	5.2.5
	Coordination of Effort With Local Community	5.2.6
	Implementation Schedule	5.3.1
Appendix	Labratory Analysis	

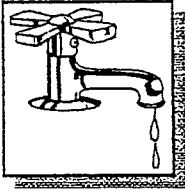

Section 1 Introduction

The Rules and Regulations for Groundwater Quality promulgated by the Rhode Island Department of Environmental Management, require that a Wellhead Protection plan (WHPP) be developed for each public groundwater supply well/wellfield in the State of Rhode Island. The WHPP is to be prepared in phases as follows:

- ◆ **Delineate Wellhead Protection Area** Delineation or identification of the farthest extent of contribution to a pumping well can be done using various methods ranging from using an arbitrarily fixed radii to using numerical modeling. The source water protection area for Jamestown was completed using a combination hydrologic mapping and the Theis equation..
- ◆ **Potential Contaminant Source Inventory** (PCSI) An inventory is required of each wellhead protection area for the purpose of identifying potential sources of groundwater pollution. As part of a RIDEM, RIDOH, (Wellhead Protection/ SDWA) project the inventory of potential contamination sources inside the wellhead protection area for the Jamestown community water system was completed.
- ◆ **Management Plan** Upon completion of the potential contaminant source inventory each water supplier is to develop a management plan that addresses sources of contamination identified during the inventory process.

This plan is to satisfy all requirements of the RIDEM "Rules and Regulations for Groundwater Quality." In addition this plan has been developed to meet the requirements of the Community of Jamestown.

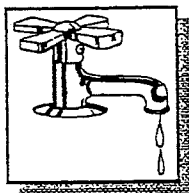

Section 2 Delineation Methodology

The Rhode Island Department of Environmental Management developed a wellhead protection area (WHPA) for the Jamestown Bedrock well using the Theis equation with a drainage basin or a portion of a drainage basin superimposed in the up-hill glacial drift. This method involves the use of analytical models to produce standardized wellhead protection, using the representative hydrological criteria, time of travel, and flow boundaries (locations of physical or hydrogeologic features controlling groundwater flow). See Figure 1.

As a result of this delineation process, approximately 280 acres of land was identified inside the (WHPA) for the Jamestown bedrock well.

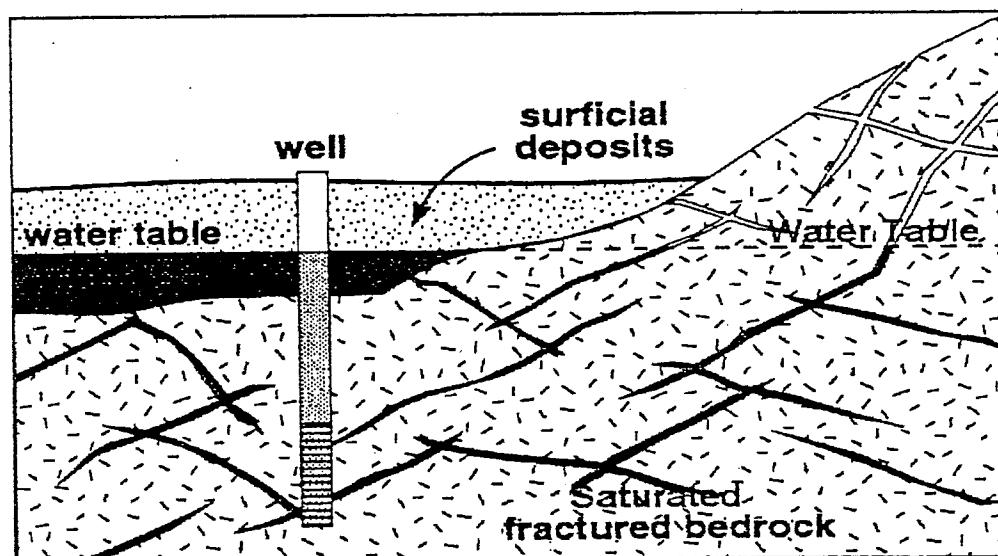

Figure 1.
Bedrock Well Cross Section

The Rhode Island Department of Environmental Management used the following criterion when developing the protection area for the Jamestown community well.

- (s) Drawdown = 1ft
- (Q) Pumping Rate= 50 gpm
- (T) Transmissivity = 50 ft. sq/day
- (t) Time of Travel = 200 days
- (S) Storage Coefficient =.01

As a result of this delineation process approximately 280 acres of land was identified as being located within the wellhead protection area for the Jamestown Community Well. (See Figure 2). This wellhead protection area is intended to be

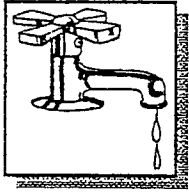
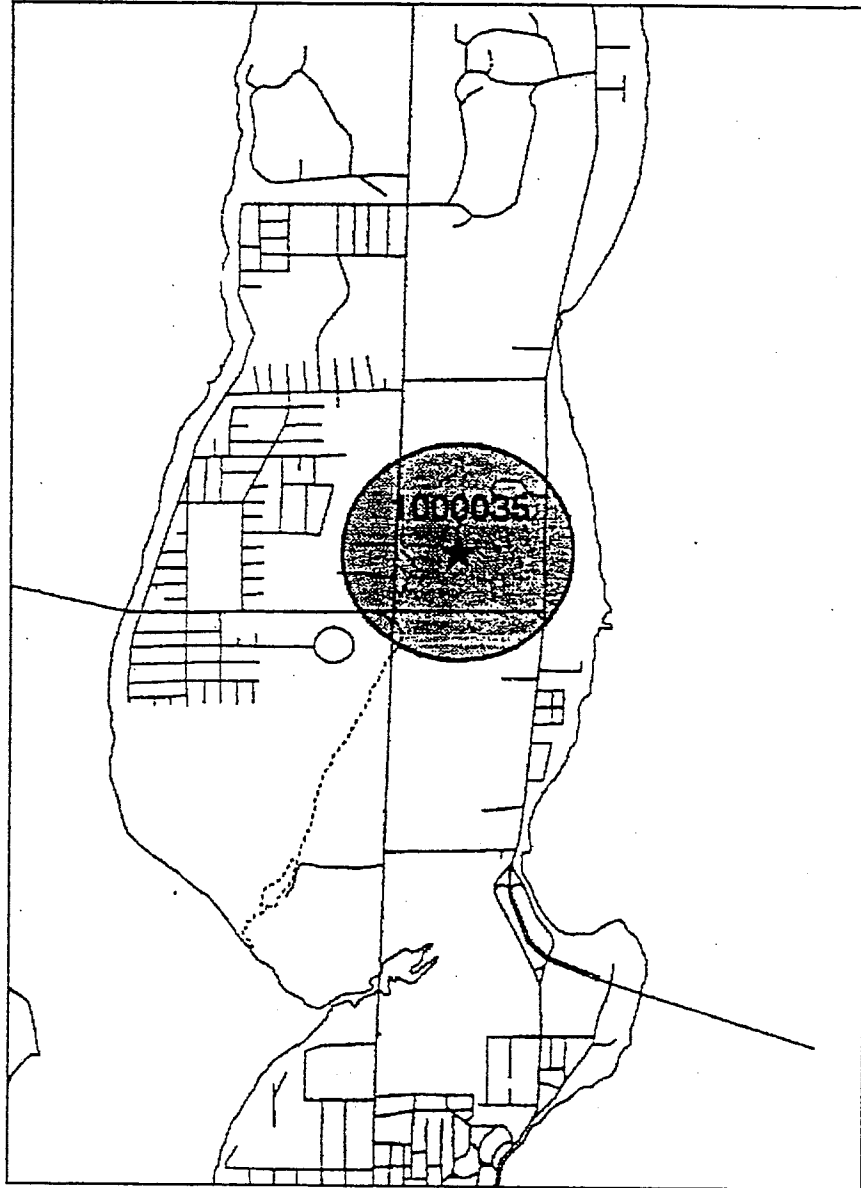
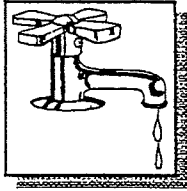

Figure 2
Jamestown Wellhead Protection Area
Jamestown, Rhode Island



Note: The Jamestown wellhead protection area is shaded Grey.
Map is not to scale.



Section 3 Potential Contamination Source Inventory

The Rhode Island Department of Environmental Management and the Atlantic States Rural Water and Waste Water Association conducted the inventory of the Jamestown Wellhead Protection Area in accordance with relevant Rhode Island regulations and guidelines including:

- ◆ Wellhead Protection A Guide For Small Communities, EPA Seminar Publication 1993
- ◆ Rhode Island Department of Environmental Management "Rhode Island Wellhead Protection Program" February 1990
- ◆ Inventory of Potential Sources of Groundwater Contamination In Wellhead Protection Areas- RIDEM Guidance Document, December 1992
- ◆ Rhode Island Department of Environmental Management "Preparing Water Supply Management Plans, A Guidance Document", October 1992

The identification of potential contamination sources within the Jamestown Wellhead Protection Area involved several steps. These five inventory steps are as follows:

- ◆ Purchase/ Review of Aerial Photographs
- ◆ Review of Town Records
- ◆ Potential Contamination Source Inventory
- ◆ Meeting with town Planners/ Facility operator
- ◆ Department of Environmental Management File Review

Purchase/ Review Aerial Photographs

Aerial photographs dated 1992 covering the delineated WHPA were purchased from the Rhode Island Department of Administration, Division of State Wide Planning. Boundaries of the delineated wellhead protection area were then transferred to the aerial photographs. This was done to assist in identifying parcels of land and roadways inside the wellhead protection area.

Review of Town Records

Town records were reviewed to identify past and present land uses considered a potential contamination source to the drinking water aquifer. Plat maps were obtained from the town to assist in identifying parcel numbers of potential contamination sources. Town officials were interviewed as to past and present land uses inside the wellhead protection area.

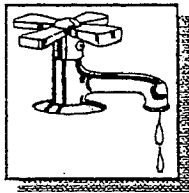

Potential Contamination Source Inventory

The potential contamination source inventory was conducted by the Rhode Island Department of Environmental Management as part of the 1994 Wellhead Protection/ Safe Drinking Water Act Integration Project. Aerial photographs were utilized to identify boundaries of the wellhead protection area. All roads inside the (WHPA) boundary were traveled and land uses / potential contamination sources were mapped on the aerial photographs. This information was then mapped on local tax maps.

Commercial and industrial activities, open space and agricultural land were all recorded onto aerial photographs during the wellhead inventory.

Meeting with Town Planners / Facility Owner

Meetings with the town planner and the facility owner were set up to discuss historical and present land uses, current zoning ordinances and potential development inside the wellhead protection area. The status of the town wellhead protection program was also discussed with respect to incorporating management strategies for wellhead protection.

Rhode Island Department of Environmental Management File Review

The following sources were reviewed at the Rhode Island Department of Environmental Management:

- ◆ **RCRA Generators** A listing of all registered hazardous waste generators. This list was used to identify land uses within the wellhead protection area.
- ◆ **Underground Storage Tank Master List** A listing of all registered underground storage tanks in the state of Rhode Island. This list was used to identify facilities located within the wellhead protection area with registered underground storage tanks.
- ◆ **CERCLIS Sites** A listing of all federal environmental remediation sites. This list was reviewed to identify any environmental remediation sites located within the wellhead protection area.
- ◆ **Underground Injection Control Master List** A listing of all underground injection control systems identified throughout the state of Rhode Island. Examples of UICs are floor drains and dry wells.
- ◆ **State Sites List** A listing of all state remediation sites. This list was reviewed to identify any environmental remediation sites located within the wellhead protection area.

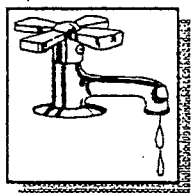

• **Leaking Underground Storage Tanks (LUST)** A Listing of all identified leaking underground storage tanks in the State of Rhode Island. This list was reviewed to identify any (LUSTs) located inside the wellhead protection area.

Information obtained from reviewing these files was then cross referenced with parcels of land and commercial facilities identified during the inventory process. As a result of this process a Wellhead Protection Area Inventory Table was developed. (See Table 1) This table identifies all potential contamination sources identified inside the wellhead protection area and any state information available for the site.

Table 1
 Jamestown Source Water Protection Area
 Potential Contaminant Source Inventory

ID No.	Map & Parcel No.	Facility Name/ Land Use	Location	(UST) File #	(ABT) File #	(UIC) File #	RCRA File #	CERCLIS	Relative Risk
J-1	5-449	Commercial Property	Severance Lane	NA	NA	NA	NA	NA	Medium
J-2	6-24	Newport Electric Generation Facility	Tashtassuck Road	NA	RI0023485	NA	NA	NA	High
J-3	4-59-81	Residential Properties Connected to Septic Systems	Reservoir Circle	NA	NA	NA	NA	NA	Low
J-4	4-86	Cleared Farmland	Route 138	NA	NA	NA	NA	NA	Low

NI= Non Identified

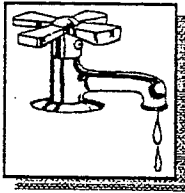

Section 4 Inventory Results

4.1 Jamestown Wellhead Protection Area

The Jamestown wellhead protection area is approximately 280 acres in size. Land uses inside the wellhead protection area consist primarily of residential and undeveloped land. State Highway 138 crosses the south central portion of the wellhead protection area. (WHPA)

A drinking water reservoir is located north central inside the wellhead protection area and approximately 200 feet northwest of the well. Undeveloped land was identified north of the reservoir and residential parcels were identified upon roadways running east, west and north of the well. Cleared undeveloped land is located along the west central portion of the wellhead protection area.

A commercial power generating station with 20,000 and 10,000 gallon above ground storage tanks was identified south central inside the WHPA and a commercial building with three 275 gallon above ground storage tanks was identified approximately 1400 feet west of the wellhead.

All residences and commercial facilities identified inside the wellhead protection area were identified as being connected to septic systems

The following sites warranted further discussion due to their location and proximity inside the wellhead protection area and information obtained during the RIDEM file review:

<u>ID No.</u>	<u>Site Description</u>
J-1	Commercial Property; This facility was identified as being utilized for commercial purposes. Three 275 gallon above ground storage tanks are located upon this property adjacent to a garage structure. This site was also identified as being connected to a septic system and as utilizing a well for drinking water purposes.
J-2	Newport Electric Co. ; This site is utilized as an electric power generating station. One 10,000 and a 20,000 gallon above ground tanks containing diesel fuel were identified on this site. Fiberglass secondary containment surrounds each tank.

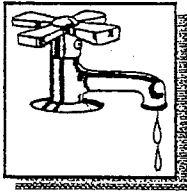
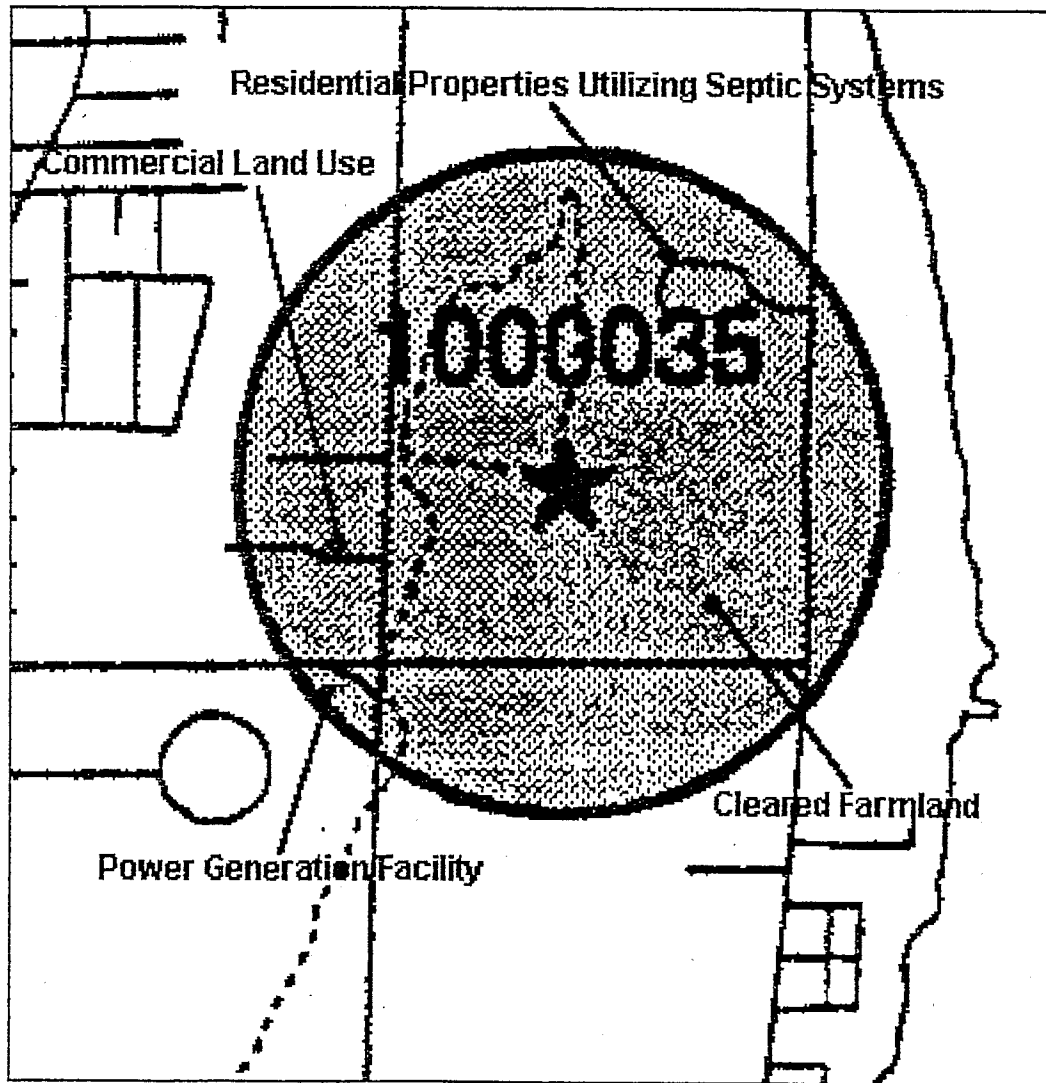
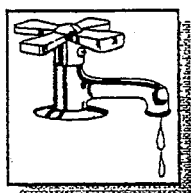

Figure 2
Potential Contamination Source Inventory Map
Jamestown Wellhead Protection Area



Note Map is not to scale



4.2 Ranking of Potential Contaminant Sources

The Rhode Island Department of Environmental Management Wellhead Protection Inventory Guidance Document (December 1992) identifies a ranking system for potential contaminant sources within each WHPA. The system is as follows:

Glacial deposit potential contaminant source is located in: Category Score

Stratified Drift		20
Till		2

Distance from the well (feet)

0-500		30
501-1,000		24
1,001-1,500		18
1,501-2,000		12
2,000+		6

Level of risk from type of land use:

High		50
Moderate		30
Low		10

The risk for each potential contaminant source can be determined by totaling the respective scores. This ranking system allows for the prioritization of potential contaminant sources by score totals. The following (Table 2) identifies all potential contaminant sources and their source rankings.

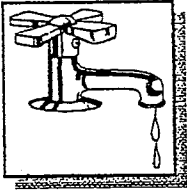

Table 2
Potential Contaminant Source Ranking

ID No.	Facility Name	Land Use Risk	Score	Glacial Deposit	Score	Distance	Score	Total Score
J-1	Commercial Property	Medium	30	Till	2	1400	18	50
J-2	Newport Electric	High	50	Till	2	2000	6	58
J-3	Residential Properties Utilizing Septic Systems	Low	10	Till	2	1300	18	30
J-4	Cleared Farmland	Low	10	Till	2	800	24	36

Notes: Land use categorized using a value of Low=10 Medium= 30 High = 50
 Stratified Drift Deposit= 20 Till Deposit = 2
 Distance From Wellhead Scoring 0-500 = 30. 501-1000=24. 1001-1500=18, 1501-2000=12. 2000+ = 6

Based upon the above ranking system the Newport Electric Power Generating Facility was identified as being the Highest threat to the well. A commercial property located 1400 feet from the well scored second highest. The residential properties utilizing septic systems and the Cleared farmland located approximately 800 and 1300 feet from the well were ranked as the lowest contaminate threats inside the wellhead protection area.

Protection efforts should be prioritized appropriately according to threat type and distance from the wellhead. Abandoned and existing un-identified underground storage tanks (USTs) should be located as part of a UST identification program to be conducted by the Community of Jamestown.

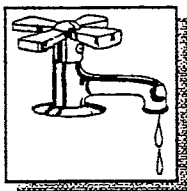

Section 5 Management Plan

This wellhead protection management plan has been developed in accordance with section 18.06c of the Rules and Regulations for groundwater quality. As required by these regulations the plan addresses past groundwater protection strategies, groundwater quality inside the wellhead protection area, identification of proposed management strategies and an implementation schedule.

5.1 Past Protection Strategies

There are several past and on going methods by which the Community of Jamestown has provided for groundwater protection. These methods include the following:

5.1.1 Land Ownership

The Rhode Island Department of Health (DOH) requires a 400 foot protective radius of ownership surrounding each public well. The community of Jamestown is in compliance with DOH regulations in that all land within the 400 foot radius is owned by the community. Land located south of the wellhead protection area is either owned by the community of Jamestown or is protected in conservation easements. Land north of the well is owned by the Community of Jamestown and is adjacent to a reservoir.

5.1.2 Zoning District (RR200)

This zoning district was developed to protect the town water supply reservoir while permitting residential dwellings at low density. Within the boundaries of this district land uses are strictly controlled by the community of Jamestown. Commercial non residential land uses are regulated by a special use permit. Residential developments are subject to a 200,000 square foot development area. (See Figure 3)

5.1.3 Underground Storage Tanks (USTs)

Underground storage tanks are not permitted in residential zoning districts on the island. Commercial properties are subject to a special use permit in the event of a proposed underground storage tank installation.

Zoning District (RR200) Jamestown, Rhode Island

Zoning District
(RR200) Rural Resi-
dential 200,000 square
feet is shaded Grey

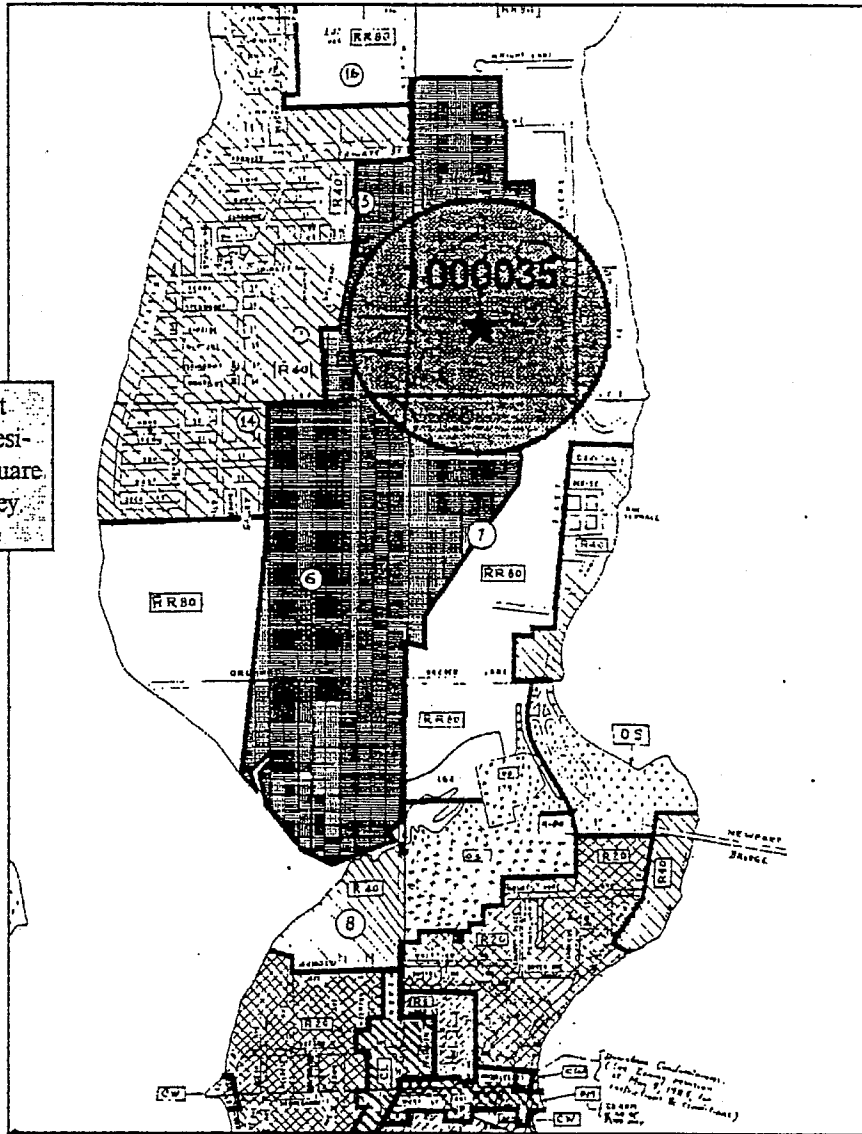

- (OS) = Open space
- (RR200) = Rural Residential 200,000 f²
- (RR80) = Rural Residential 80,000 f²
- (R40) = Residential 40,000 f²
- (R20) = Residential 20,000f²
- (R8) = Residential 8,000 f²
- (CL) = Commercial Limited
- (CD) = Commercial Downtown

- (CW) Commercial Water Front
- (DM) Downtown Mixed Use

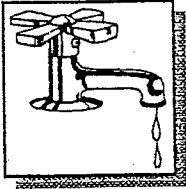

5.2 Groundwater Quality Within the WHPA

The community of Jamestown conducted analysis of the well water in JR-1 on 9/21/95. Well water testing results from the 1995 analysis are identified in the following tables. (See Appendix 1)

COMPOUNDS	RESULTS	DETECTION LIMIT
Pesticides/PCBIS (Method 508/608)		
Aldrin	ND	0.00005
Alpha-BHC	ND	0.00005
Beta-BHC	ND	0.00005
Delta-BHC	ND	0.00005
Gamma-BHC (Lindane)	ND	0.00005
Chlordane	ND	0.00025
4,4-DDD	ND	0.00005
4,41-DDE	ND	0.00005
4,4-DDT	ND	0.00005
Dieldrin	ND	0.00005
Endosulfan I	ND	0.00005
Endosulfan II	ND	0.00005
Endosulfan Sulfate	ND	0.00005
Endrin	ND	0.00005
Endrin Aldehyde	ND	0.00005
Heptachlor	ND	0.00005
Heptachlor Epoxide	ND	0.00005
Methoxychlor	ND	0.00025
Toxaphene	ND	0.0025
Aroclor-1016	ND	0.0005
Aroclor-1221	ND	0.0005
Aroclor-1232	ND	0.0005
Aroclor-1242	ND	0.0005
Aroclor-1248	ND	0.0005
Aroclor-1254	ND	0.0005
Aroclor-1260	ND	0.0005
Herbicides (method 515)		
2,4-D	ND	0.0010
2,4-DB	ND	0.0010
2,4,5-T	ND	0.00020
2,4,5-TP (Silvex)	ND	0.00010
Dalapon	ND	0.00010
Dicamba	ND	0.00010
Dinoseb	ND	0.00010
Dichloroprop	ND	0.00010
MCPA	ND	0.0010
MCPP	ND	0.0010
Pentachlorophenol	ND	0.00010
Picloram	ND	0.0010

ND = Not Detected

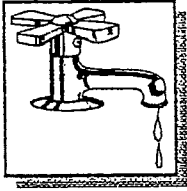

EPA METHOD 504

LIMIT

1,2 Dibromoethane (EDB)
1,2 Dibromo-3-Chloropropane (DBCP)

RESULTS	DETECTION
ND	0.00002
ND	0.00002

Results reported in mg/l
ND = None Detected

EPA METHOD 531.1

COMPOUND

Aldicarb
Aldicarb
Aldicarb
Baygon
Carbaryl
Carbofuran
3-Hydroxycarbofuran
Methiocarb
Methomyl
oxamyl

Sulfone
Sulfoxide

RESULTS	DETECTION LIMIT
ND	0.000354
ND	0.000163
ND	0.000380
ND	0.001000
ND	0.002000
ND	0.000160
ND	0.002000
ND	0.004000
ND	0.000500
ND	0.000196

Results reported in mg/l
ND = None Detected

EPA METHOD 548.1

COMPOUND

Endothall

RESULTS	DETECTION LIMIT
ND	0.00107

Results reported in mg/l
ND = None Detected

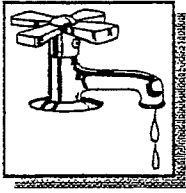

EPA METHOD 505

COMPOUND	RESULTS	DETECTION LIMIT
Aldrin	ND	0.000075
Alachlor	ND	0.000276
Atrazine	ND	
Alpha Chlordane	ND	0.000006
Gamma Chlordane	ND	0.000012
Chlordane (Technical)	ND	0.000183
Dieldrin	ND	0.000001
Endrin	ND	0.000001
Heptachlor	ND	0.000015
Heptachlor Epoxide	ND	0.000017
Hexachlorobenzene	ND	0.000017
Hexachlorocyclopentadiene	ND	0.000082
Lindane	ND	0.000001
Methoxychlor	ND	0.000003
Cis-Nonachlor	ND	0.000027
Trans-Nonachlor	ND	0.000011
Simazine	ND	0.002697
Toxaphene	ND	0.000400
Aroclor 1016	ND	0.000080
Aroclor 1221	ND	0.015000
Aroclor 1232	ND	0.000480
Aroclor 1242	ND	0.000310
Aroclor 1248	ND	0.000102
Aroclor 1254	ND	0.000102
Aroclor 1260	ND	0.000189
Butachlor	ND	0.000024
Propachlor	ND	0.000060
Metolachlor	ND	0.000067
Metribuzin	ND	0.000235

Results reported in mg/l

ND = None Detected

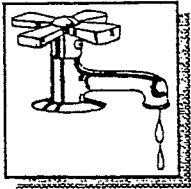

EPA METHOD 525.2

COMPOUND	RESULTS	DETECTION LIMIT
Alachlor	ND	0.00019
Atrazine	ND	0.00023
Benzo (A) Pyrene	ND	0.00015
Chlordane	ND	0.00031
Di (2-ethylhexyl) Adipate	0.0055	0.00015
Di (2-ethylhexyl) Phthalate	0.00061	0.00022
Endrin	ND	0.00019
Heptachlor	ND	0.00011
Heptachlor Epoxide	ND	0.00012
Hexachlorobenzene	ND	0.00023
Hexachlorocyclopentadiene	ND	0.00007
Lindane	ND	0.00026
Methoxychlor	ND	0.00010
PCB Screen	ND	0.00022
Simazine	ND	0.00011
Toxaphene	ND	0.00175
Aldrin	ND	0.00036
Butachlor	ND	0.00016
Dieldrin	ND	0.00017
Metolachlor	ND	0.00012
Metribuzin	ND	0.00019
Propachlor	ND	0.00014

Results reported in mg/l

ND = None Detected

The following compounds were also tested for during the 9/21/95 analysis of drinking water sampled from well JR-1:

COMPOUNDS	RESULTS	DETECTION LIMIT
Total Metals (mg/l)		
Iron	0.10	0.05
Sodium	11.4	3.0
Gross Alpha (pci/liter)	ND	2
Gross Beta (pci/liter)	5+/-1	3

SUMMARY OF ANALYSIS

No exceedences of maximum contaminate leves were identified during the analysis of JR-1 conducted in 9/21/95.

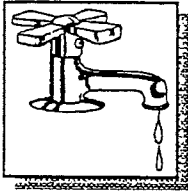

5.2 Proposed Management Strategies

As a municipality the community of Jamestown has the ability to regulate all land located within town boundaries. As such management strategies suggested inside this plan are tailored towards a community with the ability to control land uses within the wellhead protection area.

5.2.1 Land Acquisition

The Town of Jamestown should continue to peruse the purchase of all undeveloped land within the wellhead protection area. Land not currently developed should be left in a natural state providing a buffer from contaminants.

5.2.2 Emergency Response Planning

A formal emergency response plan should be developed to address specific hazardous situations such as a chemical spill or release. Coordination with the state is most important when developing this plan. Phone numbers such as DEM spill response and the local fire department should be included.

5.2.3 Road Signs

Road signs should be placed at the intersection of major highways and the boundaries of the wellhead protection area. These signs should have a phone number to call in the event of a spill and the sign should indicate that a vehicle is leaving or entering a public water supply.

5.2.4 Education

A major role in the development of this wellhead protection plan is the education of residents living within the wellhead protection area. Educational efforts should be conducted specifically in the following areas:

- ◆ **Septic Systems.** The lack of public sewers within the Jamestown WHPA results in all homes and businesses having their own septic systems or cesspools. Public education should be conducted to ensure that the owners of these homes and business are aware of the standard maintenance required for septic systems to ensure groundwater protection. In addition, home owners should be encouraged to remove cesspools and install septic systems which meet current codes and regulations.
- ◆ **Household Hazardous Waste.** The disposal of household hazardous waste (i.e.,

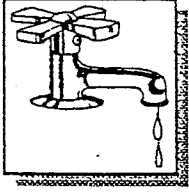

5.30 Implementation Schedule

An implementation schedule has been developed addressing goals and immediate corrective actions to properly implement the wellhead protection plan. A time frame and estimated cost for corrective actions are addressed in the following (table 3).

Table 3
Wellhead Protection Management Plan
Implementation Schedule And Costs

Management Action	Target Date	Estimated Cost
Road Salting Controls	Winter 1997	_____
Road Sign Installation Assumes six signs	Fall 1997	\$500
Emergency Response Planning	Winter 1997	_____
Public Education	Winter 1997	_____
Home Heating Oil Underground Storage Tank Study	Fall 1998	_____

NOTES:

Costs are estimates only

No costs are associated with education, planning and salting

APPENDIX F

2021 Consumer Confidence Report





RI Department of Health
Center for Drinking Water Quality

Consumer Confidence Report Certification Form

Submit this form by October 1 with documentation supporting evidence of direct delivery by July 1.

Water System Name: Jamestown Water Division

The system representative named below hereby certifies that the system's Consumer Confidence Report (CCR) was distributed directly on 6 / 30 / 22 to customers and appropriate notices of availability have been given. Further, the system representative certifies that the information contained in the report is correct and consistent with compliance monitoring data submitted to the Rhode Island Department of Health.

Name:	<u>Denise Jennings</u>			
Phone Number:	<u>401-423-9808</u>	Title:	<u>Water/Sewer clerk</u>	
Signature:	<u>Denise Jennings</u>		Date:	<u>8/5/22</u>

YOU MUST SUBMIT THE CCR TO EACH CONSUMER DIRECTLY AND BY USING AT LEAST ONE "GOOD FAITH" EFFORT METHOD. To summarize CCR delivery methods and good faith efforts taken, complete the checklist below by indicating each method used. Provide supporting documentation where applicable.

- Distributed CCR by mail or the following approved direct delivery method(s):
With customers 7/22 Water + Sewer Bill (attach supporting documentation)
- Notified customers of the following "one-click" URL web address that links directly to an electronic copy of the CCR: _____ (attach sample notification)
- Used "good faith" efforts to reach non-bill paying consumers, including (must use at least one):
 - Posted the CCR on the internet at Jamestownri.gov
 - Mailed the CCR to non-bill paying postal patrons within the service area (This option is for larger water systems that mail to every known address in a given zip code. Attach list of zip codes used.)
 - Advertised the availability of the CCR in news media (attach copy of press release)
 - Published the CCR in a local newspaper of general circulation (attach a copy of the published notice, including name of newspaper and date published)
 - Posted the CCR in public places (attach a list of locations)

- For large-volume, single-billed customers serving several persons, delivered instructions to disseminate the CCR, or the URL link to the CCR, to all non-bill paying consumers by public postings or direct delivery. (attach a list of delivery locations)
- Delivered to community organizations (attach a list of organizations)
- Other (attach a list and examples of other methods used if applicable)

For Systems with Special Considerations

- For systems serving at least 100,000 persons:* Posted the CCR on a publicly accessible internet site
- For Public Water Systems regulated by R.I. Public Utilities Commission (PUC):* Delivered the CCR to the PUC
- If using email to contact customers:* Regularly managed the email database(s) to ensure correct emails are being used for electronic delivery.
- For communities with large, non-English speaking populations:* Provided a CCR that contains information in the appropriate language(s). (attach examples)
- If applicable, included any outstanding Tier 3 Public Notices from previous year with a due date prior to July 1 of the current year in the CCR.

One recommendation is to attach the outstanding Tier 3 Public Notice to the end of your CCR. Be sure to send the Center for Drinking Water Quality the Public Notice Certification Form by the due date provided in the original Notice of Violation letter.

Submit this form and all supporting documentation to Rhode Island Department of Health, Center for Drinking Water Quality, 3 Capitol Hill, RM 209, Providence, RI 02908 or to DOH.RIDWQ@health.ri.gov

The Town of Jamestown 2021 Consumer Confidence Report was posted in the following public places and to single-billed addresses.

Lawn Avenue School-55 Lawn Avenue

Melrose Avenue School-76 Melrose Avenue

Jamestown Philomenian Library-26 North Road

Police Station-250 Conanicus Avenue

Recreation Building-41 Conanicus Avenue

Town Hall-93 Narragansett Avenue

Jamestown Housing Authority-45 Pemberton Avenue

Jamestown Senior Center-6 West Street

Sk Management Housing Complex-21 Pemberton Avenue

JAMESTOWN WATER DEPARTMENT

Consumer Confidence Report – 2022

Covering Calendar Year – 2021

RI1858419

This brochure is a snapshot of the quality of the water that we provided last year. Included are the details about where your water comes from, what it contains, and how it compares to Environmental Protection Agency (EPA) and state standards. We are committed to providing you with information because informed customers are our best allies. If you would like to learn more about our decision-making processes that affect drinking water quality, please call the Public Works Director at 401-423-7225.

Your water comes from:

Source Name	Source Water Type
NORTH (CARR) POND	Surface Water
WELL JR-1 (BR)	Ground Water
SOUTH (WATSON) POND	Surface Water

Buyer Name	Seller Name
There are no additional purchases to display.	

The two primary sources of water are North Pond and South Pond. One groundwater well, designated JR-1, is used as a supplemental water source during periods of the year when the water level in the reservoirs is lower. We disinfect our water and treat it for pH and corrosion control. Our treatment plant can produce 500,000 gallons of clean water a day.

The RI Department of Health, in cooperation with other state and federal agencies, has assessed the threats to Jamestown Water Department water supply sources. The assessment considered the intensity of development, the presence of businesses and facilities that use, store or generate potential contaminants, how easily contaminants may move through the soils in the Source Water Protection Area (SWPA), and the sampling history of the water.

Our monitoring program continues to assure that the water delivered to your home is safe to drink. However, the assessment found that the water source is at LOW RISK of contamination. This does NOT mean that the water cannot become contaminated. Protection efforts are necessary to assure continued water quality. The complete Source Water Assessment Report is available from Jamestown Water Department or the Department of Health at (401) 222-6867.

Some people may be more vulnerable to contaminants in drinking water than the general population. Immuno-compromised persons such as those with cancer undergoing chemotherapy, persons who have undergone organ transplants, people with HIV/AIDS or other immune system disorders, some elderly, and infants can be particularly at risk from infections. These people should seek advice about drinking water from their health care providers. EPA/CDC guidelines on appropriate means to lessen the risk of infection by *Cryptosporidium* and other microbial contaminants are available from the Safe Drinking Water Hotline (800-426-4791).

Drinking water, including bottled water, may reasonably be expected to contain at least small amounts of some contaminants. The presence of contaminants does not necessarily indicate that water poses a health risk. More information about contaminants and potential health effects can be obtained by calling the EPA's Safe Drinking Water Hotline (800-426-4791).

The sources of drinking water (both tap water and bottled water) included rivers, lakes, streams, ponds, reservoirs, springs, and wells. As water travels over the surface of the land or through the ground, it dissolves naturally occurring minerals and, in some cases, radioactive material, and can pick up substances resulting from the presence of animals or from human activity.

Contaminants that may be present in sources water before we treat it include:

Microbial contaminants, such as viruses and bacteria, which may come from sewage treatment plants, septic systems, livestock operations and wildlife.

Inorganic contaminants, such as salts and metals, which can be naturally-occurring or result from urban storm water runoff, industrial or domestic wastewater discharges, oil and gas production, mining or farming.

Pesticides and herbicides, which may come from a variety of sources such as storm water run-off, agriculture, and residential users.

Radioactive contaminants, which can be naturally occurring or the result of mining activity.

Organic contaminants, including synthetic and volatile organic chemicals, which are by-products of industrial processes and petroleum production, and also come from gas stations, urban storm water run-off, and septic systems.

In order to ensure that tap water is safe to drink, EPA prescribes regulation which limits the amount of certain contaminants in water provided by public water systems. Food and Drug Administration regulations establish limits for contaminants in bottled water, which must provide the same protection for public health.

Our water system is required to test a minimum of 3 samples per month in accordance with the Total Coliform Rule for microbiological contaminants. Coliform bacteria are usually harmless, but their presence in water can be an indication of disease-causing bacteria. When coliform bacteria are found, special follow-up tests are done to determine if harmful bacteria are present in the water supply. If this limit is exceeded, the water supplier must notify the public.

Water Quality Data

The following tables list all of the drinking water contaminants which were detected during the 2021 calendar year. The presence of these contaminants does not necessarily indicate the water poses a health risk. Unless noted, the data presented in this table is from the testing done January 1- December 31, 2021. The state requires us to monitor for certain contaminants less than once per year because the concentrations of these contaminants are not expected to vary significantly from year to year. Some of the data, though representative of the water quality, is more than one year old. **Our water system makes every effort to provide you with safe drinking water.**

Terms & Abbreviations

Maximum Contaminant Level Goal (MCLG): the "Goal" is the level of a contaminant in drinking water below which there is no known or expected risk to human health. MCLGs allow for a margin of safety.

Maximum Contaminant Level (MCL): the "Maximum Allowed" MCL is the highest level of a contaminant that is allowed in drinking water. MCLs are set as close to the MCLGs as feasible using the best available treatment technology.

Secondary Maximum Contaminant Level (SMCL): recommended level for a contaminant that is not regulated and has no MCL.

Action Level (AL): the concentration of a contaminant that, if exceeded, triggers treatment or other requirements.

Treatment Technique (TT): a required process intended to reduce levels of a contaminant in drinking water.

Maximum Residual Disinfectant Level (MRDL): the highest level of a disinfectant allowed in drinking water. There is convincing evidence that addition of a disinfectant is necessary for control of microbial contaminants.

Maximum Residual Disinfectant Level Goal (MRDLG): the level of a drinking water disinfectant below which there is no known or expected risk to health. MRDLGs do not reflect the benefits of the use of disinfectants to control microbial contaminants.

Non-Detects (ND): lab analysis indicates that the contaminant is not present.

Parts per Million (ppm) or milligrams per liter (mg/l)

Parts per Billion (ppb) or micrograms per liter (µg/l)

Picocuries per Liter (pCi/L): a measure of the radioactivity in water.

Millirems per Year (mrem/yr): measure of radiation absorbed by the body.

Monitoring Period Average (MPA): An average of sample results obtained during a defined time frame, common examples of monitoring periods are monthly, quarterly and yearly.

Nephelometric Turbidity Unit (NTU): a measure of the clarity of water. Turbidity

in excess of 5 NTU is just noticeable to the average person. Turbidity is not regulated for groundwater systems.

Running Annual Average (RAA): an average of sample results obtained over the most current 12 months and used to determine compliance with MCLs.

Locational Running Annual Average (LRAA): Average of sample analytical results for samples taken at a particular monitoring location during the previous four calendar quarters.

Testing Results for: JAMESTOWN WATER DEPARTMENT

Microbiological	Result	MCL	MCLG	Typical Source	Violation
COLIFORM (TCR)	In the month of August, 1 sample(s) returned as positive	Treatment Technique Trigger	0	Naturally present in the environment	No

Regulated Contaminants	Collection Date	Highest Value	Range (low/high)	Unit	MCL	MCLG	Typical Source	Violation
BARIUM	3/31/2021	0.01	0.007 - 0.01	ppm	2	2	Discharge of drilling wastes; Discharge from metal refineries; Erosion of natural deposits	No
Nitrate	3/31/2021	3/31/2021	0.06 - 0.16	ppm	10	10	Runoff from fertilizer use; Leaching from septic tanks, sewage; Erosion of natural deposits	No
Nitrate-Nitrite	4/30/2021	0.52	0.52	ppm	10	10	Runoff from fertilizer use; Leaching from septic tanks, sewage; Erosion of natural deposits	No

Disinfection Byproducts	Sample Point	Monitoring Period	Highest LRAA	Range (low/high)	Unit	MCL	MCLG	Typical Source	Violation
TOTAL HALOACETIC ACIDS (HAA5)	Distribution System	2021	25	10.6 - 28.4	ppb	60	0	Byproduct of drinking water disinfection	No
TTHM	Distribution System	2021	49	28.4 - 72.5	ppb	80	0	Byproduct of drinking water disinfection	No

Lead and Copper	Monitoring Period	90 th Percentile	Range (low/high)	Unit	AL	Sites Over AL	Typical Source
COPPER, FREE	2017 - 2019	0.12	0.02 - 0.338	ppm	1.3	0	Corrosion of household plumbing systems
LEAD	2017 - 2019	2	0 - 4	ppb	15	0	Corrosion of household plumbing systems

If present, elevated levels of lead can cause serious health problems, especially for pregnant women and young children. Lead in drinking water is primarily from materials and components associated with service lines and home plumbing. Your water system is responsible for providing high quality drinking water but cannot control the variety of materials used in plumbing components. When your water has been sitting for several hours, you can minimize the potential for lead exposure by flushing your tap for 30 seconds to 2 minutes before using water for drinking or cooking. If you are concerned about lead in your water, you may wish to have your water tested. Information on lead in drinking water, testing methods, and steps you can take to minimize exposure is available from the Safe Drinking Water Hotline or at <http://www.epa.gov/safewater/lead>.

Maximum Disinfection Level	MPA	MPA Units	RAA	RAA Units	Violation
2021 - 2021	0.1500	MG/L	0.1	MG/L	No

Total Organic Carbon	Number of Samples	RAA	Required Removal Ratio	Removal Ratio	Violation
5/1/2021 - 5/31/2021	12	1.46	1.0 RATIO	1.33	No

Analyte	Facility	Highest Value	Unit of Measure	Month Occurred	Violation
TURBIDITY	TREATMENT PLANT 1	0.09	NTU	June 2021	No

Radiological Contaminants	Collection Date	Highest Value	Range (low/high)	Unit	MCL	MCLG	Typical Source	Violation
No detected results were found in the past five years.								

During the 2021 calendar year, we had the below noted violation(s) of drinking water regulations.

Federal Compliance Period	Analyte	Comments
No Violations Occurred in the Calendar Year of 2021		

Additional Required Health Effects Language:

Coliforms are bacteria that are naturally present in the environment and are used as an indicator that other, potentially-harmful, bacteria may be present. Coliforms were found in more samples than allowed and this was a warning of potential problems.

There are no additional required health effects violation notices.

APPENDIX G

Hurricane Preparedness Plan



JAMESTOWN CIVIL DEFENSE PREPAREDNESS AGENCY

TOWN OFFICES

JAMESTOWN, RHODE ISLAND

EMERGENCY PREPAREDNESS PLAN FOR HURRICANE DEFENSE

FOR

TOWN OF JAMESTOWN, RHODE ISLAND

AUGUST 1980

ADOPTED 4/13/81

Amended 5/86

Amended 8/92

P R O C L A M A T I O N

ESTABLISHING THE JAMESTOWN CIVIL DEFENSE PREPAREDNESS AGENCY

WHEREAS; the Rhode Island Civil Defense Preparedness Act of 1973 provided for the clarification and strengthening of the roles of the governor, state agencies and local governments in the prevention of preparation for, and response to and recovery from disasters; and

WHEREAS; for the implementation of such purposes the said Act directs each city and town in the state to establish by proclamation an agency comparable and similar to the statewide disaster agency in the respective political subdivisions,

NOW THEREFORE; we, the members of the Town Council of Jamestown do hereby PROCLAIM the organization and establishment of the Jamestown Civil Defence Preparedness Agency headed by the Civil Defense Director. The Agency shall have such space, property and funds as are authorized by this council from time to time. The authority, powers and duties of the Agency shall be governed by the said Act and the Jamestown Civil Defense Preparedness Agency may act jointly, co-operate and assist other local agencies and the statewide agency.

IN WITNESS WHEREOF, we have hereunto set our hands and caused the seal of the Town of Jamestown to be affixed this 10th day of June in the year of our Lord nineteen hundred seventy-four, and of the Independence of the United States of America the one hundred ninety-eighth.

HURRICANE DEFENSE
JAMESTOWN, RHODE ISLAND

I. MISSION, AUTHORITY AND RESPONSIBILITY

A. Mission

To minimize the threat to life and property in the event of a hurricane, and to maintain and restore any and all facilities and services essential to this purpose.

B. Authority

The provisions of this Emergency Preparedness Plan for Hurricane Defense are promulgated under the authority of the "State of Rhode Island Civil Defense Preparedness Act of 1973".

C. Responsibilities

In the event of a Hurricane or during the threat of a Hurricane the Council of Defense of the Town of Jamestown, under the supervision and authority of the Town Council President, shall be the governing body of local civil authority whether a state of emergency by Federal, State or Town government has or has not been

declared. The coordinating agency for technical guidance, establishment and directives will be the Jamestown Civil Defense Preparedness Agency. The decisions and directives of the Council of Defense will be performed and enforced by the town organization under whose jurisdiction and capability such a decision or directive would prescribe. The Council of Defense shall be the five Council People and the Town Administrator.

1. Succession of Responsible Authority

In the event of the debilitation or demise of the entire Council of Defense and the Jamestown Civil Defense Director, the power and authority of local government will be delegated to a Council of Emergency for the Town of Jamestown. This power and authority as head of local government will be effective only for the duration of the Hurricane Emergency.

The Council of Emergency will be comprised of the following organizational officers.

- (a) Chief of Police - Council Chairman
- (b) Deputy Director of Civil Defense
- (c) Director of Public Works
- (d) Director of Recreation
- (e) Director of Water and Sewer
- (f) Town Engineer
- (g) Fire Chief
- (h) Commander of the Ambulance Association

The Council of Emergency will be assembled at the direction of the Chief of Police, in a place designated by the Chief of Police, and will be conducted by the Chief of Police. All council decisions will be by democratic vote and simple majority rule.

II. CONCEPT OF OPERATIONS

A. State of Emergency

In the event of an actual emergency brought about by an unusual incident or the imminence thereof which endangers the health, safety or resources of the people of the Town of Jamestown, the Town Council President may declare that a State of Emergency exists, and thereafter the Civil Defense Organization shall have and may exercise for such period as such State of Emergency exists or continues the

following additional powers:

1. To enforce all laws, rules and regulations relating to civil defense and to assume direct operational control of all civil defense forces and helpers in the Town.

B. Phases

Policies, procedures and directives prescribed in this Hurricane Plan provide guidance for appropriate actions to be taken during the following phases: Hurricane Watch, Hurricane Warning and Post Hurricane.

III. HURRICANE WATCH PROCEDURES

A. Initial Response

In all probability the Police Department will have the initial report of the implementation of a Hurricane Watch by the National Weather Service via the State Police teletype network or by Civil Defense STAR. Upon receiving such a report the on watch police officer should immediately notify the following town officials:

1. Chief of Police
2. Town Administrator
3. Director of Civil Defense
4. Director of Public Works
5. Director of Parks and Recreation
6. School Superintendent
7. Superintendent of Water and Sewer Division
8. Lighthouse Keeper
9. Harbor Master
10. Fire Chief
11. Newport Bridge

The National Weather Service normally issues a Hurricane Watch 24 to 36 hours before a Hurricane Warning would be expected to be issued.

B. Implementation of Hurricane Watch Procedures

Immediately upon received information that a Hurricane Watch has been established for the State of Rhode Island by the National Weather Service the following prescribed actions will be taken by the individual town organizations. These actions are essential and are to be construed as Council of Defense directives. Other actions and/or precautions deemed necessary and appropriate by the chief officer of the respective town organizations should be performed and/or implemented. A description of this action and the results thereof should be included in and forwarded with the Hurricane Watch Status Report.

C. Individual Organization Responses

1. Town Administrator

- a. Review the Hurricane Plan for the Town of Jamestown. Notify Town Council President of preparation activity.
- b. Park and collect keys to buses, mini-buses and all other vehicles normally stored at the Town Office. Verify that all vehicles are fully fueled and serviced.
- c. Contact all bus drivers and list those available and willing to support an island evacuation.
- d. Evaluate Hurricane Watch Status Reports from the various town organizations. If necessary delegate manpower requirements from one organization to another to accomplish Hurricane Watch preparations. Keep Town Council President and Civil Defense Director informed of status of preparations and possible problem areas.
- e. Complete Hurricane Watch Status Report.
- f. Contact Newport Electric to determine plans to locate utility trucks on Island.

2. Director of Civil Defense

- a. Commence official log of given situation. Log to contain at least: date, time, situation, state of emergency or not, and every volunteer in every organizations's name and if possible social security number.
- b. Commence tracking Hurricane.
- c. Alert key personnel and keep advised of situation.
- d. Alert Volunteer Civil Defense forces and volunteer organizations which support Civil Defense functions.
- e. Test all Civil Defense communications.
- f. Test all emergency power sources.
- g. Fuel all emergency power sources to 100%.
- h. Prepare E.O.C. for severe weather and Council of Defense occupancy.
- i. Establish liaison with local chapter of American Red Cross. Keep Red Cross advised of probability of evacuation and expected shelter occupancy.
- j. Contact public and private institutions known to have emergency power sources. Recommend testing and fueling at this time.
- k. Contact local radio and television stations and ask that Jamestown Civil Defense information be broadcast.

3. Chief of Police

- a. Cause to be delivered all hurricane advisories and bulletins to Town Administrator and Director of Civil Defense located at the Jamestown Fire Station.
- b. Alert all town police officers and place them

on 24 hour on-call duty.

- c. Check all emergency equipment including emergency generator.
- d. Test all police communications.
- e. Expedite required maintenance or repairs to all equipment and facilities.
- f. Prepare Police Station for sever weather including preparation of east sallyport for use as temporary morgue.
- g. At end of each working shift fuel ALL vehicles to 100%.
- h. Complete and have delivered Hurricane Watch Status report to the Town Administrator's Office.
- i. Determine number of Police Officers to be called for duty.
- j. Begin preparation of Manpower Allocation Report.

4. Director of Public Works

- a. Alert key personnel and place them on 24 hour on-call duty.
- b. Test All Public Works communications.
- c. Expedite maintenance and repairs to all equipment.
- d. Determine number of sand bags on hand and get more if necessary.
- e. Pick up real estate signs on right of ways and visually check all catch basins.
- f. Prepare all Public Works Garage and Town

Buildings for severe weather.

- g. Determine where specific vehicles will be located in the event of a Hurricane Warning and begin preparation of Manpower Allocation Report.
- h. Check operability of Emergency Generators. Fuel to 100%.
- i. Check level of available gasoline at Town Office pump.
- j. Review all Public Works projects to determine those that may suffer damage or cause extensive damage as the result of a hurricane. Upon completion of such review, keep the Town Administrator advised of the situation, discontinue work on projects considered to be endangered or dangerous in event of hurricane and make preliminary plans to move heavy equipment and materials to secure storage.
- k. Ascertain the need for and ready availability of materials for road blocks and traffic control as deemed necessary by the Chief of Police and Fire Chief, especially in East Ferry and Mackerel Cove areas.
- l. Complete and have delivered Hurricane Watch Status Report to the Town Administrator's Office.

5. Recreation Director

- a. Notify owners of unoccupied trailers that a Hurricane Watch is in effect and ask that they initiate plans to remove their trailer from Fort Getty.
- b. Have life guards secure the beach and shut off utility lines to the Beach House.
- c. Close Fort Getty to public recreation and

allow only those who need to evacuate personal property to enter.

- d. Co-ordinate with Jamestown Police Department for public address system equipped police cruiser to drive through Fort Getty and alert occupants of Hurricane Watch in effect. Also have announcements made as to time that water to the park will be secured.
- e. Secure all outdoor recreational and park equipment for severe weather. Move Fort Getty picnic tables to fort foundation and securely store and protect as possible.
- f. Remove tennis nets and properly store.
- g. Remove baseball field fence. Securely tie to Little League backstop to prevent possible projectile hazard.
- h. Fuel all vehicles to capacity at end of working day. Store vehicles at Town Offices and give the keys to the Town Administrator.
- i. Have grass mowed at and around helicopter landing sites.
- j. Complete and have delivered Hurricane Watch Status Report.
- k. Begin preparation of Manpower Allocation Report.

6. School Superintendent

- a. Alert key personnel and place on 24 hour on-call duty.
- b. Keep key personnel that are necessary to open the school and assist the Jamestown Chapter of the American Red Cross in shelter preparation informed of probability of shelter necessity.
- c. Contact and co-ordinate with the Jamestown Chapter of the American Red Cross the

preparation of the school as an emergency shelter.

- d. Complete and have delivered Hurricane Watch Status Report, also, make one copy for the Red cross Emergency Shelter Manager.
- e. Prepare school building and grounds for severe weather.
- f. Assignment of operating personnel to shelter.

7. Superintendent Water and Sewer Division

- a. Commence filling water tower to full capacity.
- b. Review and update information with all personnel within the Water Division who are required to be on duty during an emergency. Alert key personnel and place on 24 hour on-call duty.
- c. Check operability of all sources of emergency power and fuel to 100%.
- d. Prepare Water and Sewer buildings for severe weather.
- e. Fuel all vehicles to 100% at end of working day.
- f. Complete and have delivered Hurricane Watch Status Report to Town Administrator's Office.
- g. Begin preparation of Manpower Allocation Report.

8. Lighthouse Keeper

- a. Test all communications

- b. Make tour of Beavertail area and inform all occupants of Hurricane Watch in effect.
- c. Prepare Lighthouse and grounds for severe weather.
- d. Fuel all vehicles to 100% at end of working day.
- e. Inform Town Administrator of intent to stay or leave if Hurricane Watch is upgraded to Hurricane Warning.
- f. Complete and have delivered Hurricane Watch Status Report to Town Administrator's Office.

9. Harbor Master

- a. Liaise with national weather forecasters. Plot predicted time of arrival. Compute tidal influence and storm surge.
- b. Notify commercial and transient boaters of storm developments. Promulgate shelter information. Assist Civil Defense Director and other public safety (Police and Fire Departments) with public boating safety announcements.
- c. Check out all Harbor Master communications equipment.
- d. Complete and have delivered Hurricane Watch Status Report to Town Administrator's Office.

10. Fire Chief

- a. Alert all volunteer firemen and rescue units.
- b. Review and bring up to date all details and special assignments of volunteer firemen and rescue personnel.
- c. Test all communications.

- a. Review and update current information with all personnel on duty list.
- b. Test all communications.
- c. Fuel all vehicles to capacity.
- d. Load all ambulances to be stationed away from Ambulance Barn with extra disaster supplies.
- e. Secure Ambulance Barn for severe weather.
- f. Complete and have delivered Hurricane Watch Status Report to Town Administrator's Office.

IV. HURRICANE WARNING PROCEDURES

A. Initial Response

The Weather Bureau changes a Hurricane Watch to Hurricane Warning when there are indications that hurricane winds of 74 miles per hour or higher, or a combination of dangerously high water and very rough seas are expected in specified coastal areas. When a Hurricane Warning is announced, hurricane conditions are considered imminent and may begin immediately, although more likely within 24 hours. It is of utmost importance that precautionary actions be completed when a Hurricane Warning is announced.

B. Individual Organization Responses

1. Town Administrator

- a. Arrange for Council of Defense to meet at Emergency Operating Center (E.O.C.) to establish degree of readiness of municipality and to evaluate need and extent of evacuation.
- b. Meet with Police Chief, Fire Chief, Public Works Director to review all preparations.
- c. Bring all Hurricane Status Reports, personal notes on situation and Town vehicle keys to E.O.C.

- d. Begin preparation of Manpower Allocation Report.
- e. Check operability of all sources of emergency power and fuel to 100%.
- f. Dispatch Rescue Boat or co-ordinate with Harbor Master to verify that no campers or picnickers are on Dutch Island.
- g. Fuel all vehicles to 100%.
- h. Complete and have delivered Hurricane Watch Status Report.

11. Jamestown Chapter of the American Red Cross

- a. Alert key personnel and place them on 24 hour on-call duty.
- b. Commence emergency shelter preparation of Jamestown Elementary School.
- c. Contact shelter medical representative and verify availability for shelter assistance.
- d. Test all communications.
- e. Test all sources of emergency power and fuel to 100%.
- f. Maintain close liaison with Civil Defense and keep Civil Defense advised of any problem situations in emergency shelter preparation.
- g. Verify school building and grounds secured for severe weather.
- h. Complete and have delivered Hurricane Watch Status Report to Town Administrator's Office.

12. Jamestown Ambulance Association

2. Council of Defense

- a. Prepare to come and remain at E.O.C. during remainder of Hurricane Situation.
- b. Prepare and order final Evacuation Plan. Town Planner to report to E.O.C. and act as staff for E.O.C.

3. Director of Civil Defense

- a. Relocate C.D. Star from Police Station to E.O.C.
- b. Commence 24 hour E.O.C. watch.
- c. Establish communications with the State E.O.C.
- d. Establish meeting with Council of Defense to determine if evacuation is necessary.
- e. Review all Hurricane Status Reports with Town Administrator to assess degree of readiness and possible problem situations. Report conclusions to Council of Defense.
- f. Commence monitoring all island communications.
- g. Establish and co-ordinate coverage of Channel thirteen (13) on Citizens' Band Radio as the Jamestown emergency channel. Contact Jamestown Citizens' Band Radio Club and co-ordinate their assistance in adequate CB coverage of all channels.
- h. Establish Public Information Center at E.O.C., Civil Defense telephone number is 423-1381.
- i. Verify official log of given situation is correct and updated.
- j. Keep Jamestown Chapter of American Red Cross advised of evacuation intentions and need to

open shelter.

- k. If necessary, update radio and television broadcast information.

4. Chief of Police

- a. Maintain readiness to respond to evacuation procedures.
- b. Keep E.O.C. advised of traffic situation on island, particularly the bridge accesses.
- c. Notify E.O.C. of Manpower Allocation Plan.

5. Director of Public Works

- a. Relocate all public works equipment to higher ground.
- b. Pick up all loose equipment located throughout the Town.
- c. Locate one radio equipped public works truck at transfer station outfitted with emergency equipment. Verify that one chain saw with extra fuel is included among this emergency equipment.
- d. Locate heavy barrel barriers to East Ferry area and Mackerel Cove.
- e. Notify E.O.C. of Manpower Allocation Plan.

6. Recreation Director

- a. Evacuate all campers from Fort Getty.
- b. Secure electrical power at Fort Getty.
- c. Secure public restrooms at Fort Getty.
- d. Remove and store all trash cans from Fort Getty and other recreational areas. Have trash dumpster moved to old fort foundation,

securely store and protect as possible.

- e. Co-ordinate with Department of Public Works to insure Beach House has been disconnected from utilities.
- f. If town vehicles were used in Hurricane Warning preparations, refuel and store at Town Offices. Deliver vehicle keys to E.O.C. after preparations are complete.
- g. Advise campers of emergency shelter availability on Island.
- h. Notify E.O.C. of Manpower Allocation Plan.

7. School Superintendent

- a. Continue to co-ordinate with and assist the Red Cross in emergency shelter preparations.

8. Superintendent of Water and Sewer Division

- a. Keep Council of Defense at E.O.C. advised of status of filling water tower.
- b. Shut off non-essential water to all exposed, low-lying areas.
 - 1. East Ferry docks
 - 2. Shipyard on Raquet Road (Wharton's) Hydrant
 - 3. "Meredith & Clarke" block
- c. Notify E.O.C. of Manpower Allocation Report.

9. Lighthouse Keeper

- a. Make final tour of Beavertail area. Inform Council of Defense at E.O.C. of Beavertail situation.

10. Harbor Master

- a. Canvas transient boaters for shelter requirements. Relay to Civil Defense

personnel berthing and special medical and food requirements.

- b. Commence securing the waterfront.
 1. Facilitate commercial dock/wharf and float removal. Coordinate with Police and Fire Department officials for high ground storage and traffic control.
 2. Assist in traffic control at boat ramps.
 3. Have all commercial and pleasure craft moved from Town Docks.
 4. Direct movement of boats/floating equipment judged likely to break up or drag moorings.
 5. Clear East Side Beach of all small craft including: dinghies, catamarans and rubber boats.
 6. Patrol storm rigging efforts (installing pendants and chafing gear), notifying boat owners of problem areas via telephone or UHF frequencies.
- c. Conduct a final water patrol to ascertain that all boaters have taken shelter.
- d. Commence removal of town/harbor patrol craft.
- e. Secure office spaces. Remove records and electronic equipment to a safe place.
- f. Coordinate shelter requirements for transient boater personnel.
- g. Notify Castle Hill Coast Guard of individuals not heeding Harbor Master advise. Inform Coast Guard of storm preparations, locations of Harbor Master personnel and emergency communications frequencies in use.

- h. Ensure that electricity, fuel and water utilities have been secured at all waterfront facilities.
- i. Prepare a watch bill for the first 36 hours of the storm's aftermath: integrate additional manpower from Fire Department or Military Police personnel as provided.
- j. Review with assistants "Commissioner of Wreck" and wrecked goods requirements. Provide security arrangements for anticipated grounded vessels.

11. Fire Chief

- a. Disburse fire engine to north end of Island, to be located at Severence Lane.
- b. Notify E.O.C. of Manpower Allocation Report.

12. Jamestown Chapter of American Red Cross

- a. Open emergency shelter for Fort Getty campers if Council of Defense determines it is necessary.
- b. Open emergency shelter for Island residents if Council of Defense determines it is necessary.
- c. Maintain close liaison with Civil Defense of shelter preparation and influx of occupants.

13. Jamestown Ambulance Association

- a. Maintain close liaison with E.O.C. about traffic conditions, roadway availability and flooded areas.
- b. Co-ordinate with Civil Defense any information on availability of local hospital situations.
- c. Locate one ambulance at north end of island at Ambulance Association members home. Inform

Civil Defense of member's phone number and if radio equipped.

V. POST HURRICANE

Recovery from a Hurricane is not a task that can be immediately executed. The majority of work necessary to completely recover will take several months and involve numerous outside agencies. None the less, there are several actions that can and should be taken immediately to continue to insure the safety and welfare of Island residents.

A. Initial Response

1. Council of Defense

- a. Evaluate need to maintain emergency shelter.
- b. Evaluate need to maintain a "State of Emergency".
- c. Determine evacuated areas that may be re-entered by residents.
- d. Co-ordinate with Town Departments priorities and plans for restoration of island services and clean up.

2. Director of Civil Defense

- a. Maintain E.O.C. for public information and continue as coordinating agency in accomplishing restoration of Island services and clean up.
- b. Commence island damage assessment and co-ordinate Council of Defense and Federal and State agencies in disaster assistance.

3. Police Department

- a. Establish security patrols in evacuated areas. Co-ordinate security patrols with National

Guard.

- b. Establish check points leading into evacuated areas to control re-entry.
- c. Maintain close liaison with E.O.C. in order to be advised of what evacuated areas are eligible for re-entry and to co-ordinate assistance in crowd control, emergency rescue and clean up priority.

4. Town Engineer and Building Inspector

- a. Conduct inspection of evacuated areas to determine feasibility of re-entry and to locate homes and/or buildings which may have suffered structural damage and be unsafe to occupy.

5. Water and Sewer Department

- a. Conduct inspection of water and sewer mains for damage.
- b. Test reservoir and home wells for contamination as requested.

6. Director of Public Works

- a. Immediately commence clearing main roads of obstructions consistent with E.O.C. plan.

7. Lighthouse Keeper

- a. Conduct tour of Beavertail Area and advise Civil Defense at E.O.C. of situation and assistance needed.

8. Jamestown Chapter of the American Red Cross

- a. Maintain close liaison with Civil Defense about shelter situation.
- b. Advise Civil Defense of Red Cross damage assessment.

9. Harbor Master

- a. Assist with crowd control and waterfront safety.
- b. Continue vehicle patrols to Dumplings, Fort Wetherill, Fort Getty and Dutch Harbor to ascertain storm effects. Facilitate police/medical assistance as required.
- c. Maintain UHF watch as required with police, fire and USCG personnel.
- d. Maintain log of reported groundings and related incidents.

10. Fire Chief

- a. Maintain close liaison with E.O.C. to coordinate crowd control, emergency rescue and clean up.
- b. Assign volunteers to man emergency phone lines in Fire Station until such time as emergency operations are secured.

2. Sequence of Responsible Authority

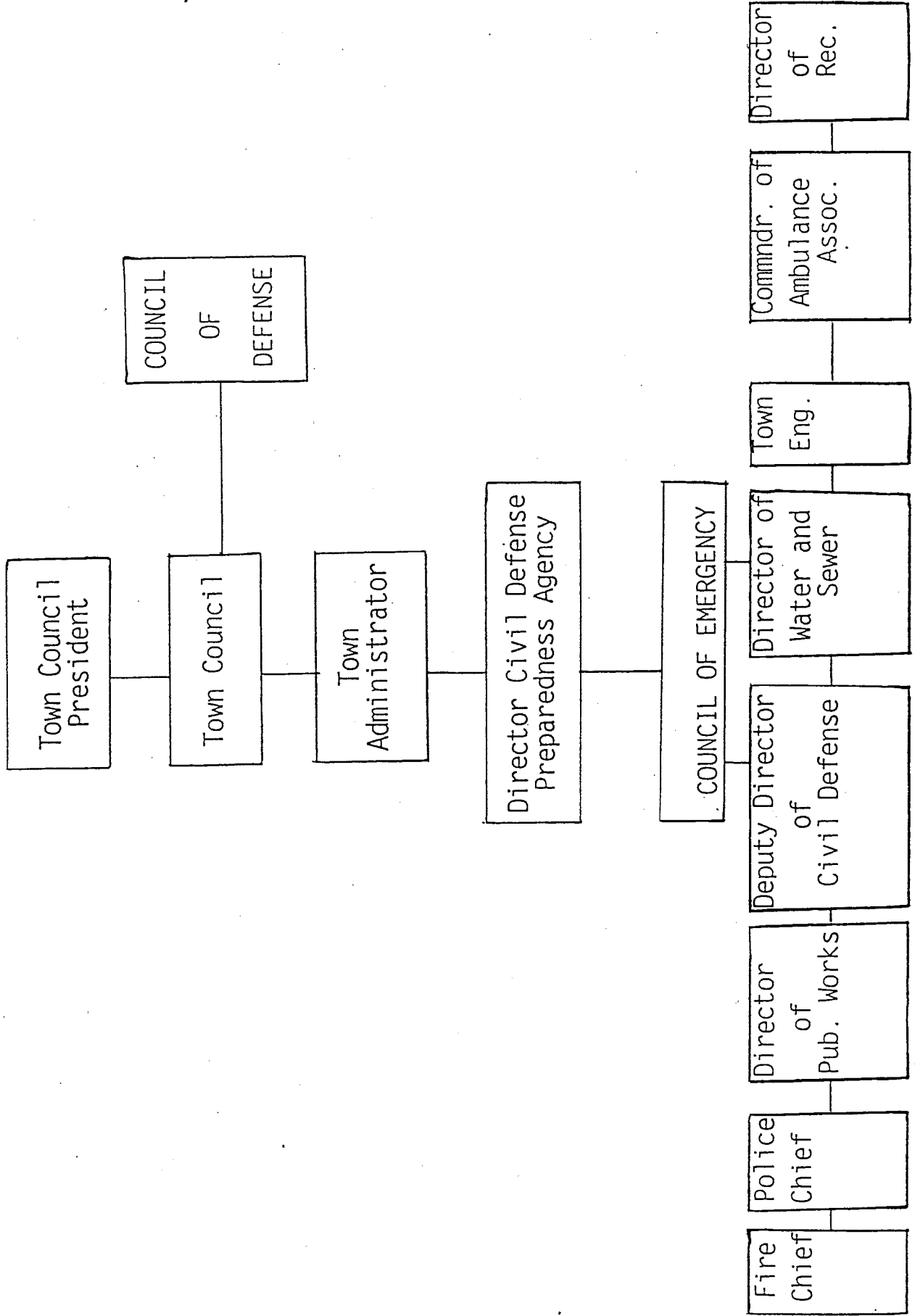

Hurricane Watch Status Report (con't)

POLICE / FIRE / PUBLIC WORKS / AMBULANCE

Please indicate where you intend to locate your vehicles during the actual Hurricane:

PUBLIC WORKS

Have all buildings and job sites been secure to the best of your ability?

Yes _____ No _____

List all buildings or Town owned sites where potential problems still exist:

Please indicate phone number of radio frequency where you can be contacted during:

Hurricane Preparation _____

Actual Hurricane _____

Post Hurricane _____

Signature

HURRICANE PREPARATION
Town of Jamestown

Hurricane Watch Status Report

Department: _____

Time: _____

Date: _____

Are all EMERGENCY VEHICLES available and fully operational?

Yes _____ No _____

If no, list vehicles not available:

Are all PUBLIC WORKS VEHICLES necessary for road clearing and road restoration available and fully operational?

Yes _____ No _____

If no, list vehicles not available:

Are all available MOBILE RADIO SYSTEMS operational?

Yes _____ No _____

List all vehicles with RADIO CAPABILITY:

HURRICANE PREPARATION
Town of Jamestown

Manpower Allocation Report

Department: _____

Time: _____

Date: _____

Hurricane Watch Notification: _____
Time Date

Hurricane Warning Notification: _____
Time Date

Number of personnel in your Dept: _____

Number of personnel not available (i.e. sick leave, vacation, away from Island): _____

Number of personnel available for immediate duty: _____

Please describe how you intend to schedule your personnel during the Hurricane Warning / Hurricane and Post Hurricane. Please be as precise as possible and include in this report where you intend to station your personnel during each stage.

HURRICANE WARNING:

Number on Duty: _____

Stationed At: _____

Notes: _____

HURRICANE:

Number on Duty: _____

Stationed At: _____

Notes: _____

POST HURRICANE:

Number on Duty: _____

Stationed At: _____

Notes: _____

Comments: _____

This completed report must be submitted to the E.O.C. within 2 hours of notification of Hurricane Warning.

Signed

APPENDIX H

Financial Statements



Budget vs Actual - Water
TOWN OF JAMESTOWN, RI
For 6/30/2021

Run: 2/02/2023 at 10:28 AM

	Annual Budget	P-T-D Actual	Y-T-D Actual	Remaining \$	% of Budget
2102 7000 70100 00 Salary- Public Works Director	26,103.00	1,719.53	26,153.37	(50.37)	100.19
2102 7000 70102 00 Salary- Accounting	43,162.00	4,344.55	46,672.73	(3,510.73)	108.13
2102 7000 70103 00 Salary - Treatment Plant Operator	78,537.00	2,750.20	76,057.56	2,479.44	96.84
2102 7000 70104 00 Ass't Plant Operator w/longevity	73,435.00	4,732.21	73,696.35	(261.35)	100.36
2102 7000 70105 00 Salary - Plant Operator	60,798.00	7,716.73	64,617.54	(3,819.54)	106.28
2102 7000 70511 00 Ass't Treatment Plant- OT	0.00	(798.64)	(798.64)	798.64	0.00
2102 7000 70513 00 Treatment Plant Operator - OT	13,000.00	2,690.40	17,087.40	(4,087.40)	131.44
2102 7000 70514 00 Ass't Treatment Plant Operator OT	11,000.00	1,491.45	15,014.95	(4,014.95)	136.50
2102 7000 70515 00 Plant Operator- OT	8,000.00	843.00	9,967.46	(1,967.46)	124.59
7000 Salaries	314,035.00	25,489.43	328,468.72	(14,433.72)	104.60
2102 7001 70900 00 SOCIAL SECURITY TAX	24,024.00	1,924.32	22,766.15	1,257.85	94.76
2102 7001 70901 00 Blue Cross/Delta Dental	41,239.00	7,314.61	47,150.32	(5,911.32)	114.33
2102 7001 70902 00 Worker's Compensation	30,000.00	0.00	20,000.00	10,000.00	66.67
2102 7001 70903 00 Retirement System	31,250.00	13,410.15	41,544.85	(10,294.85)	132.94
2102 7001 70906 00 Life Insurance	620.00	55.80	669.60	(49.60)	108.00
2102 7001 70910 00 Clothing	1,500.00	1,324.31	1,808.67	(308.67)	120.58
7001 Benefits	128,633.00	24,029.19	133,939.59	(5,306.59)	104.13
7000/7001 Salaries & Benefits	442,668.00	49,518.62	462,408.31	(19,740.31)	104.46
2102 7005 70601 00 Maintenance	6,000.00	400.00	3,753.79	2,246.21	62.56
2102 7005 70606 00 ALARM LINES	2,500.00	531.82	3,124.53	(624.53)	124.98
7005 Reservoirs/Rights of Way	8,500.00	931.82	6,878.32	1,621.68	80.92
2102 7006 70601 00 Maintenance	1,000.00	0.00	1,964.85	(964.85)	196.49
2102 7006 70636 00 Wells- Electricity	10,000.00	1,799.44	10,535.86	(535.86)	105.36
7006 Wells	11,000.00	1,799.44	12,500.71	(1,500.71)	113.64
2102 7010 70008 00 Lab Supplies - Water	10,000.00	3,440.57	15,583.18	(5,583.18)	155.83
2102 7010 70631 00 Chemicals	50,000.00	11,012.33	56,617.27	(6,617.27)	113.23
2102 7010 70632 00 Heat	13,500.00	0.00	9,014.95	4,485.05	66.78
2102 7010 70633 00 Equip. Maintenance	30,000.00	4,310.56	48,314.78	(18,314.78)	161.05
2102 7010 70634 00 Professional Services	5,000.00	376.00	626.00	4,374.00	12.52
2102 7010 70635 00 Telephone	3,500.00	616.49	3,113.74	386.26	88.96
2102 7010 70636 00 Pumpout- Electricity	40,000.00	7,277.99	41,204.30	(1,204.30)	103.01
2102 7010 70637 00 Bldg Maint	8,000.00	959.01	12,903.79	(4,903.79)	161.30
2102 7010 70638 00 State Testing	10,000.00	3,707.58	13,259.00	(3,259.00)	132.59
2102 7010 70639 00 License Fees	6,000.00	0.00	4,092.00	1,908.00	68.20
2102 7010 70643 00 PUMP OUT TREATMENT PLANT	3,200.00	0.00	3,839.02	(639.02)	119.97
2102 7010 70645 00 WATER SLUDGE DISPOSAL	16,000.00	4,607.00	13,789.06	2,210.94	86.18
7010 Pump Station & Treatment Plant	195,200.00	36,307.53	222,357.09	(27,157.09)	113.91
2102 7011 70636 00 South Pond- Electricity	2,000.00	214.75	1,353.40	646.60	67.67
2102 7011 70637 00 South Pond Transfer Pump	3,300.00	1,717.04	1,717.04	1,582.96	52.03
7011 South Pond Pre-Treatment Bldg	5,300.00	1,931.79	3,070.44	2,229.56	57.93
2102 7012 70636 00 Water Tower- Electricity	3,000.00	186.13	1,423.95	1,576.05	47.47
2102 7012 70643 00 Water Tower - Maintenance	500.00	0.00	0.00	500.00	0.00
7012 Water Tower	3,500.00	186.13	1,423.95	2,076.05	40.68
2102 7013 70644 00 Vehicles Gas & Oil	1,500.00	76.83	869.89	630.11	57.99
2102 7013 70645 00 Repair and Maintenance	4,000.00	436.60	633.19	3,366.81	15.83
7013 Vehicles	5,500.00	513.43	1,503.08	3,996.92	27.33
2102 7020 70651 00 Clamps	1,000.00	(386.85)	1,746.76	(746.76)	174.68
2102 7020 70652 00 Pipe	5,000.00	363.40	3,211.43	1,788.57	64.23
2102 7020 70653 00 Backfill & Excavation	2,000.00	0.00	0.00	2,000.00	0.00
7020 Maintenance & Laterials	8,000.00	(23.45)	4,958.19	3,041.81	61.98
2102 7030 70661 00 Service Repairs	10,000.00	(45.25)	12,268.78	(2,268.78)	122.69
2102 7030 70663 00 New Services	5,000.00	511.13	795.85	4,204.15	15.92
7030 Water Division Services	15,000.00	465.88	13,064.63	1,935.37	87.10
2102 7040 70672 00 Supplies/Expenses	14,000.00	2,512.66	12,727.50	1,272.50	90.91
7040 Meters	14,000.00	2,512.66	12,727.50	1,272.50	90.91
2102 7050 70681 00 Hydrants- Maintenance	7,500.00	1,894.12	2,053.10	5,446.90	27.37
7050 Hydrants	7,500.00	1,894.12	2,053.10	5,446.90	27.37
2102 7060 70923 00 Billing	6,500.00	1,916.21	5,433.50	1,066.50	83.59

Budget vs Actual - Water
TOWN OF JAMESTOWN, RI
For 6/30/2021

	Annual Budget	P-T-D Actual	Y-T-D Actual	Remaining \$	% of Budget
2102 7060 70924 00 Insurance	7,200.00	0.00	9,700.00	(2,500.00)	134.72
2102 7060 70925 00 Audit	4,000.00	0.00	0.00	4,000.00	0.00
2102 7060 70926 00 Supplies	6,000.00	284.38	6,224.01	(224.01)	103.73
7060 Administration	23,700.00	2,200.59	21,357.51	2,342.49	90.12
2102 7070 70300 00 Water Debt	434,011.00	0.00	0.00	434,011.00	0.00
2102 7070 70934 00 Depreciation Expense	0.00	191,171.21	191,171.21	(191,171.21)	0.00
2102 7070 70940 00 Interest	19,269.00	766.95	104,777.95	(85,508.95)	543.76
7070 Debt Service	453,280.00	191,938.16	295,949.16	157,330.84	65.29
2102 7080 70800 00 Water- Capital	100,000.00	0.00	0.00	100,000.00	0.00
7080 Capital	100,000.00	0.00	0.00	100,000.00	0.00
2102 7081 70602 00 PLC FOR FILTERS	0.00	3,325.92	4,655.92	(4,655.92)	0.00
2102 7081 70603 00 Control Panel SCADA	0.00	0.00	20,288.77	(20,288.77)	0.00
2102 7081 70604 00 Distribution	0.00	(22,211.56)	7,695.00	(7,695.00)	0.00
2102 7081 71303 00 WATER MANAGEMENT PLAN	0.00	(7,950.00)	0.00	0.00	0.00
Total Expenses	0.00	(26,835.64)	32,639.69	(32,639.69)	0.00
Total Expenses	1,293,148.00	263,341.08	1,092,891.68	200,256.32	84.51

Revenues - Budget Vs Actual
TOWN OF JAMESTOWN, RI
 For 6/30/2021

	Y-T-D Budget	Y-T-D Actual	\$ Variance	% Variance
Revenues				
2102 0000 40401 00 Metered Excess Water	365,381.00	408,970.26	(43,589.26)	111.93
2102 0000 40402 00 Minimum Charges	561,267.00	558,452.67	2,814.33	99.50
2102 0000 40403 00 Fire Protection Charges	170,000.00	170,000.00	0.00	100.00
2102 0000 40408 00 Income New Services	15,000.00	22,100.00	(7,100.00)	147.33
2102 0000 40409 00 Miscellaneous Income	17,000.00	7,602.62	9,397.38	44.72
2102 0000 40415 00 Interest Income	3,500.00	3,641.21	(141.21)	104.03
2102 0000 40420 00 Rental Water Tower	161,000.00	173,091.77	(12,091.77)	107.51
2102 7010 40001 00 Course Rent/Mistowski	0.00	0.00	0.00	0.00
2102 7010 40415 00 Interest Income	0.00	0.00	0.00	0.00
2102 7010 41100 00 Real Estate And Personal Prope	0.00	0.00	0.00	0.00
Total Revenues	<u>1,293,148.00</u>	<u>1,343,858.53</u>	<u>(50,710.53)</u>	<u>103.92</u>
Excess Revenue Over (Under) Expenditures	<u>1,293,148.00</u>	<u>1,343,858.53</u>	<u>(50,710.53)</u>	<u>103.92</u>

Budget vs Actual - Water TOWN OF JAMESTOWN, RI For 6/30/2020

	Annual Budget	P-T-D Actual	Y-T-D Actual	Remaining \$	% of Budget
2102 7000 70100 00 Salary- Public Works Director	24,845.00	2,194.08	25,805.11	(960.11)	103.86
2102 7000 70101 00 Salary - Ass't Treat Plant	0.00	(3,229.51)	(3,229.51)	3,229.51	0.00
2102 7000 70102 00 Salary- Accounting	40,571.00	2,225.84	43,029.26	(2,458.26)	106.06
2102 7000 70103 00 Salary - Treatment Plant Operator	69,548.00	9,553.14	78,403.01	(8,855.01)	112.73
2102 7000 70104 00 Ass't Plant Operator w/longevity	69,155.00	8,989.15	76,382.14	(7,227.14)	110.45
2102 7000 70105 00 Salary - Plant Operator	57,725.00	2,331.81	56,932.82	792.18	98.63
2102 7000 70339 00 License Yrly	0.00	1,800.00	1,800.00	(1,800.00)	0.00
2102 7000 70501 00 Water - Charge Backs	0.00	0.00	427.88	(427.88)	0.00
2102 7000 70511 00 Ass't Treatment Plant- OT	0.00	197.76	197.76	(197.76)	0.00
2102 7000 70513 00 Treatment Plant Operator - OT	13,000.00	144.92	13,735.53	(735.53)	105.66
2102 7000 70514 00 Ass't Treatment Plant Operator OT	11,000.00	1,265.94	12,340.23	(1,340.23)	112.18
2102 7000 70515 00 Plant Operator- OT	8,000.00	1,472.29	9,586.34	(1,586.34)	119.83
2102 7000 70910 00 Salary Adjustment	8,265.00	0.00	0.00	8,265.00	0.00
7000 Salaries	302,109.00	26,945.42	315,410.57	(13,301.57)	104.40
2102 7001 70900 00 SOCIAL SECURITY TAX	22,480.00	1,899.95	20,636.53	1,843.47	91.80
2102 7001 70901 00 Blue Cross/Delta Dental	37,379.00	13,613.37	42,266.09	(4,887.09)	113.07
2102 7001 70902 00 Worker's Compensation	32,000.00	0.00	30,000.00	2,000.00	93.75
2102 7001 70903 00 Retirement System	28,815.00	15,310.72	40,550.20	(11,735.20)	140.73
2102 7001 70906 00 Life Insurance	780.00	111.60	669.60	110.40	85.85
2102 7001 70910 00 Clothing	1,500.00	200.00	1,799.95	(299.95)	120.00
7001 Benefits	122,954.00	31,135.64	135,922.37	(12,968.37)	110.55
7000/7001 Salaries & Benefits	425,063.00	58,081.06	451,332.94	(26,269.94)	106.18
2102 7005 70601 00 Maintenance	6,000.00	4,193.00	8,690.08	(2,690.08)	144.83
2102 7005 70606 00 ALARM LINES	2,000.00	450.82	2,491.49	(491.49)	124.57
7005 Reservoirs/Rights of Way	8,000.00	4,643.82	11,181.57	(3,181.57)	139.77
2102 7006 70601 00 Maintenance	1,000.00	0.00	521.42	478.58	52.14
2102 7006 70636 00 Wells- Electricity	7,000.00	1,762.17	9,550.45	(2,550.45)	136.44
7006 Wells	8,000.00	1,762.17	10,071.87	(2,071.87)	125.90
2102 7010 70008 00 Lab Supplies - Water	10,000.00	2,283.67	10,429.13	(429.13)	104.29
2102 7010 70631 00 Chemicals	47,000.00	13,816.27	50,337.64	(3,337.64)	107.10
2102 7010 70632 00 Heat	13,500.00	0.00	10,195.67	3,304.33	75.52
2102 7010 70633 00 Equip. Maintenance	30,000.00	855.45	23,646.03	6,353.97	78.82
2102 7010 70634 00 Professional Services	5,000.00	0.00	745.00	4,255.00	14.90
2102 7010 70635 00 Telephone	2,500.00	845.58	3,502.63	(1,002.63)	140.11
2102 7010 70636 00 Pumpout- Electricity	38,000.00	7,243.82	38,317.43	(317.43)	100.84
2102 7010 70637 00 Bldg Maint	8,000.00	4,668.30	10,089.10	(2,089.10)	126.11
2102 7010 70638 00 State Testing	10,824.00	(342.00)	9,260.45	1,563.55	85.55
2102 7010 70639 00 License Fees	2,000.00	1,492.00	6,584.00	(4,584.00)	329.20
2102 7010 70643 00 PUMP OUT TREATMENT PLANT	2,000.00	0.00	3,120.00	(1,120.00)	156.00
2102 7010 70645 00 WATER SLUDGE DISPOSAL	16,000.00	4,558.00	15,810.33	189.67	98.81
7010 Pump Station & Treatment Plant	184,824.00	35,421.09	182,037.41	2,786.59	98.49
2102 7011 70636 00 South Pond- Electricity	1,650.00	159.73	1,965.06	(315.06)	119.09
2102 7011 70637 00 South Pond Transfer Pump	3,300.00	0.00	0.00	3,300.00	0.00
7011 South Pond Pre-Treatment Bldg	4,950.00	159.73	1,965.06	2,984.94	39.70
2102 7012 70636 00 Water Tower- Electricity	3,000.00	143.53	1,317.18	1,682.82	43.91
2102 7012 70643 00 Water Tower - Maintenance	500.00	0.00	0.00	500.00	0.00
7012 Water Tower	3,500.00	143.53	1,317.18	2,182.82	37.63
2102 7013 70644 00 Vehicles Gas & Oil	1,500.00	224.98	1,055.83	444.17	70.39
2102 7013 70645 00 Repair and Maintenance	4,000.00	0.00	3,768.09	231.91	94.20
7013 Vehicles	5,500.00	224.98	4,823.92	676.08	87.71
2102 7020 70651 00 Clamps	1,000.00	422.52	422.52	577.48	42.25
2102 7020 70652 00 Pipe	5,000.00	2,764.49	3,940.34	1,059.66	78.81
2102 7020 70653 00 Backfill & Excavation	2,000.00	3,238.21	3,238.21	(1,238.21)	161.91
7020 Maintenance & Laterials	8,000.00	6,425.22	7,601.07	398.93	95.01
2102 7030 70661 00 Service Repairs	8,000.00	3,533.41	11,456.54	(3,456.54)	143.21
2102 7030 70663 00 New Services	3,000.00	422.52	7,767.45	(4,767.45)	258.92
7030 Water Division Services	11,000.00	3,955.93	19,223.99	(8,223.99)	174.76
2102 7040 70672 00 Supplies/Expenses	14,000.00	2,471.24	13,366.85	633.15	95.48
7040 Meters	14,000.00	2,471.24	13,366.85	633.15	95.48

Budget vs Actual - Water
TOWN OF JAMESTOWN, RI
For 6/30/2020

	Annual Budget	P-T-D Actual	Y-T-D Actual	Remaining \$	% of Budget
2102 7050 70681 00 Hydrants- Maintenance	8,000.00	0.00	2,243.59	5,756.41	28.04
7050 Hydrants	8,000.00	0.00	2,243.59	5,756.41	28.04
2102 7060 70923 00 Billing	6,500.00	1,583.58	4,748.72	1,751.28	73.06
2102 7060 70924 00 Insurance	7,200.00	0.00	7,200.00	0.00	100.00
2102 7060 70925 00 Audit	4,000.00	4,000.00	4,000.00	0.00	100.00
2102 7060 70926 00 Supplies	6,000.00	(49.69)	5,769.11	230.89	96.15
7060 Administration	23,700.00	5,533.89	21,717.83	1,982.17	91.64
2102 7070 70300 00 Water Debt	434,677.00	0.00	0.00	434,677.00	0.00
2102 7070 70934 00 Depreciation Expense	0.00	194,268.76	194,268.76	(194,268.76)	0.00
2102 7070 70940 00 Interest	19,644.00	(3,817.37)	111,859.68	(92,215.68)	569.43
7070 Debt Service	454,321.00	190,451.39	306,128.44	148,192.56	67.38
2102 7080 70800 00 Water- Capital	100,000.00	0.00	0.00	100,000.00	0.00
7080 Capital	100,000.00	0.00	0.00	100,000.00	0.00
2102 7081 70005 00 North Reservoir	0.00	4,695.00	18,789.00	(18,789.00)	0.00
2102 7081 70602 00 PLC FOR FILTERS	0.00	0.00	2,480.00	(2,480.00)	0.00
2102 7081 70603 00 Control Panel SCADA	0.00	0.00	12,450.84	(12,450.84)	0.00
2102 7081 70604 00 Distribution	0.00	0.00	4,450.00	(4,450.00)	0.00
2102 7081 71303 00 WATER MANAGEMENT PLAN	0.00	8,500.00	9,075.00	(9,075.00)	0.00
Total Expenses	0.00	13,195.00	47,244.84	(47,244.84)	0.00
Total Expenses	1,258,858.00	322,469.05	1,080,256.56	178,601.44	85.81

Revenues - Budget Vs Actual
TOWN OF JAMESTOWN, RI
 For 6/30/2020

	Y-T-D Budget	Y-T-D Actual	\$ Variance	% Variance
Revenues				
2102 0000 40401 00 Metered Excess Water	362,250.00	323,768.77	38,481.23	89.38
2102 0000 40402 00 Minimum Charges	532,225.00	534,540.04	(2,315.04)	100.43
2102 0000 40403 00 Fire Protection Charges	170,000.00	170,000.00	0.00	100.00
2102 0000 40408 00 Income New Services	15,000.00	20,550.00	(5,550.00)	137.00
2102 0000 40409 00 Miscellaneous Income	17,000.00	9,871.92	7,128.08	58.07
2102 0000 40415 00 Interest Income	3,500.00	2,358.59	1,141.41	67.39
2102 0000 40420 00 Rental Water Tower	158,883.00	157,878.20	1,004.80	99.37
2102 7010 40001 00 Course Rent/Mistowski	0.00	0.00	0.00	0.00
2102 7010 40415 00 Interest Income	0.00	0.00	0.00	0.00
2102 7010 41100 00 Real Estate And Personal Prope	0.00	0.00	0.00	0.00
Total Revenues	<u>1,258,858.00</u>	<u>1,218,967.52</u>	<u>39,890.48</u>	<u>96.83</u>
Excess Revenue Over (Under) Expenditures	<u>1,258,858.00</u>	<u>1,218,967.52</u>	<u>39,890.48</u>	<u>96.83</u>

Revenues - Budget Vs Actual
TOWN OF JAMESTOWN, RI
 For 6/30/2022

	Y-T-D Budget	Y-T-D Actual	\$ Variance	% Variance
Revenues				
2102 0000 40401 00 Metered Excess Water	422,511.00	432,595.15	(10,084.15)	102.39
2102 0000 40402 00 Minimum Charges	587,169.00	590,188.73	(3,019.73)	100.51
2102 0000 40403 00 Fire Protection Charges	170,000.00	170,000.00	0.00	100.00
2102 0000 40408 00 Income New Services	15,000.00	18,240.72	(3,240.72)	121.60
2102 0000 40409 00 Miscellaneous Income	17,000.00	10,745.60	6,254.40	63.21
2102 0000 40415 00 Interest Income	3,500.00	3,849.16	(349.16)	109.98
2102 0000 40420 00 Rental Water Tower	161,836.00	170,695.11	(8,859.11)	105.47
2102 7010 40001 00 Course Rent/Mistowski	0.00	0.00	0.00	0.00
2102 7010 40415 00 Interest Income	0.00	0.00	0.00	0.00
2102 7010 41100 00 Real Estate And Personal Prope	0.00	0.00	0.00	0.00
Total Revenues	<u>1,377,016.00</u>	<u>1,396,314.47</u>	<u>(19,298.47)</u>	<u>101.40</u>
Excess Revenue Over (Under) Expenditures	<u>1,377,016.00</u>	<u>1,396,314.47</u>	<u>(19,298.47)</u>	<u>101.40</u>

Budget vs Actual - Water
TOWN OF JAMESTOWN, RI
For 6/30/2022

Run: 1/31/2023 at 2:55 PM

	Annual Budget	P-T-D Actual	Y-T-D Actual	Remaining \$	% of Budget
2102 7000 70100 00 Salary- Public Works Director	26,756.00	2,934.08	27,682.06	(926.06)	103.46
2102 7000 70102 00 Salary- Accounting	44,411.00	2,842.19	46,878.05	(2,467.05)	105.56
2102 7000 70103 00 Salary - Treatment Plant Operator	82,512.00	6,804.09	83,230.30	(718.30)	100.87
2102 7000 70104 00 Ass't Plant Operator w/longevity	75,636.00	5,758.48	76,641.17	(1,005.17)	101.33
2102 7000 70105 00 Salary - Plant Operator	62,608.00	5,963.90	63,665.44	(1,057.44)	101.69
2102 7000 70513 00 Treatment Plant Operator - OT	15,000.00	(1,093.02)	10,532.41	4,467.59	70.22
2102 7000 70514 00 Ass't Treatment Plant Operator OT	15,000.00	2,631.67	18,090.62	(3,090.62)	120.60
2102 7000 70515 00 Plant Operator- OT	10,000.00	1,214.09	11,750.33	(1,750.33)	117.50
7000 Salaries	331,923.00	27,055.48	338,470.38	(6,547.38)	101.97
2102 7001 70900 00 SOCIAL SECURITY TAX	25,392.00	(442.52)	24,900.95	491.05	98.07
2102 7001 70901 00 Blue Cross/Delta Dental	46,700.00	7,312.90	47,606.03	(906.03)	101.94
2102 7001 70902 00 Worker's Compensation	20,000.00	0.00	20,000.00	0.00	100.00
2102 7001 70903 00 Retirement System	36,750.00	2,553.30	30,363.30	6,386.70	82.62
2102 7001 70906 00 Life Insurance	670.00	58.05	685.35	(15.35)	102.29
2102 7001 70910 00 Clothing	1,500.00	1,500.50	1,780.47	(280.47)	118.70
7001 Benefits	131,012.00	10,982.23	125,336.10	5,675.90	95.67
7000/7001 Salaries & Benefits	462,935.00	38,037.71	463,806.48	(871.48)	100.19
2102 7005 70601 00 Maintenance	6,000.00	2,400.00	5,470.00	530.00	91.17
2102 7005 70606 00 ALARM LINES	2,500.00	734.33	3,899.73	(1,399.73)	155.99
7005 Reservoirs/Rights of Way	8,500.00	3,134.33	9,369.73	(869.73)	110.23
2102 7006 70601 00 Maintenance	1,000.00	0.00	250.10	749.90	25.01
2102 7006 70636 00 Wells- Electricity	10,000.00	1,725.55	9,898.02	101.98	98.98
7006 Wells	11,000.00	1,725.55	10,148.12	851.88	92.26
2102 7010 70008 00 Lab Supplies - Water	12,500.00	2,019.89	13,162.31	(662.31)	105.30
2102 7010 70631 00 Chemicals	55,000.00	16,757.08	50,570.80	4,429.20	91.95
2102 7010 70632 00 Heat	12,000.00	696.20	16,245.90	(4,245.90)	135.38
2102 7010 70633 00 Equip. Maintenance	40,000.00	4,766.37	21,656.10	18,343.90	54.14
2102 7010 70634 00 Professional Services	5,000.00	1,200.00	1,700.00	3,300.00	34.00
2102 7010 70635 00 Telephone	3,500.00	829.04	3,676.73	(176.73)	105.05
2102 7010 70636 00 Pumpout- Electricity	40,000.00	7,285.74	41,878.78	(1,878.78)	104.70
2102 7010 70637 00 Bldg Maint	8,000.00	1,337.87	7,065.67	934.33	88.32
2102 7010 70638 00 State Testing	11,000.00	2,993.00	14,199.95	(3,199.95)	129.09
2102 7010 70639 00 License Fees	6,000.00	2,317.50	4,117.50	1,882.50	68.63
2102 7010 70643 00 PUMP OUT TREATMENT PLANT	3,500.00	460.00	2,760.00	740.00	78.86
2102 7010 70645 00 WATER SLUDGE DISPOSAL	15,000.00	7,794.62	19,439.62	(4,439.62)	129.60
7010 Pump Station & Treatment Plant	211,500.00	48,457.31	196,473.36	15,026.64	92.90
2102 7011 70636 00 South Pond- Electricity	1,750.00	179.57	1,293.86	456.14	73.93
2102 7011 70637 00 South Pond Transfer Pump	3,000.00	0.00	0.00	3,000.00	0.00
7011 South Pond Pre-Treatment Bldg	4,750.00	179.57	1,293.86	3,456.14	27.24
2102 7012 70636 00 Water Tower- Electricity	2,000.00	134.30	1,483.93	516.07	74.20
2102 7012 70643 00 Water Tower - Maintenance	500.00	0.00	1,628.19	(1,128.19)	325.64
7012 Water Tower	2,500.00	134.30	3,112.12	(612.12)	124.48
2102 7013 70644 00 Vehicles Gas & Oil	1,500.00	199.00	1,574.00	(74.00)	104.93
2102 7013 70645 00 Repair and Maintenance	4,000.00	0.00	932.09	3,067.91	23.30
7013 Vehicles	5,500.00	199.00	2,506.09	2,993.91	45.57
2102 7020 70651 00 Clamps	1,000.00	2,540.45	8,146.72	(7,146.72)	814.67
2102 7020 70652 00 Pipe	5,000.00	2,540.45	4,208.73	791.27	84.17
2102 7020 70653 00 Backfill & Excavation	2,000.00	0.00	0.00	2,000.00	0.00
7020 Maintenance & Laterials	8,000.00	5,080.90	12,355.45	(4,355.45)	154.44
2102 7030 70661 00 Service Repairs	10,000.00	2,540.45	6,725.95	3,274.05	67.26
2102 7030 70663 00 New Services	5,000.00	2,540.45	5,074.18	(74.18)	101.48
7030 Water Division Services	15,000.00	5,080.90	11,800.13	3,199.87	78.67
2102 7040 70672 00 Supplies/Expenses	14,000.00	3,199.22	13,683.62	316.38	97.74
7040 Meters	14,000.00	3,199.22	13,683.62	316.38	97.74
2102 7050 70681 00 Hydrants- Maintenance	7,500.00	1,481.21	1,945.86	5,554.14	25.94
7050 Hydrants	7,500.00	1,481.21	1,945.86	5,554.14	25.94
2102 7060 70923 00 Billing	6,500.00	1,810.96	4,530.51	1,969.49	69.70
2102 7060 70924 00 Insurance	7,920.00	0.00	7,200.00	720.00	90.91

Budget vs Actual - Water
TOWN OF JAMESTOWN, RI
For 6/30/2022

	Annual Budget	P-T-D Actual	Y-T-D Actual	Remaining \$	%
					of Budget
2102 7060 70925 00 Audit	3,000.00	0.00	0.00	3,000.00	0.00
2102 7060 70926 00 Supplies	6,000.00	917.13	7,828.30	(1,828.30)	130.47
7060 Administration	23,420.00	2,728.09	19,558.81	3,861.19	83.51
2102 7070 70300 00 Water Debt	433,881.00	3,850.00	3,850.00	430,031.00	0.89
2102 7070 70934 00 Depreciation Expense	0.00	190,239.93	190,239.93	(190,239.93)	0.00
2102 7070 70940 00 Interest	68,530.00	(4,173.47)	91,417.33	(22,887.33)	133.40
7070 Debt Service	502,411.00	189,916.46	285,507.26	216,903.74	56.83
2102 7080 70800 00 Water- Capital	100,000.00	0.00	0.00	100,000.00	0.00
7080 Capital	100,000.00	0.00	0.00	100,000.00	0.00
2102 7081 70005 00 North Reservoir	0.00	1,511.70	3,611.70	(3,611.70)	0.00
2102 7081 70602 00 PLC FOR FILTERS	0.00	0.00	7,200.00	(7,200.00)	0.00
2102 7081 70603 00 Control Panel SCADA	0.00	(83,486.55)	44,121.57	(44,121.57)	0.00
2102 7081 70604 00 Distribution	0.00	0.00	14,843.43	(14,843.43)	0.00
2102 7081 71303 00 WATER MANAGEMENT PLAN	0.00	0.00	3,339.38	(3,339.38)	0.00
Total Expenses	0.00	(81,974.85)	73,116.08	(73,116.08)	0.00
Total Expenses	1,377,016.00	217,379.70	1,104,676.97	272,339.03	80.22

APPENDIX I

Jamestown Town Planner WSSMP Review Memorandum





TOWN OF JAMESTOWN
P.O. Box 377
93 Narragansett Ave.
JAMESTOWN, RHODE ISLAND 02835

Planning Office (401) 423-7210

April 2, 2024

Peter Georgetti, P.E. Managing Engineer
Pare Corporation
10 Lincoln Road, Suite 210
Foxboro, MA 02035

I have reviewed the 2024 Jamestown Water Supply System Management Plan (JWSSM) prepared by Pare Corporation. The JWSSMP is consistent with the 2015 Jamestown Comprehensive Community Plan (CCP) which is currently in the process of update. I have been integrally involved in the update of both documents and am confident the WSSM Plan will remain consistent with our updated CCP as the buildout information will be used for both documents.

Based on the results of the JWSSM, Jamestown is concerned and taking steps, through the update of the WSSMP and our Water and Sewer Regulations, to address reaching our water system capacity prior to buildout.

Thank you for your expert assistance in this process.

Sincerely,

Lisa W. Bryer, AICP
Town Planner

C: Michael Gray, P.E. Director of Public Works

APPENDIX J

2024 Water District Build-Out Analysis



**TOWN OF JAMESTOWN RHODE ISLAND
DEPARTMENT OF PUBLIC WORKS**

**WATER DISTRICT
BUILD-OUT ANALYSIS**

Prepared for:

Town of Jamestown
Department of Public Works
93 Narragansett Avenue
Jamestown, RI 02835

Prepared by:



Pare Corporation
8 Blackstone Valley Place
Lincoln, RI 02865

FINAL

APRIL 2024

FINAL

04/08/2024 7:51:50 AM



TABLE OF CONTENTS

<u>SECTION</u>	<u>PAGE NO.</u>
SECTION 1 – INTRODUCTION.....	3
1.1 Project Purpose and Scope.....	3
1.2 Assumptions and Considerations.....	3
Figure 1-1: Public Water and Sewer Service Area	4
1.3 Definitions.....	5
SECTION 2 – BUILD-OUT ANALYSIS.....	6
2.1 Residential.....	6
2.1.1 Vacant Property.....	6
2.1.2 Non-Vacant Property	7
2.1.3 Accessory Dwelling Units (ADUs).....	7
2.1.4 Summary of Residential Property Build-Out	8
2.2 Commercial.....	8
2.2.1 Vacant	8
2.2.2 Non-Vacant Property	9
2.2.3 Summary of Commercial Property Build-Out	9
SECTION 3 – WATER SYSTEM IMPACTS.....	10
3.1 Water Service Connections	10
3.2 Water Service Population.....	11
3.2.1 Residential Service Area Population.....	11
3.3 Current and Projected Water Demand.....	11
3.3.1 Residential Demand	11
3.3.2 Commercial Demand	12
3.3.3 Governmental Demand	12
3.4 Comparison of Capacity and Demand	13
3.5 Build-Out Over Time.....	14
3.6 Bedroom Count Analysis.....	15
SECTION 4 – CONCLUSIONS	16
APPENDICES	17
Appendix A – GIS Mapping and Data Tables	



Section 1 – Introduction

1.1 Project Purpose and Scope

This build-out analysis report has been prepared to reflect the most recent residential and commercial geographic information system (GIS) data that was used to determine the maximum potential future population growth over time under the current rules and regulations for the Town of Jamestown water district community.

The objective of this build-out analysis report is to get a sense of what the maximum potential future calculated population will be so that the Town of Jamestown can plan long-range goals for the water district community.

The last build-out analysis was conducted by the Town of Jamestown in the summer of 2010.

1.2 Assumptions and Considerations

The Town of Jamestown’s build-out analysis was conducted with the following assumptions and considerations:

1. The analysis is limited to the current limits of the water district, both the Rural District and the Urban District, where water mains currently exist. The analysis does not include any property north of the current Urban District. The limits of the Urban and Rural Districts are shown on Figure 1-1.
2. Existing dwellings in the Rural District that are connected to a private well will install a new well rather than tie into the water system, in the event that their current well becomes insufficient.
3. Current zoning regulations are intact.
4. The accessory dwelling units (ADUs) were determined based on any residential lot size in the water district greater than or equal to 20,000 square feet.
5. Average household size is 2.34 persons per household for 2017 through 2021 (based on 2022 U.S. Census Bureau Data - American Community Survey (ACS)).
6. An average of 15% of the land will be used for roads and infrastructure in subdivided residential area (this percentage was average for Jamestown subdivisions).
7. Wetland property protected under the Wetlands Protection Act, enforced by regulations administered by the Rhode Island Department of Environmental Management (RIDEM), and shown on the Rhode Island Geographic Information Systems (RIGIS), will not be built upon.
8. Extensions and connections into the Town of Jamestown’s water system are consistent with current regulations of the Board of Water and Sewer Commissioners.



Legend

-  Jamestown
-  Urban Water & Sewer District
-  Rural Water District

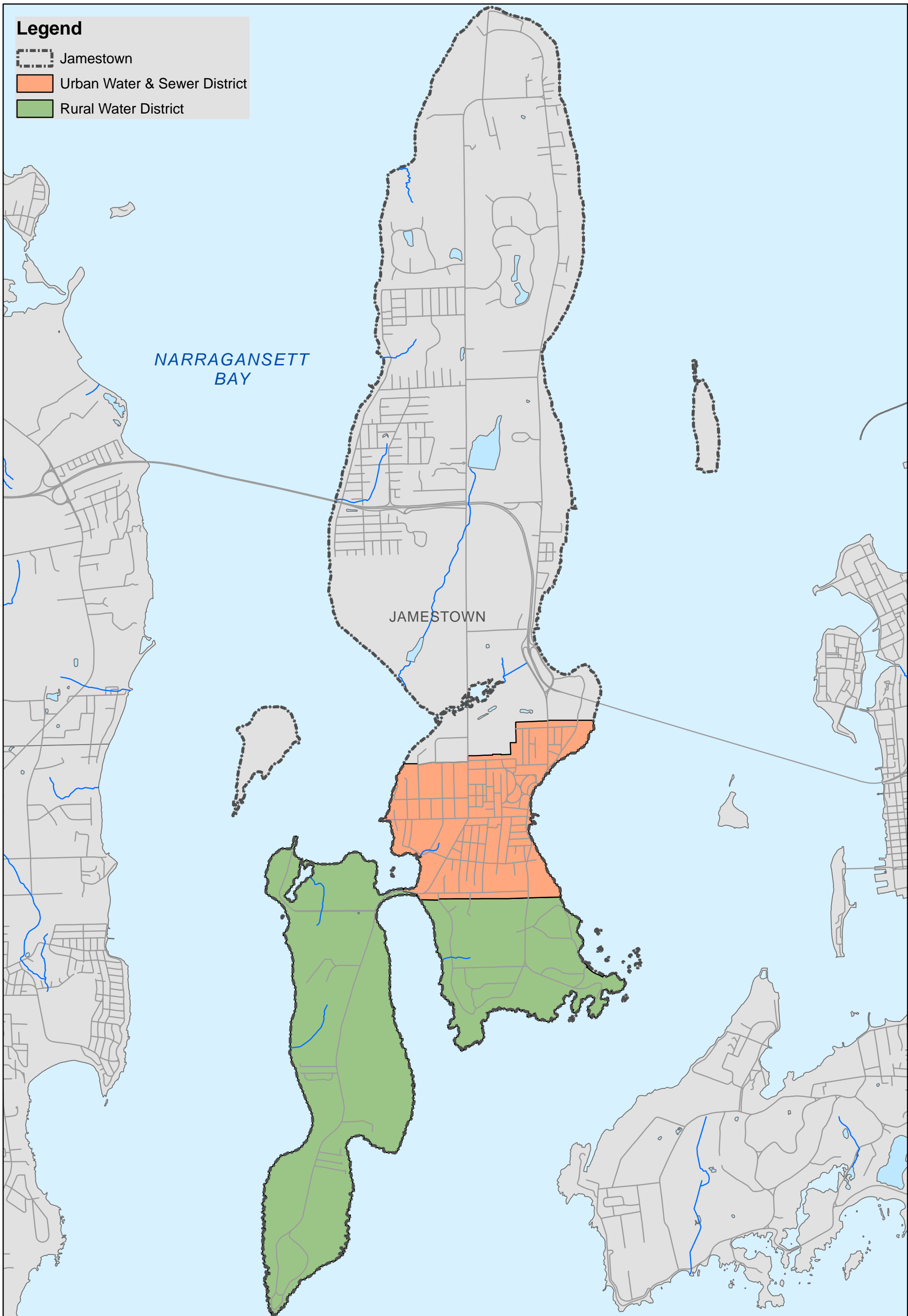

PARE CORPORATION
ENGINEERS - SCIENTISTS - PLANNERS
10 LINCOLN ROAD, SUITE 210
FOXBORO, MA 02035
508-543-1755

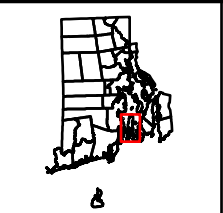
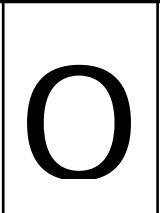

**JAMESTOWN PUBLIC WATER
AND SEWER SERVICE AREA
(EXISTING)**

1" = 3,000'

0" 1"

BAR IS ONE INCH ON ORIGINAL DRAWING

PROJECT NO.:	17103.02
DATE:	APRIL 2024
SCALE:	AS NOTED
DRAWN BY:	SJP
APPROVED BY:	JA

FIGURE 1-1

-
9. New residential development from urban and rural vacant lots were based on single family homes and ADUs throughout the entire water district. Developable sub-divided lots were calculated based on the minimum lot size for each vacant lot.
 10. All dwelling units are constructed to be occupied year-round.
 11. Governmental demand will remain unchanged through build-out.
 12. The assessors data used in this analysis is from October 2022.

1.3 Definitions

The following definitions may be useful in interpreting the build-out analysis:

Vacant - All land, urban or rural, that does not have any structures valued over \$10,000 and includes but is not limited to undeveloped residential and commercial lands, water bodies, agricultural land, recreation land, and open space lands.

Developable Land – All land that is currently not protected from development through deed restrictions, easements, or open space zoning and does not contain natural characteristics which would prohibit development (the presence of wetlands or constraints due to soil type).

Non-Vacant Developable Sub-Dividable Properties – Properties that have structures worth more than \$10,000 and have land in excess of two-times that required by zoning for the minimum lot size.

Accessory Dwelling Units – In January 2023, Rhode Island General Law 45-24, as amended and titled, “An Act Relating to Towns and Cities – Zoning Ordinances”, allows the owner to build an ADU on any lot with a total area of 20,000 square feet or more for which the primary use is residential and where the proposed ADU is located within the existing footprint of the primary structure or existing secondary attached or detached structure and does not expand the footprint of the structure.

Persons Per Household (PPH) – Equals the total 2022 population of Jamestown divided by the total occupied housing units (statistics from the 2022 U.S. Census Bureau-ACS).

Commercial – All commercial property and property which is partly commercial and partly residential. The commercial zones include commercial downtown (CD), commercial limited (CL), and commercial waterfront (CW). CD is Jamestown’s central business district. CL is the zone of Jamestown that transitions from strictly residential to commercial use areas. CW is the district that is intended to encourage water-dependent land uses.



Section 2 – Build-Out Analysis

The tables that follow show the results of residential and commercial build-out analysis, including projected future population growth within the service area, projected numbers of units, and total potential connections to the Town’s water service for water use projections. A build-out analysis reflects the greatest potential growth under the current regulatory framework (zoning and subdivision regulations). Other factors such as environmental and economic conditions influence land development and will ultimately influence the rate of population growth.

The build-out analysis is shown in detail on the spreadsheets and GIS figures provided in Appendix A. The tables presented below are a summary of the data and calculations provided in Appendix A.

2.1 Residential

The current minimum lot size for residential urban and rural single family property development are as follows:

Zone	Minimum Lot size (Square Feet)
R-8	8,000
R-20	20,000
R-40	40,000
RR-80	80,000

2.1.1 Vacant Property

The vacant developable properties were determined by creating a subset of the assessors’ data which met the following criteria:

1. Were within the Rural or Urban water districts; and
2. Were zoned residential; and
3. Were vacant and developable.

Existing conforming and non-conforming lots are included in the totals for “Developable Vacant Lots”.

New Lots that could be created from existing conforming vacant lots (i.e., lots that were at least 2 times the size of the minimum lot size allowed by zoning), are included under “Potential New Lots by Subdivision”.

Table 1 – Residential Vacant Developable Properties (Single Family Lot Sizes)

Property Type	Developable Vacant Lots	Potential New Lots by Subdivision	Total Vacant and New Lots
Rural Vacant Residential	36	36	72
Urban Vacant Residential	23	4	27
Totals	59	40	99



2.1.2 Non-Vacant Property

The non-vacant subdividable properties were determined by creating a subset of the assessors' data which met the following criteria:

1. Were within the Rural or Urban water districts; and
2. Were zoned residential; and
3. Had an existing structure; and
4. Were at least 2 times the size of the minimum lot size allowed by zoning.

The analysis also takes into consideration the estimated 15% of land required for each lot needed for roads and infrastructure.

Table 2 – Residential Non-Vacant Developable Properties (Single Family Lot Sizes)

Property Type	Potential New Lots by Subdivision
Rural Non-Vacant Residential	188
Urban Non-Vacant Residential	99
Totals	287

2.1.3 Accessory Dwelling Units (ADUs)

The number of possible existing accessory dwelling units (ADUs) were determined by creating a subset of the assessors' data which met the following criteria and are included under "ADUs from Existing Lots":

1. Were within the Rural or Urban water districts; and
2. Were zoned residential; and
3. Had a lot size greater than or equal to 20,000 square feet.

Vacant and Non-Vacant Lots that could be subdivided (as summarized above) and met the above criteria, are included below under "New ADUs from New Lots".

Table 3 – Existing and Potential ADUs

<u>Property Type</u>	<u>ADUs from Existing Lots</u>	<u>New ADUs from New Lots</u>	<u>Total ADUs</u>
Rural ADU Residential	275	224	499
Urban ADU Residential	283	40	323
Total ADUs	558	264	822

It should be noted that the total ADUs in this analysis includes the ADUs as a result of this build-out analysis, but also includes the ADUs that are possible from existing lots.



2.1.4 Summary of Residential Property Build-Out

The following table summarizes the total potential residential build-out in the rural and urban districts.

Table 4 – Residential Property Build-Out Summary

<u>Property Type</u>	<u>Lots</u>
Developable Vacant Lots	59
Potential New Lots by Subdivision - From Vacant Lots	40
Potential New Lots by Subdivision of Non-Vacant Lots	287
Potential New ADUs from New Lots	264
ADUs from Existing Lots	558
Total Vacant Lots, Potential New Lots + ADUs	1,208

2.2 Commercial

The current minimum lot size for commercial urban and rural single family property development are as follows:

Zone	Minimum Lot size (Square Feet)
CL	8,000
CD	5,000
CW	8,000*

* The CW zone lot size represents Multi-Family Use Minimum Lot Size.

2.2.1 Vacant

The vacant developable properties were determined by creating a subset of the assessors' data which met the following criteria:

1. Were within the Rural or Urban water districts; and
2. Were zoned commercial; and
3. Were vacant and developable.

Existing conforming and non-conforming lots are included in the totals for “Developable Vacant Lots”.

New Lots that could be created from existing conforming vacant lots (i.e., lots that were at least 2 times the size of the minimum lot size allowed by zoning), are included under “Potential New Lots by Subdivision”.

Vacant lots that could be subdivided (i.e., were at least 2 times the size of the minimum lot size allowed by zoning) are also included below.



Table 5 – Commercial Vacant Developable Properties

Property Type	Developable Vacant Lots	Potential New Lots by Subdivision	Total Vacant and New Lots
Urban Vacant Commercial	0	0	0
Totals	0	0	0

2.2.2 Non-Vacant Property

The non-vacant subdividable commercial properties were determined by creating a subset of the assessors' data which met the following criteria:

1. Were zoned commercial; and
2. Had an existing structure; and
3. Were at least 2 times the size of the minimum lot size allowed by zoning.

The analysis also takes into consideration the estimated 15% of land required for each lot needed for roads and infrastructure.

Table 6 – Commercial Non-Vacant Developable Properties

Property Type	Potential New Lots by Subdivision
Urban Non-Vacant Commercial	78
Totals	78

2.2.3 Summary of Commercial Property Build-Out

The following table summarizes the total potential commercial build-out in the rural and urban districts.

Table 7 – Commercial Property Build-Out Summary

<u>Property Type</u>	<u>Lots</u>
Developable Vacant Lots	0
Potential New Lots by Subdivision	78
Total Vacant Lots, Potential New Lots + ADUs	78



Section 3 – Water System Impacts

3.1 Water Service Connections

Based on the analysis in Section 2, below is a summary of the potential number of new units at full build-out. For this analysis, it is assumed that each new lot or ADU will result in 1 new water service connection.

Table 8 – Residential and Commercial Property Build-Out Summary

<u>Property Type</u>	<u>Lots</u>
Total Residential Vacant Lots, Potential New Lots + ADUs	1,208
Total Commercial Vacant Lots, Potential New Lots	78
Total Additional Residential and Commercial Lots at Build-Out	1,286

The increase in the number of new residential and commercial lots will have a corresponding increase in the number of new water service connections.

Table 9 – Potential New Residential and Commercial Connections

<u>Property Type</u>	<u>Connections</u>
Current Residential Connections	1,420
Potential New Residential Connections	1,208
Potential Total Residential Connections at Build-Out	2,628
Current Commercial Connections	96
Potential New Commercial Lots	78
Potential New Commercial Connections ¹	156
Potential Total Commercial Connections at Build-Out	252
Total Residential and Commercial Connections at Build-Out	2,880

¹ Commercial zoning allows 2 units per lot by right. As such, the number of connections is calculated by multiplying the number of new lots by 2 connections per lot.



3.2 Water Service Population

3.2.1 Residential Service Area Population

The increase in the number of connections will result in an increase in residential service area population over the course of the entire build-out timeframe, as shown in the following Table:

Table 10 – Residential Service Area Population Build-Out Summary

Current Residential Service Area Population	3,323
Potential New Residential Connections from Vacant and New Lots	386
Potential New Residential Connections from ADUs	822
Potential New Residential Population at Build-Out *	3,369
Potential Total Residential Service Area Population at Build-Out	6,692
Percentage Increase at Build-Out	101%

* Average household size is 2.34 persons per household (Based on 2022 US Census Bureau Data-ACS).
ADUs are estimated to be 3 persons per ADU.

3.3 Current and Projected Water Demand

3.3.1 Residential Demand

Table 11 – Residential Current and Projected Residential Demand

<u>Demand</u>	<u>Gallons/Day</u>	<u>Gallons/Year</u>
Average Daily Demand (FY 2022)	130,987	47,810,255
Additional Daily Demand at Build-Out *	132,748	48,453,040
Average Daily Demand at Build-Out *	263,735	96,263,295
Maximum Daily Demand (FY 2022) **	261,974	
Maximum Daily Demand at Build-Out **	527,470	

* FY 2022 usage of 39.4 gallons per capita per day

** Estimated Maximum Daily Demand = Average Daily Demand x 2.0 gpd = gallons per day



3.3.2 Commercial Demand

Table 12 – Commercial Current and Projected Demand

Number of Commercial Users		
Current Commercial Users (FY 2022)	96	
Potential New Commercial Connections	156	
Commercial Connections at Build-Out	252	
Commercial Demand		
<u>Demand</u>	<u>Gallons/Day</u>	<u>Gallons/Year</u>
Commercial Demand (FY 2022)	11,536	4,210,786
Average Commercial Demand Per Existing User	120	43,862
Average Commercial Demand Per New User *	92	33,652
Additional Commercial Demand at Build-Out	14,383	5,249,640
Total Commercial Demand at Build-Out	25,919	9,460,426

* New commercial demand assumes residential units constructed in the Commercial zone, with 2 units per lot. As such, a residential demand of 92 gpd/connection is used instead of the commercial demand of 120 gpd/connection.

3.3.3 Governmental Demand

Table 13 – Governmental Current and Projected Demand

Commercial Demand		
<u>Demand</u>	<u>Gallons/Day</u>	<u>Gallons/Year</u>
Governmental Demand (FY 2022)	5,109	1,864,804
Additional Governmental Demand at Build-Out	0	0
Total Governmental Demand at Build-Out	5,109	1,864,804



3.4 Comparison of Capacity and Demand

Table 14 – Comparison of Capacity and Demand (gallons per day)

Total Demands (gallons per day)		
<u>Demand Type</u>	<u>Current Demand</u>	<u>Demand at Build-Out</u>
Residential Average Daily Demand	130,987	263,735
Commercial Daily Demand	11,536	25,919
Governmental Daily Demand	5,109	5,109
Total Average Daily Demand	147,632	294,763
Maximum Daily Demand *	295,265	589,526
Capacity (gallons per day)		
North Pond Capacity	185,000	
Well JR-1 Capacity **	24,000 to 48,000	
JWD System Capacity (North Pond & Well JR-1)	209,000 to 233,000	
Water Treatment Facility Capacity	500,000	

* Estimated Maximum Daily Demand = Average Daily Demand x 2.0

** Well JR-1 is only used when the JWD water treatment plant is operating and has a daily permitted max flow of 50,000 GPD.



3.5 Build-Out Over Time

The information below outlines the current annual population growth as projected by the Town of Jamestown that was used by Pare for future water use projections. These projections were also the basis for use in the 5-year and 20-year water use planning projections in the latest 5-year update to the Jamestown Water Supply System Management Plan (WSSMP).

Annual estimates include that each year there will be approximately 4.0 vacant lots and 5.5 sub-dividable lots are used for new home construction which includes condominiums in the commercial zone. As a result, yearly estimates suggest that the Jamestown population will grow by 23 people (2.34 persons per household) with the development of vacant and non-vacant developable sub-dividable properties.

Annual ADUs are estimated based on 12 new dwelling units will be constructed with half of the dwelling units being one-bedroom and the other half of the dwelling units being two-bedroom. Each year estimates that the Jamestown population will grow by 36 people (two people per bedroom) with the construction of ADUs alone. In total, each year there is an estimated population growth of 59 people in Jamestown. The table below depicts the build-out over time based on this information.

Commercial water usage for the 5-year and 20-year planning periods were projected to increase by five (5) new commercial connections each year.

Table 15 – Projected Population Growth from New Development

<u>Year</u>	<u>Vacant Lots</u>	<u>Subdividable Lots</u>	<u>ADUs</u>	<u>Total</u>
1-Year	4.0 (9)	5.5 (13)	12 (36)	21.5 (58)
5-Year	20 (47)	28 (64)	60 (180)	108 (291)
20-Year	80 (187)	110 (257)	240 (720)	430 (1,165)
Full Build-Out	99 (232)	287 (672)	822 (2,466)	1,208 (3,369)
Time to Full Build-Out	25 years	52 years	69 years	--

* Values in parenthesis estimate the population growth for each housing category.



3.6 Bedroom Count Analysis

As an alternate analysis, Pare has determined that the current housing stock could support an additional 5,219 people (based on the number of existing bedrooms) for a potential total of 8,542 people. Jamestown is currently experiencing an influx of population in the summer months which is evident in their peak summer demand.

This calculation is based on our understanding that there are currently 4,271 bedrooms in the service area and an estimated occupancy of 2 persons per bedroom. This is a theoretical upper limit of population based on the number of existing bedrooms and does not account for the feasibility or likelihood of such an increase.

Table 16 – Residential Service Area Population – Existing Housing

Current Residential Service Area Population (based on Census data) *	3,323
Potential Residential Service Area Population (based on Bedroom Count)	8,542
Percentage Increase in Population	157%

* Census data includes only full-time residents; seasonal population is greater.



Section 4 – Conclusions

Currently, water from the Jamestown production sources (North Pond and Well JR-1) can produce a maximum of approximately 233,000 gallons per day. As a result, the current water system can meet the average daily demand (ADD) of 147,632 GPD of flow.

However, the current system does not produce enough water to meet the maximum daily demand (MDD) of 295,265 GPD of flow. There are currently seasonal flows during the summer months where population is at its peak and these flows can be as high as 350,000 GPD, which far exceeds the current system capacity.

Using the data forecasted in the tables above, the average daily demand at final build-out (294,763 GPD) suggests that the JWD system capacity will not have enough water to support the average daily demand at full build-out within the existing geographic area analyzed in this report.

Based on the limitations of supply and the projected growth, it would not be prudent to consider any expansion of the water district, without developing additional supply and/or managing demand in a significant way. Strategies for increasing supply and managing demand can be found in the Water Supply System Management Plan (WSSMP).



APPENDICES



APPENDIX A

GIS MAPPING AND DATA TABLES

Rural Vacant Residential Properties

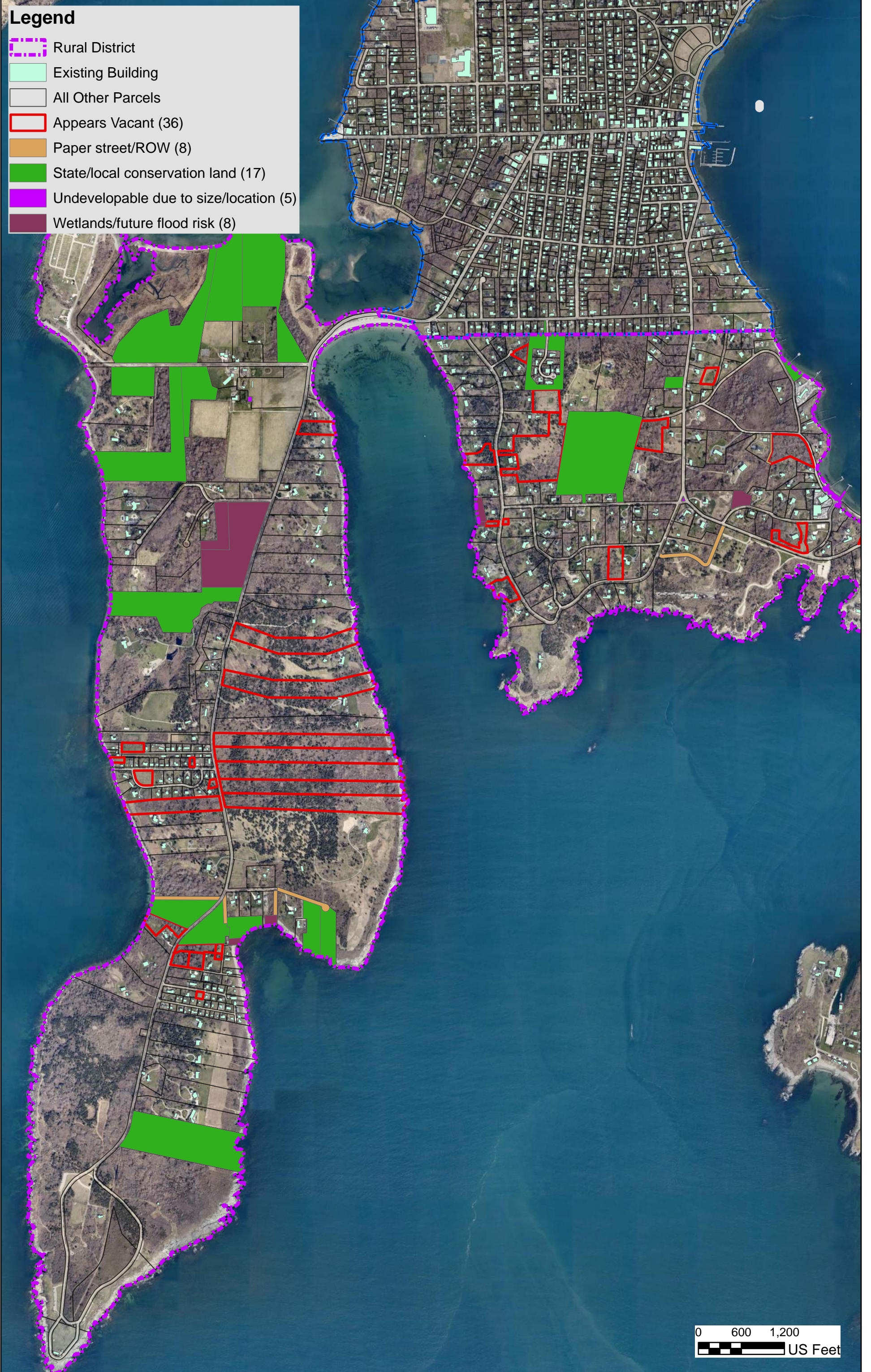

Rural Vacant Residential Properties

OBJEC TID	MSPARCELID	MSAREA CFT	ZONE	Min Lot Size	Develop able	Developa ble Vacant Lots	Excess Developa ble Area (SF)	Excess Developab le Area x 85% (SF)	Potential New Lots by Subdivision	Potential New ADUs from New Lots
200	10-108	34570	RR-80	80000	no	0	0	0	0	0
212	10-121	139745	RR-80	80000	yes	1	59745	50783	0	0
213	10-122	50614	RR-80	80000	yes	1	0	0	0	0
231	10-151	5744	RR-80	80000	yes	1	0	0	0	0
233	10-154	73542	RR-80	80000	yes	1	0	0	0	0
235	10-156	90901	RR-80	80000	yes	1	10901	9265	0	0
236	10-157	1141431	RR-80	80000	no	0	0	0	0	0
237	10-16	186801	RR-80	80000	yes	1	106801	90781	1	1
239	10-18	11547	RR-80	80000	no	0	0	0	0	0
246	10-26	52183	RR-80	80000	no	0	0	0	0	0
254	10-35	61378	RR-80	80000	yes	1	0	0	0	0
268	10-53	80373	RR-80	80000	yes	1	373	317	0	0
272	10-57	6145	RR-80	80000	no	0	0	0	0	0
292	10-83	151362	RR-80	80000	yes	1	71362	60657	0	0
296	10-88	7585	RR-80	80000	no	0	0	0	0	0
299	10-92	82705	RR-80	80000	yes	1	2705	2299	0	0
300	10-94	495371	RR-80	80000	yes	1	415371	353066	4	4
311	11-22	240915	RR-80	80000	no	0	0	0	0	0
313	11-24	3776	RR-80	80000	no	0	0	0	0	0
327	11-37	90180	RR-80	80000	yes	1	10180	8653	0	0
331	11-41	147028	RR-80	80000	no	0	0	0	0	0
336	11-46	835619	RR-80	80000	no	0	0	0	0	0
340	11-5	645370	RR-80	80000	no	0	0	0	0	0
344	11-57	710493	RR-80	80000	no	0	0	0	0	0
345	11-58	506330	RR-80	80000	no	0	0	0	0	0
346	11-59	828418	RR-80	80000	no	0	0	0	0	0
348	11-7	243165	RR-80	80000	no	0	0	0	0	0
362	12-111	13107	R-40	40000	yes	1	0	0	0	0
363	12-112	7653	R-40	40000	yes	1	0	0	0	0
370	12-120	9345	R-40	40000	yes	1	0	0	0	0
375	12-137	238751	RR-80	80000	no	0	0	0	0	0
376	12-138	113637	RR-80	80000	no	0	0	0	0	0
377	12-139	23090	RR-80	80000	no	0	0	0	0	0
378	12-140	14186	R-40	40000	yes	1	0	0	0	0
389	12-155	8727	R-40	40000	yes	1	0	0	0	0
401	12-180	12101	R-40	40000	yes	1	0	0	0	0
410	12-190	46353	R-40	40000	yes	1	6353	5400	0	0
418	12-201	390711	RR-80	80000	yes	1	310711	264104	3	3
425	12-208	497638	RR-80	80000	yes	1	417638	354993	4	4
428	12-211	46373	R-40	40000	yes	1	6373	5417	0	0
429	12-212	648030	RR-80	80000	no	0	0	0	0	0
430	12-213	516216	RR-80	80000	yes	1	436216	370783	4	4
432	12-215	253577	RR-80	80000	yes	1	173577	147540	1	1
434	12-217	159989	RR-80	80000	no	0	0	0	0	0
435	12-218	150638	RR-80	80000	no	0	0	0	0	0
436	12-23	999	RR-80	80000	no	0	0	0	0	0
443	12-3	46047	R-40	40000	yes	1	6047	5140	0	0
444	12-31	571937	RR-80	80000	yes	1	491937	418146	5	5
445	12-37	633460	RR-80	80000	yes	1	553460	470441	5	5
446	12-38	487075	RR-80	80000	yes	1	407075	346014	4	4
447	12-39	509601	RR-80	80000	yes	1	429601	365161	4	4
448	12-4	62837	R-40	40000	yes	1	22837	19411	0	0
456	12-5	212190	RR-80	80000	no	0	0	0	0	0
470	12-68	39142	R-40	40000	yes	1	0	0	0	0
479	12-82	15863	R-40	40000	no	0	0	0	0	0

OBJEC TID	MSPARCELID	MSAREA CFT	ZONE	Min Lot Size	Develop able	Developa ble Vacant Lots	Excess Developa ble Area (SF)	Excess Developab le Area x 85% (SF)	Potential New Lots by Subdivision	Potential New ADUs from New Lots
481	12-84	90711	RR-80	80000	yes	1	10711	9105	0	0
497	13-32	850038	RR-80	80000	no	0	0	0	0	0
3344	9-529	210514	R-40	40000	no	0	0	0	0	0
3420	9-630	39592	R-40	40000	no	0	0	0	0	0
3499	9-737	33467	R-40	40000	yes	1	0	0	0	0
3523	9-773	31752	R-40	40000	no	0	0	0	0	0
3558	9-816	42355	R-40	40000	yes	1	2355	2002	0	0
3596	9-860	117136	R-40	40000	yes	1	77136	65565	1	1
3632	9-743	4084	RR-80	80000	no	0	0	0	0	0
3635		11378	RR-80	80000	yes	1	0	0	0	0
3671	Median	1368	RR-80	80000	no	0	0	0	0	0
3676	Paper Street	64778	RR-80	80000	no	0	0	0	0	0
3678	Paper Street	41485	RR-80	80000	no	0	0	0	0	0
3690	Paper Street	18883	RR-80	80000	no	0	0	0	0	0
3698	Paper Street	16977	RR-80	80000	no	0	0	0	0	0
3707	Paper Street	46200	RR-80	80000	no	0	0	0	0	0
3726	ROW	9211	RR-80	80000	no	0	0	0	0	0
3727	ROW	929	R-40	40000	no	0	0	0	0	0
3728	ROW	1205	R-40	40000	no	0	0	0	0	0
						36			36	36

Summary	
Developable Vacant Lots	36
Potential New Lots by Subdivision	36
Potential New ADUs from New Lots	36
TOTAL	108

Urban Vacant Residential Properties

Legend

- Urban Water Sewer District
- Existing Building
- Flood risk or restricted by wetlands (8)
- Appears vacant (26)
- Local Conservation Land (1)
- Local Conservation Land, Flood risk or restricted by wetlands (21)
- Paper street (11)
- Paper street, Flood risk or restricted by wetlands (2)
- Undevelopable due to size or existing use (1)
- Undevelopable due to size or existing use, Flood risk or restricted by wetlands (7)
- Driveway (1)
- All Other Parcels



Urban Vacant Residential Properties

OBJEC TID	MSPARCELID	MSAREA CFT	ZONE	Min Lot Size	Develop able	Developa ble Vacant	Excess Developa ble Area	Excess Developab le Area x	Potential New Lots by Subdivision	Potential New ADUs
4	8-183	15810	R-20	20000	no	0	0	0	0	0
5	8-198	54282	R-20	20000	no	0	0	0	0	0
6	8-20	8763	R-20	20000	no	0	0	0	0	0
7	8-248	28123	R-20	20000	yes	1	8123	6904	0	0
8	8-28	22978	R-20	20000	no	0	0	0	0	0
9	8-282	20513	R-20	20000	no	0	0	0	0	0
10	8-301	51194	R-20	20000	no	0	0	0	0	0
11	8-338	45054	R-20	20000	no	0	0	0	0	0
12	8-340	20446	R-20	20000	yes	1	446	379	0	0
13	8-367	38711	R-20	20000	no	0	0	0	0	0
14	8-376	23756	R-20	20000	no	0	0	0	0	0
15	8-377	18784	R-20	20000	no	0	0	0	0	0
16	8-379	390	R-20	20000	no	0	0	0	0	0
17	8-389	43555	R-20	20000	no	0	0	0	0	0
18	8-429	9762	R-20	20000	yes	1	0	0	0	0
19	8-520	29314	R-20	20000	no	0	0	0	0	0
23	8-611	6195	R-20	20000	yes	1	0	0	0	0
25	8-637	7858	R-20	20000	yes	1	0	0	0	0
27	8-776	18286	R-20	20000	yes	1	0	0	0	0
28	8-788	29388	R-20	20000	yes	1	9388	7979	0	0
29	8-803	8308	R-20	20000	yes	1	0	0	0	0
30	8-825	6578	R-20	20000	no	0	0	0	0	0
31	8-829	19995	R-20	20000	yes	1	0	0	0	0
32	8-872	28307	R-20	20000	yes	1	8307	7061	0	0
33	8-881	19995	R-20	20000	yes	1	0	0	0	0
34	8-883	18955	R-20	20000	yes	1	0	0	0	0
35	8-887	18293	R-20	20000	yes	1	0	0	0	0
40	9-316	30129	R-20	20000	yes	1	10129	8610	0	0
41	9-318	82051	R-20	20000	no	0	0	0	0	0
47	9-371	16640	R-20	20000	no	0	0	0	0	0
48	9-372	5061	R-20	20000	no	0	0	0	0	0
49	9-377	9674	R-20	20000	no	0	0	0	0	0
50	9-384	18003	R-20	20000	no	0	0	0	0	0
51	9-385	49438	R-20	20000	no	0	0	0	0	0
52	9-386	16248	R-20	20000	no	0	0	0	0	0
53	9-389	5586	R-20	20000	no	0	0	0	0	0
55	9-393	5265	R-20	20000	no	0	0	0	0	0
56	9-395	26505	R-20	20000	no	0	0	0	0	0
57	9-399	5269	R-20	20000	no	0	0	0	0	0
58	9-404	27788	R-20	20000	no	0	0	0	0	0
59	9-411	15428	R-20	20000	no	0	0	0	0	0
62	9-435	9379	R-20	20000	yes	1	0	0	0	0
66	9-677	9350	R-20	20000	no	0	0	0	0	0
68	9-8	52723	R-20	20000	no	0	0	0	0	0
69	9-818	40854	R-20	20000	no	0	0	0	0	0
70	9-819	24612	R-20	20000	no	0	0	0	0	0
71	9-820	28470	R-20	20000	no	0	0	0	0	0
75	8-888	20053	R-20	20000	yes	1	53	45	0	0
78	Paper Street	28743	R-20	20000	no	0	0	0	0	0
79	Paper Street	7948	R-20	20000	no	0	0	0	0	0
80	Paper Street	5407	R-20	20000	no	0	0	0	0	0
81	Paper Street	6879	R-20	20000	no	0	0	0	0	0
82	Paper Street	18796	R-20	20000	no	0	0	0	0	0
83	Paper Street	38294	R-20	20000	no	0	0	0	0	0
84	Paper Street	5256	R-20	20000	no	0	0	0	0	0
85	Paper Street	18938	R-20	20000	no	0	0	0	0	0

86	Paper Street	9028	R-20	20000	no	0	0	0	0	0
88	Paper Street	40405	R-20	20000	no	0	0	0	0	0
39	9-289	26254	R-40	20000	no	0	0	0	0	0
42	9-352	10820	R-40	20000	no	0	0	0	0	0
67	9-733	31542	R-40	20000	no	0	0	0	0	0
2	8-155	11702	R-8	8000	yes	1	3702	3147	0	0
20	8-526	9162	R-8	8000	yes	1	1162	988	0	0
21	8-560	10291	R-8	8000	yes	1	2291	1948	0	0
26	8-753	47673	R-8	8000	yes	1	39673	33722	4	0
36	9-103	5759	R-8	8000	yes	1	0	0	0	0
37	9-120	5823	R-8	8000	yes	1	0	0	0	0
38	9-184	11171	R-8	8000	yes	1	3171	2695	0	0
43	9-353	6532	R-8	8000	no	0	0	0	0	0
46	9-361	2105	R-8	8000	no	0	0	0	0	0
61	9-421	8376	R-8	8000	no	0	0	0	0	0
64	9-538	21358	R-8	8000	no	0	0	0	0	0
72	9-823	8868	R-8	8000	no	0	0	0	0	0
73	9-828	13077	R-8	8000	no	0	0	0	0	0
74	9-865	8394	R-8	8000	yes	1	394	335	0	0
76	Paper Street	19730	R-8	8000	no	0	0	0	0	0
87	Paper Street	7765	R-8	8000	no	0	0	0	0	0
89	ROW	2466	R-8	8000	no	0	0	0	0	0
						23			4	0

Summary	
Developable Vacant Lots	23
Potential New Lots by Subdivision	4
Potential New ADUs from New Lots	0
TOTAL	27

Rural Non-Vacant Subdividable Residential Properties

Legend

 Rural District

 Existing Building

Zone, # of Lots, Subdivision Status (52 total)

 R-40, 7 Lots >80,000sf and Subdividable

 RR-80, 45 Lots >160,000sf and Subdividable

 All Other Parcels

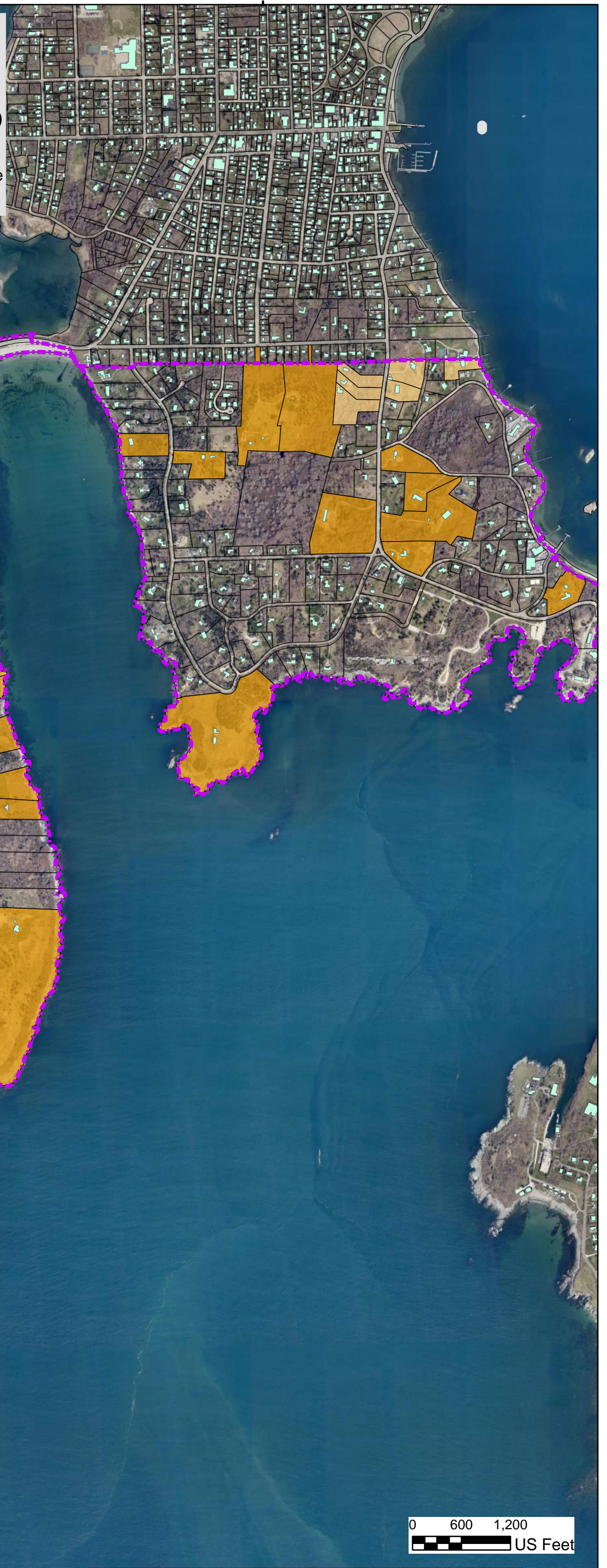

0 600 1,200
 US Feet

Rural Non-Vacant Subdividable Residential Properties

OBJECTID	MSPARCEL ID	MSAREA CFT	ZONE	Min Lot Size (SF)	Excess Area (SF)	Excess Area x 85% (SF)	Potential New Lots by Subdivision	Potential New ADUs from New lots
1173	10-10	172314	RR-80	80000	92314	78467	0	0
1203	10-14	179392	RR-80	80000	99392	84483	1	1
1210	10-15	538649	RR-80	80000	458649	389852	4	4
1232	10-33	165246	RR-80	80000	85246	72460	0	0
1253	10-59	1163042	RR-80	80000	1083042	920586	11	11
1262	10-70	194898	RR-80	80000	114898	97664	1	1
1270	10-82	177543	RR-80	80000	97543	82912	1	1
1272	10-84	524449	RR-80	80000	444449	377782	4	4
1283	11-10	212952	RR-80	80000	132952	113009	1	1
1285	11-12	322310	RR-80	80000	242310	205963	2	2
1286	11-15	284316	RR-80	80000	204316	173669	2	2
1287	11-18	299677	RR-80	80000	219677	186725	2	2
1288	11-2	205824	RR-80	80000	125824	106950	1	1
1289	11-21	400080	RR-80	80000	320080	272068	3	3
1293	11-25	262383	RR-80	80000	182383	155026	1	1
1294	11-26	361887	RR-80	80000	281887	239604	2	2
1300	11-31	240103	RR-80	80000	160103	136088	1	1
1313	11-60	400510	RR-80	80000	320510	272433	3	3
1314	11-45	1601391	RR-80	80000	1521391	1293182	16	16
1318	11-49	257142	RR-80	80000	177142	150571	1	1
1320	11-51	299672	RR-80	80000	219672	186721	2	2
1321	11-55	473742	RR-80	80000	393742	334681	4	4
1322	11-56	624442	RR-80	80000	544442	462776	5	5
1398	12-202	768249	RR-80	80000	688249	585011	7	7
1399	12-203	702476	RR-80	80000	622476	529104	6	6
1400	12-204	572477	RR-80	80000	492477	418606	5	5
1402	12-206	225900	RR-80	80000	145900	124015	1	1
1403	12-207	240050	RR-80	80000	160050	136043	1	1
1405	12-209	610609	RR-80	80000	530609	451018	5	5
1406	12-210	249072	RR-80	80000	169072	143711	1	1
1421	12-29	3250565	RR-80	80000	3170565	2694980	33	33
1428	12-41	854641	RR-80	80000	774641	658445	8	8
1429	12-42	1486492	RR-80	80000	1406492	1195518	14	14
1432	12-47	648288	RR-80	80000	568288	483045	6	6
1433	12-48	313977	RR-80	80000	233977	198880	2	2
1437	12-52	173627	R-40	40000	133627	113583	2	2
1456	12-78	172002	RR-80	80000	92002	78202	0	0
1478	13-37	374886	RR-80	80000	294886	250653	3	3
1479	13-38	406742	RR-80	80000	326742	277730	3	3
1480	13-39	354842	RR-80	80000	274842	233616	2	2
1482	13-40	294334	RR-80	80000	214334	182184	2	2
1483	13-41	389669	RR-80	80000	309669	263218	3	3
1484	13-42	250966	RR-80	80000	170966	145321	1	1
1497	9-340	88501	R-40	40000	48501	41226	1	1
1498	9-341	128143	R-40	40000	88143	74921	1	1

OBJECTID	MSPARCEL ID	MSAREA CFT	ZONE	Min Lot Size (SF)	Excess Area (SF)	Excess Area x 85% (SF)	Potential New Lots by Subdivision	Potential New ADUs from New lots
1499	9-346	84242	R-40	40000	44242	37606	0	0
1506	9-531	158530	R-40	40000	118530	100750	2	2
1507	9-534	572822	RR-80	80000	492822	418899	5	5
1509	9-582	81565	R-40	40000	41565	35330	0	0
1510	9-586	165564	RR-80	80000	85564	72730	0	0
1529	9-829	83930	R-40	40000	43930	37340	0	0
1539	9-859	737931	RR-80	80000	657931	559241	6	6
							188	188

Summary	
Potential New Lots by Subdivision	188
Potential New ADUs from New lots	188
TOTAL	376

Urban Non-Vacant Subdividable Residential Properties

Legend

 Urban Water Sewer District

 Existing Building

Zone, # of Lots, Subdivision Status (106 total)

 R-20, 27 Lots >40,000sf and Subdividable

 R-40, 10 Lots >80,000sf and Subdividable

 R-8, 69 Lots >16,000sf and Subdividable

 All Other Parcels



Urban Non-Vacant Subdividable Residential Properties









OBJECTID	MSPARCEL ID	MSAREA CFT	ZONE	Min Lot Size (SF)	Excess Area (SF)	Excess Area x 85% (SF)	Potential New Lots by Subdivision	Potential New ADUs from New lots	Revised New Lots by Subdivision	Revised New ADUs from New lots
9	8-115	63891	R-20	20000	43891	37307	1	1	1	1
99	8-205	51279	R-8	8000	43279	36787	4	0	4	0
149	8-258	48404	R-20	20000	28404	24144	1	1	0	0
171	8-29	109262	R-20	20000	89262	75872	3	3	0	1
246	8-385	46757	R-20	20000	26757	22743	1	1	1	1
254	8-396	54818	R-20	20000	34818	29595	1	1	0	0
441	8-635	43134	R-20	20000	23134	19664	0	0	0	0
499	8-748	77811	R-20	20000	57811	49139	2	2	0	0
529	8-828	69915	R-20	20000	49915	42428	2	2	1	1
531	8-830	102933	R-20	20000	82933	70493	3	3	3	3
549	8-879	42541	R-20	20000	22541	19160	0	0	0	0
771	9-317	41479	R-20	20000	21479	18258	0	0	0	0
823	9-4	279290	R-20	20000	161290	137096	6	6	6	6
829	9-406	52582	R-20	20000	32582	27694	1	1	0	0
832	9-409	41316	R-20	20000	21316	18119	0	0	0	0
845	9-426	43275	R-20	20000	23275	19784	0	0	0	0
890	9-5	54057	R-20	20000	34057	28948	1	1	1	1
976	9-623	62443	R-20	20000	42443	36077	1	1	0	0
979	9-626	40171	R-20	20000	20171	17145	0	0	0	0
1018	9-674	108932	R-20	20000	88932	75593	3	3	0	0
1040	9-701	40386	R-20	20000	20386	17328	0	0	0	0
1059	9-753	50780	R-20	20000	30780	26163	1	1	1	1
1099	9-809	97147	R-20	20000	77147	65575	3	3	2	3
1100	9-810	124522	R-20	20000	104522	88843	4	4	4	4
1107	9-821	44255	R-20	20000	24255	20617	1	1	1	1
1108	9-822	50137	R-20	20000	30137	25616	1	1	1	1
1118	9-832	77798	R-20	20000	57798	49129	2	2	1	1
155	8-268	87460	R-40	40000	47460	40341	1	1	1	1
157	8-270	90732	R-40	40000	50732	43122	1	1	0	0
158	8-271	108416	R-40	40000	68416	58154	1	1	1	1
159	8-272	133223	R-40	40000	93223	79239	1	1	1	1
341	8-492	116297	R-40	40000	76297	64852	1	1	1	1
450	8-645	122340	R-40	40000	82340	69989	1	1	1	1
755	9-300	96976	R-40	40000	56976	48429	1	1	1	1
778	9-324	134199	R-40	40000	94199	80069	2	2	0	0
866	9-459	166714	R-40	40000	126714	107707	2	2	1	1
1113	9-827	137811	R-40	40000	97811	83139	2	2	2	2
43	8-147	16188	R-8	8000	8188	6960	0	0	0	0
57	8-161	18433	R-8	8000	10433	8868	1	0	0	0
579	9-113	22964	R-8	8000	14964	12720	1	0	2	0
608	9-143	23162	R-8	8000	15162	12888	1	0	1	0
641	9-176	19822	R-8	8000	11822	10048	1	0	1	0
651	9-186	20830	R-8	8000	12830	10905	1	0	1	0
652	9-187	22190	R-8	8000	14190	12062	1	0	1	0
653	9-188	22779	R-8	8000	14779	12563	1	0	1	0
654	9-189	20179	R-8	8000	12179	10352	1	0	1	0
657	9-191	19583	R-8	8000	11583	9846	1	0	1	0
694	9-233	29486	R-8	8000	21486	18263	2	0	2	0
702	9-241	21348	R-8	8000	13348	11346	1	0	1	0
735	9-279	20017	R-8	8000	12017	10215	1	0	1	0
737	9-281	20320	R-8	8000	12320	10472	1	0	1	0
741	9-285	16060	R-8	8000	8060	6851	0	0	0	0
742	9-287	34102	R-8	8000	26102	22187	2	0	2	0
747	9-292	16180	R-8	8000	8180	6953	0	0	0	0
757	9-303	20922	R-8	8000	12922	10984	1	0	1	0
758	9-304	21438	R-8	8000	13438	11422	1	0	1	0
759	9-305	22814	R-8	8000	14814	12592	1	0	1	0

OBJECTID	MSPARCEL ID	MSAREA CFT	ZONE	Min Lot Size (SF)	Excess Area (SF)	Excess Area x 85% (SF)	Potential New Lots by Subdivision	Potential New ADUs from New lots	Revised New Lots by Subdivision	Revised New ADUs from New lots
760	9-306	16115	R-8	8000	8115	6898	0	0	0	0
761	9-307	31879	R-8	8000	23879	20297	2	0	0	0
762	9-308	23448	R-8	8000	15448	13131	1	0	1	0
763	9-309	20112	R-8	8000	12112	10295	1	0	0	0
765	9-311	17970	R-8	8000	9970	8474	1	0	1	0
768	9-314	23886	R-8	8000	15886	13503	1	0	1	0
769	9-315	24661	R-8	8000	16661	14162	1	0	0	0
773	9-319	33754	R-20	20000	13754	11691	0	0	0	0
837	9-418	19639	R-8	8000	11639	9893	1	0	1	0
839	9-420	21155	R-8	8000	13155	11181	1	0	1	0
865	9-458	17713	R-8	8000	9713	8256	1	0	1	0
873	9-47	18058	R-8	8000	10058	8549	1	0	1	0
883	9-490	18226	R-8	8000	10226	8692	1	0	1	0
884	9-491	164843	R-20	20000	144843	123117	6	6	6	6
887	9-495	23598	R-8	8000	15598	13258	1	0	1	0
895	9-505	30000	R-8	8000	22000	18700	2	0	0	0
920	9-545	18154	R-8	8000	10154	8631	1	0	1	0
931	9-562	24391	R-8	8000	16391	13932	1	0	1	0
950	9-59	43627	R-8	8000	35627	30283	3	0	3	0
951	9-590	29812	R-8	8000	21812	18540	2	0	1	0
959	9-60	19525	R-8	8000	11525	9796	1	0	1	0
994	9-65	17342	R-8	8000	9342	7940	0	0	0	0
997	9-654	20523	R-8	8000	12523	10644	1	0	0	0
998	9-655	24542	R-8	8000	16542	14061	1	0	1	0
999	9-656	16178	R-8	8000	8178	6951	0	0	0	0
1003	9-66	21703	R-8	8000	13703	11648	1	0	1	0
1005	9-661	32457	R-20	20000	12457	10589	0	0	0	0
1023	9-68	19487	R-8	8000	11487	9764	1	0	0	0
1029	9-690	25330	R-8	8000	17330	14731	1	0	1	0
1030	9-691	24777	R-8	8000	16777	14261	1	0	1	0
1031	9-692	18332	R-8	8000	10332	8783	1	0	1	0
1044	9-706	16909	R-8	8000	8909	7573	0	0	0	0
1050	9-72	17182	R-8	8000	9182	7805	0	0	0	0
1051	9-730	39193	R-8	8000	31193	26514	3	0	3	0
1054	9-742	25021	R-8	8000	17021	14468	1	0	1	0
1056	9-746	20455	R-8	8000	12455	10587	1	0	1	0
1066	9-768	23957	R-8	8000	15957	13564	1	0	1	0
1073	9-778	18413	R-8	8000	10413	8851	1	0	1	0
1074	9-779	22180	R-8	8000	14180	12053	1	0	1	0
1081	9-786	20049	R-8	8000	12049	10242	1	0	1	0
1090	9-795	25924	R-8	8000	17924	15236	1	0	1	0
1096	9-801	26337	R-8	8000	18337	15586	1	0	1	0
1097	9-805	23727	R-8	8000	15727	13368	1	0	1	0
1105	9-82	19944	R-8	8000	11944	10153	1	0	1	0
1111	9-825	23345	R-8	8000	15345	13043	1	0	1	0
1122	9-853	18632	R-8	8000	10632	9037	1	0	1	0
1124	9-856	18272	R-8	8000	10272	8731	1	0	1	0
1125	9-857	16032	R-8	8000	8032	6827	0	0	0	0
1129	9-862	21076	R-8	8000	13076	11114	1	0	1	0
TOTAL							127	57	99	40

Summary	
Revised New Lots by Subdivision	99
Revised New ADUs from New lots	40
TOTAL	139

Urban Vacant Commercial Properties

Legend

-  Urban Water Sewer District
-  Building
-  Appears vacant (2)
-  Local Conservation Land, Flood risk or restricted by wetlands (1)
-  Paper street (1)
-  Undevelopable due to size or existing use (1)
-  Undevelopable due to size or existing use, Flood risk or restricted by wetlands (3)
-  All Other Parcels

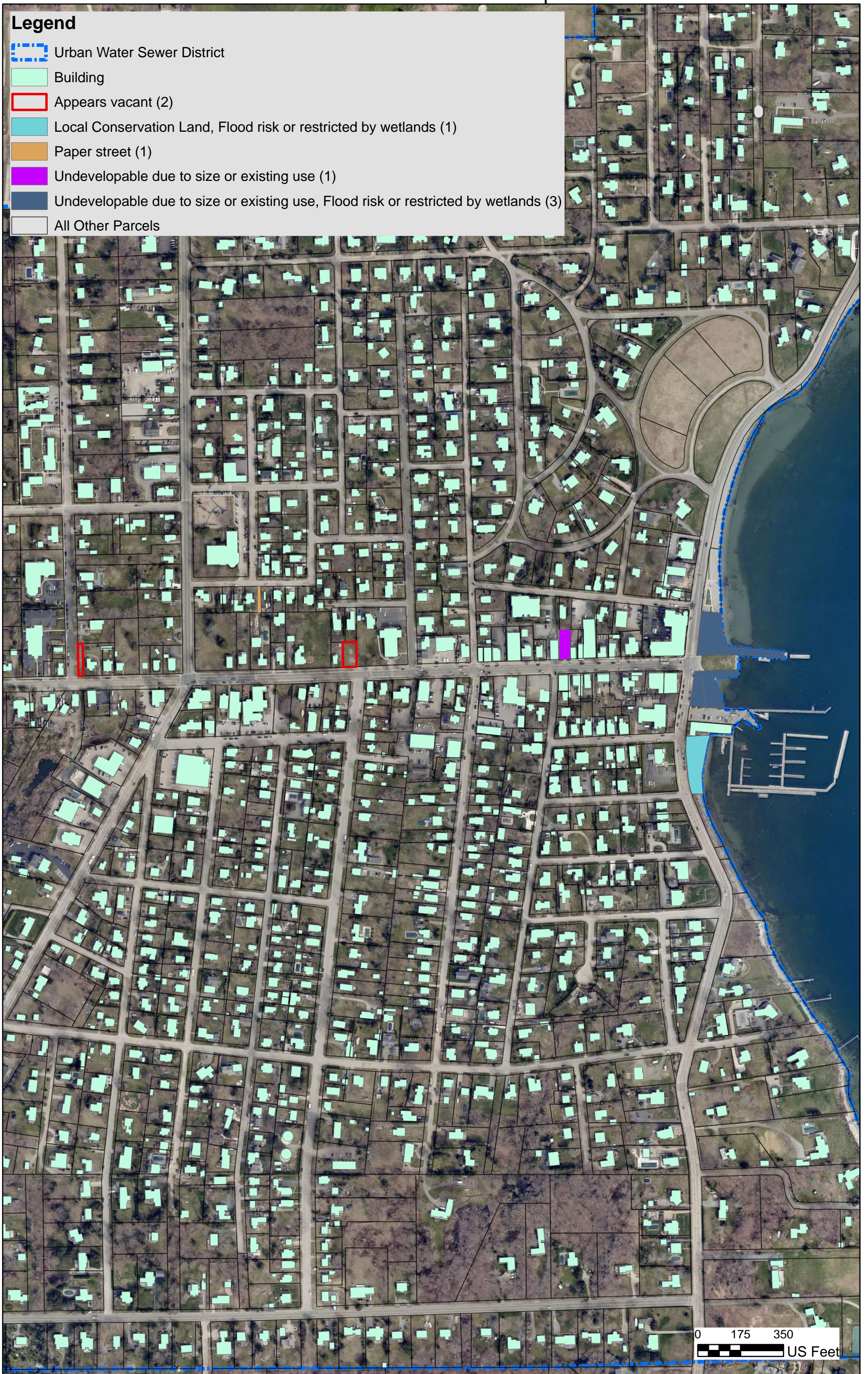

Urban Vacant Commercial Properties

OBJEC TID	MSPARCELID	MSAREA CFT	ZONE	Min Lot Size	Developable	Developable Vacant Lots	Excess Developable Area (SF)	Excess Developable Area x 85% (SF)	Potential New Lots by Subdivision	Potential New ADUs from New Lots
2379	8-122	5610	CD	5000	no	0	0	0	0	0
2772	8-573	5459	CD	5000	no	0	0	0	0	0
3217	9-356	12440	CD	5000	no	0	0	0	0	0
3394	9-595	5749	CD	5000	no	0	0	0	0	0
2803	8-614	2633	CL	8000	no	0	0	0	0	0
3677	Paper Street	1438	CL	8000	no	0	0	0	0	0
2429	8-171	24096	CW	8000	no	0	0	0	0	0
3215	9-354	16135	CW	8000	no	0	0	0	0	0
						0			0	0

Summary

Developable Vacant Lots	0
Potential New Lots by Subdivision	0
Potential New ADUs from New Lots	0
TOTAL	0

Urban Non-Vacant Subdividable Commercial Properties

Legend

 Urban Water Sewer District

 Existing Building

Zone, # Lots, Subdivision Status (57 total)

 CD, 21 Lots >10,000sf and Subdividable

 CL, 33 Lots >16,000sf and Subdividable

 CW, 3 Lots >16,000sf and Subdividable



Urban Non-Vacant Subdividable Commercial Properties

OBJECTID	MSPARCEL ID	MSAREAC FT	ZONE	Min Lot Size (SF)	Excess Area (SF)	Excess Area x 85% (SF)	Calculated New Lots by Subdivision	Calculated New ADUs from New Lots	Revised New Lots by Subdivision	Revised New ADUs from New Lots
4	8-102	43707	CL	8000	35707	30351	3	0	3	0
5	8-106	17571	CL	8000	9571	8135	1	0	1	0
15	8-120	42902	CD	5000	37902	32216	6	0	6	0
19	8-124	49174	CD	5000	44174	37548	7	0	1	0
59	8-163	10812	CD	5000	5812	4940	0	0	1	0
62	8-166	19297	CD	5000	14297	12153	2	0	1	0
268	8-410	23013	CL	8000	15013	12761	1	0	1	0
287	8-433	12982	CD	5000	7982	6785	1	0	1	0
290	8-438	18780	CD	5000	13780	11713	2	0	2	0
294	8-442	23585	CL	8000	15585	13247	1	0	1	0
297	8-445	18789	CL	8000	10789	9171	1	0	1	0
325	8-473	28840	CL	8000	20840	17714	2	0	2	0
337	8-488	38347	CD	5000	33347	28345	5	0	0	0
340	8-490	20663	CL	8000	12663	10763	1	0	1	0
371	8-530	26302	CW	8000	18302	15556	1	0	0	0
419	8-597	17825	CW	8000	9825	8352	1	0	1	0
431	8-616	26241	CL	8000	18241	15505	1	0	0	1
438	8-626	39206	CL	8000	31206	26525	3	0	0	0
468	8-745	19922	CL	8000	11922	10134	1	0	1	0
492	8-775	87254	CL	8000	79254	67366	8	0	0	0
497	8-780	27544	CL	8000	19544	16612	2	0	0	0
505	8-794	20644	CL	8000	12644	10748	1	0	0	0
506	8-795	21936	CL	8000	13936	11845	1	0	0	0
523	8-82	20164	CL	8000	12164	10339	1	0	1	0
543	8-87	22994	CL	8000	14994	12745	1	0	1	0
559	8-92	20024	CL	8000	12024	10221	1	0	1	0
562	8-96	24534	CL	8000	16534	14054	1	0	1	0
563	8-97	23206	CL	8000	15206	12925	1	0	1	0
564	8-98	23835	CL	8000	15835	13460	1	0	1	0
571	9-105	39698	CD	5000	34698	29493	5	0	0	0
576	9-11	102027	CL	8000	94027	79923	9	0	1	0
595	9-13	30327	CL	8000	22327	18978	2	0	0	0
645	9-180	21268	CD	5000	16268	13828	2	0	2	0
648	9-183	35199	CD	5000	30199	25670	5	0	12	0
655	9-19	26949	CL	8000	18949	16107	2	0	0	0
666	9-20	22560	CL	8000	14560	12376	1	0	1	0
668	9-201	12339	CD	5000	7339	6238	1	0	0	0
669	9-207	17585	CD	5000	12585	10697	2	0	2	0
672	9-21	92609	CL	8000	84609	71918	8	0	8	0
682	9-22	59751	CL	8000	51751	43988	5	0	5	0
692	9-23	23147	CL	8000	15147	12875	1	0	1	0
705	9-246	26547	CD	5000	21547	18315	3	0	3	0
706	9-247	10034	CD	5000	5034	4279	0	0	0	0
721	9-263	27207	CD	5000	22207	18876	3	0	0	0
774	9-32	11997	CD	5000	6997	5947	1	0	0	0
779	9-33	13618	CD	5000	8618	7325	1	0	1	0
791	9-36	27512	CD	5000	22512	19135	3	0	0	0
799	9-37	13406	CD	5000	8406	7145	1	0	1	0
804	9-375	27221	CL	8000	19221	16338	2	0	1	0
807	9-38	12347	CD	5000	7347	6245	1	0	1	0
821	9-398	23649	CW	8000	15649	13302	1	0	1	0
962	9-603	17055	CD	5000	12055	10246	2	0	2	0
963	9-605	13993	CD	5000	8993	7644	1	0	1	0
974	9-621	30894	CL	8000	22894	19460	2	0	2	0
980	9-631	11033	CD	5000	6033	5128	1	0	0	0
1101	9-814	25349	CL	8000	17349	14746	1	0	1	0
1149	9-813	29827	CL	8000	21827	18553	2	0	2	0
							126	0	78	1

Summary	
Revised New Lots by Subdivision	78
Revised New ADUs from New Lots	1
TOTAL	79

Urban ADU Residential Properties

Legend

Urban District Residential lots >20,000 square feet (283)



Rural ADU Residential Properties

Legend

Rural District Residential lots >20,000 square feet (275)

