



TOWN COUNCIL MEETING
Jamestown Town Hall
Rosamond A. Tefft Council Chambers
93 Narragansett Avenue
Tuesday, February 21, 2017
6:30 PM

The public is welcome to participate in this Town Council meeting. Open Forum offers citizens the opportunity to clarify an item on the agenda, address items not on the agenda, or comment on a communication or Consent Agenda item. Citizens are welcome to speak to the subject of a Public Hearing, and are allowed to speak at the discretion of the Council President or a majority of Councilors present, or at other times during the meeting, in particular during New or Unfinished Business.

Anyone wishing to speak should use the microphone at the front of the room, stating their name and address for the record; comments must be addressed to the Council, not the audience. It is the Town Council's hope that citizens and Councilors alike will be respectful of each other's right to speak, tolerant of different points of view, and mindful of everyone's time.

I. ROLL CALL

II. CALL TO ORDER, PLEDGE OF ALLEGIANCE

III. TOWN COUNCIL SITTING AS THE BOARD OF WATER AND SEWER COMMISSIONERS

- A) Approval of Minutes; review and discussion and/or potential action and/or vote
 - 1) January 17, 2017 (regular meeting)
- B) Open Forum
 - 1) Scheduled to address
 - 2) Non Scheduled to address
- C) Report of Town Officials: status reports; review and discussion and/or potential action and/or vote
 - 1) Pumping Report
 - 2) Budget to Actual Report
 - 3) Town Projects Report
 - a) Town Wells
 - b) Water Treatment Plant
 - c) Transfer Pumping/Reservoir
 - d) Distribution System
 - e) Wastewater Treatment Facility
- D) Communications; review and discussion and/or potential action and/or vote
 - 1) Letter of Lori and Philip Held re: leak and sewer use charges for 12 Marine Avenue
 - 2) Letter of Alicia Bell and Justin Sirotin re: leak and water and sewer use charges for 32 Green Lane

IV. ACKNOWLEDGEMENTS, ANNOUNCEMENTS, PRESENTATIONS, RESOLUTIONS AND PROCLAMATIONS

V. PUBLIC HEARINGS, LICENSES AND PERMITS

All approvals for licenses and permits are subject to the resolution of debts, taxes and appropriate signatures as well as, when applicable, proof of insurance.

VI. OPEN FORUM

Please note that, under scheduled requests to address, if the topic of the address is available to be put on the agenda, the Council may discuss the issue

- A) Scheduled to address
- B) Non-scheduled to address

VII. COUNCIL, ADMINISTRATOR, SOLICITOR, COMMISSION/COMMITTEE COMMENTS & REPORTS

- A) Administrator's Report: Town Administrator Andrew E. Nota
 - 1) Aging In Place Report

VIII. UNFINISHED BUSINESS

- A) Solar Array Project Updates; review and discussion and/or potential action and/or vote
 - 1) RITBA Solar Array Project: Eric Offenber, RITBA Director of Engineering
 - 2) Other Town Projects
- B) Tax Exemptions for Veterans: requesting the General Assembly enact Enabling Legislation to allow the Town of Jamestown to provide an additional adjustment to the tax exemptions for Veterans; review and discussion and/or potential action and/or vote
 - 1) Resolution No. 2017-02
- C) Amendments to the Jamestown Town Charter: requesting the General Assembly enact Enabling Legislation to allow amendment of the Jamestown Charter as approved by the voters at the November 8, 2016 General Election; review and discussion and/or potential action and/or vote
 - 1) Resolution No. 2017-03
- D) Upcoming Meetings and Sessions – dates and times

IX. NEW BUSINESS

X. ORDINANCES AND APPOINTMENTS, VACANCIES AND EXPIRING TERMS

- A) Ordinances
 - 1) Amendment of the Jamestown Code of Ordinances, Chapter 38 Offenses and Miscellaneous Provisions, Article V. Weapons; two versions of an ordinance amendment to regulate firearm discharges will be considered by the Town Council. One version would prohibit firearm discharges on the entire Conanicut Island, and the

second version would limit firearm discharges on a portion of Conanicut Island. The Council will review, discuss, and potentially amend and/or revise and/or possibly vote to advertise both draft ordinance amendments for public hearing in the *Jamestown Press*.

- B) Appointments, Vacancies and Expiring Terms; view and discussion and/or potential action and/or vote
 - 1) Jamestown Harbor Commission (One vacancy with a three-year term ending date of December 31, 2019); duly advertised; interview conducted
 - a) Letter of interest for appointment
 - i) James Heagney
 - 2) Jamestown Community Playground Renovation Committee (Four Citizen-at-large members); duly advertised; interviews conducted
 - a) Letters of interest for appointment
 - i) Michelle Bush
 - ii) Michael Cabral
 - iii) Lisa Carlisle
 - iv) Betty Kinder
 - v) Bradley Parsons
 - vi) Christina Smith
 - vii) Barbara Szepatowski
 - 3) Jamestown Tax Assessment Board of Review – Alternate (One vacancy with a one-year term ending date of December 31, 2017); duly advertised; no applicants
 - 4) Jamestown Tree Preservation and Protection Committee (Two vacancies with three-year term ending dates of December 31, 2019); duly advertised; no applicants

XI. CONSENT AGENDA

An item on the Consent Agenda need not be removed for simple clarification or correction of typographical errors. Approval of the Consent Agenda shall be equivalent to approval of each item as if it had been acted upon separately.

- A) Adoption of Council Minutes
 - 1) February 6, 2017 (regular meeting)
 - 2) February 6, 2017 (executive session)
- B) Minutes of Boards/Commissions/Committees
 - 1) Jamestown Harbor Commission (01/11/2017)
- C) CRMC Notices
 - 1) Public Notice of application for Assent by 602 East Shore Road Trust to construct and maintain fixed timber pier with fixed terminus and 1200 lb. tender lift extending 116 ft. beyond Mean Low Water at Plat 2 Lot 83, East Passage of Narragansett Bay
 - 2) Public Notice for Proposed Amendments to the Coastal Resources Management Program Procedures Public Hearing on Tuesday, March 28, 2017 at 6:00 p.m., Department of Administration Conference Room A, One Capitol Hill, Providence, with written

comments due by March 10, 2017

D) Abatements/Addenda of Taxes

Total Abatements: \$162,908.26 Total Addenda: \$160,447.35

1) Real Property/Tangible Abatements to 2016 Tax Roll

	<u>Account/Abatement Amount</u>
a)	02-0509-94 \$ 2,163.88
b)	03-1694-00 \$15,220.60
c)	06-0115-50 \$ 3,600.26
d)	11-0119-00 \$ 4,319.44
e)	12-0236-01 \$22,943.19
f)	12-0925-00 \$ 1,900.74
g)	13-1955-50 \$ 103.82
h)	18-0176-00 \$ 564.56
i)	18-0222-00 \$ 772.20
j)	18-0347-15 \$ 3,216.91
k)	18-0640-00 \$34,667.76
l)	18-0742-10 \$17,542.93
m)	18-0817-25 \$ 2,402.11
n)	20-0544-20 \$ 10.47
o)	23-0080-00 \$ 1,113.68
p)	23-0942-00 \$14,469.31
q)	23-0942-00 \$35,302.67
r)	23-1073-30 \$ 2,594.00

2) Real Property/Tangible Addenda to 2016 Tax Roll

	<u>Account/Addenda Amount</u>
a)	03-0131-10 \$ 103.82
b)	03-1112-00 \$35,302.67
c)	04-0231-05 \$34,667.76
d)	04-0863-10 \$15,220.33
e)	06-0168-57 \$ 1,900.74
f)	13-1628-25 \$17,542.93
g)	18-0875-01 \$ 2,594.00
h)	19-0576-00 \$ 2,163.88
i)	19-1224-01 \$ 4,319.44
j)	19-1487-00 \$ 3,216.91
k)	20-0544-20 \$ 2,402.11
l)	20-0587-05 \$22,943.19
m)	23-0110-50 \$14,469.31
n)	26-0053-75 \$ 3,600.26

E) Holiday License Renewals

- 1) Cumberland Farms, Inc. dba: Cumberland Farms Store #1108
Address: 41 North Road
- 2) Islandish, Ltd. dba: Chopmist Charlies
Address: 40 Narragansett Avenue

- F) Private Investigator License Renewal
 - 1) Malcolm Brown dba: South Shore Investigative Agency
Address: 203 Seaside Drive

XII. COMMUNICATIONS, PETITIONS, AND PROCLAMATIONS AND RESOLUTIONS FROM OTHER RHODE ISLAND CITIES AND TOWNS

- A) Communications
 - 1) Letter of Town Planner Lisa W. Bryer, AICP re: Administrative Subdivision between Westwind Drive and the One (1) Foot Strip adjacent to West Wind Drive
 - 2) Memorandum of Robert Rodgers requesting Town Council endorsement of pending legislation that would restrict the carrying of firearms onto school grounds (legislation endorsed by Council in 2016 failed)
 - 3) Request from the Jamestown Philomenian Library Board of Trustees to meet with the Town Council to discuss Library/Town staff communications and interactions
- B) Proclamations and Resolutions from other Rhode Island Cities and Towns
 - 1) Resolution of the Westerly Town Council Opposing the Federal Railroad Administration's Proposal for an Alternative Route for the Northeast Corridor

XIII. AGENDA ITEMS FOR THE NEXT MEETING AND FUTURE MEETINGS

- A) Town Council Rules and Procedures
- B) Town Administrator's Budget Submittal
- C) Golf Course Rehabilitation Project

XIV. EXECUTIVE SESSION

XV. ADJOURNMENT

Pursuant to RIGL § 42-46-6(c) Notice of this meeting shall be posted on the Secretary of State's website and at the Town Hall and the Jamestown Philomenian Library. In addition, notice also may be posted at the Jamestown Police Station and on the Internet at www.jamestownri.gov.

ALL NOTE: This meeting location is accessible to the physically challenged. If communications assistance is needed or other accommodations to ensure equal participation, please call 1-800-745-5555, or contact the Town Clerk at 401-423-9800, via facsimile to 401-423-7230, or email to cfernstrom@jamestownri.net not less than three (3) business days prior to the meeting.

**TOWN OF JAMESTOWN
TOWN COUNCIL MEETING
for
TOWN, WATER AND SEWER MATTERS**

Tuesday, January 17, 2017

A regular meeting of the Jamestown Town Council sitting as the Board of Water and Sewer Commissioners was called to order at the Jamestown Town Hall, Council Chambers, 93 Narragansett Avenue at 6:35 PM by Commission President Kristine S Trocki.

The following members were present:

Mary E. Meagher, Vice-President
Blake A. Dickinson
Eugene B. Mihaly
Michael G. White

Also present were:

Andrew Nota, Town Administrator
Peter D. Ruggiero, Esq., Town Solicitor
Michael Gray PE, Public Works Director
Christina D. Collins, Finance Director
Lisa Bryer, Town Planner
Cheryl Fernstrom, Town Clerk
Denise Jennings, Water and Sewer Clerk

AWARDS, PRESENTATIONS AND ACKNOWLEDGMENTS

(None)

READING AND APPROVAL OF MINUTES

1) 11/07/16 (regular meeting)

Motion was made by Commissioner Meagher, seconded by Commissioner Dickinson to accept the 11/07/16 regular meeting minutes. Motion so voted, 4 in favor; Commissioner Mihaly abstained. Commissioner Mihaly was not yet elected into his position, as the election was held on 11/08/17.

OPEN FORUM

1) Scheduled requests to address:

(None)

2) Non-Scheduled requests to address:

Carol Nelson-Lee of 23 Buoy Street stated that she would like the Commission to consider an island wide ban on water usage and stated that all residents need to have a better understanding of water and its value. Ms. Nelson-Lee noted that many people in the Jamestown Shores area have had problems with their wells during the drought. Ms. Nelson-Lee also encouraged the Town Council to consider and make a commitment to water reuse, specifically for town owned properties. Ms. Nelson-Lee referred to cistern currently located

at the recreation center. Ms. Nelson-Lee suggested that the Town consider option for the future golf course renovations and the library expansion. Commission President Trocki thanked Ms. Nelson-Lee for her input.

REPORT OF TOWN OFFICIALS

1) **Pumping Report:**

The Public Works Director reported the following:

- JR-1 was been taken out of service for the winter.
- Rainfall was up slightly for the month of December, compared to November.
- North Reservoir was @ 38MG, usable storage-60MG. North Reservoir has recovered nicely with the recent rain and he anticipates the reservoir being at capacity by the end of March.
- South Pond is @ 6MG, usable storage-6MG

2) **Town project reports: (See Project Update Report dated January 2017)**

The Public Works Director reported the following:

Treatment Plant:

- He is working with the Town's process controls engineers on relocating all of the motor starters and controls for the Raw Water and Finish Water pumps from the old treatment building to the new treatment building and that he is hoping to have them online by the end of January.

Transfer Pumping/Reservoir:

- Pare Engineering is currently working on the CRMC permitting application for the proposed dam improvements at South Pond.

Wastewater Treatment Facility:

- He has received the final RIPDES permit renewal from RIDEM. The permit is valid for 5 years.
- He has met with Green Mountain Pipeline services to discuss the schedule for the next phase of the slip ling project for the collection system. The work will begin this spring.

The Public Works Director stated that in the past he has offered a tour to the newly elected Town Council/Commission and that he would like to set up a time for a quick tour prior to a Town Council meeting. Council President Trocki stated that the Council would be happy to do a tour of the facilities.

Following clarification of a few items, it was the consensus of the Commission to accept the report, as presented by the Public Works Director.

LETTERS AND COMMUNICATIONS

(None)

UNFINISHED BUSINESS

(None)

NEW BUSINESS

(None)

TOWN BUSINESS

(None)

ADJOURNMENT

There being no further business before the Commission, motion was made by Commissioner White, seconded by Commissioner Meagher to adjourn the meeting at 6:48 PM. So unanimously voted.

Attest:



Denise Jennings
Water and Sewer Clerk

xc: Commission Members (5)
Town Administrator
Town Solicitor
Public Works Director
Town Clerk

Project Update January 2017

WELLS

JR-1, JR-3

- JR-1 has been taken out of service for the winter.

TREATMENT PLANT

- Staff has been working on general equipment maintenance within the treatment plant. During this time of the year we complete our annual maintenance of the filter membranes. Each train is taken off line so that the filter membranes can be removed from the tank and inspected. Filter maintenance is scheduled for the end of January.
- We have been coordinating with our process control engineer on a project to move all of the motor starters and controls for the Raw Water and Finish Water pumps from the former treatment plant building to the new building. The parts have been delivered and we are working with the engineer and electrician to install the equipment. The old equipment for the pumps are obsolete and parts are difficult to obtain in the event of an emergency. The former treatment plant is also at a lower elevation.

TRANSFER PUMPING/RESERVOIR

- Transfer pumping from South Pond has been in operation since November. We are transferring approximately 300,000 gallons per day to the North Reservoir. As you can see the available storage at the north reservoir has increased by 18 million gallons with the rains received and the pumping from south pond.
- The South Pond Dam is an approximately 850-feet in length and consists of an earthen embankment dam section that extends 300 feet across the southern end of the pond and a 550-foot section that consists of an earthen berm or dike section along the westerly side. Pare has been working on the CRMC permitting application for the proposed dam improvement project which include a complete reconstruction of the dike section of the dam. Wetland biologists have been onsite to flag and locate the wetland edges for the proposed project. We will have a budget level estimate for the water and sewer budget discussions this spring.

DISTRIBUTION SYSTEM

South Pond @ 6 MG
Usable Storage, 6 Million Gallons

North Pond @ 38 MG
Usable Storage 60 Million Gallons

- There were no leaks in the distribution system in December 2016.

WASTEWATER TREATMENT PLANT

- The monthly average daily flow at the treatment plant for December was 0.29 million gallons per day. The peak daily flow was 0.37 million gallons. The permitted flow for the monthly average is 0.73 million gallons per day.
- There were no SSO's for the month of December.
- We have received the final RIPDES permit renewal from the RIDEM to authorize the discharge from the Wastewater Treatment Facility to Narragansett Bay. The permit is valid for a period of 5 years. There were no substantial changes to the effluent limitations or monitoring requirements in the new permit issued by RIDEM.
- We met with Green Mountain Pipeline services to discuss the schedule for the next phase of slip lining of our collection system. Work will be completed this spring on the following sections of piping: Knowles Court, Coronado Street, Grinnell Street, Pemberton Avenue, Lawn Avenue, and a section of piping in Shoreby Hill between Longfellow and Whittier.

TOWN OF JAMESTOWN - SEWER DIVISION

BUDGET VS ACTUAL

JULY 2016 - JUNE 2017

YTD Ending January 31, 2017

<u>ACCOUNT NUMBER & DESCRIPTION</u>	<u>ACTUAL BUDGET</u>	<u>PTD EXPENSES</u>	<u>YTD EXPENSES</u>	<u>REMAINING \$</u>	<u>% of BUDGET</u>
OPERATING REVENUES					
40100400 Sewer Line Frontage Assessment	79,501.00	0.00	0.00	79,501.00	0.00%
40100404 New Service Deposits	0.00	0.00	0.00	0.00	#DIV/0!
40100405 Inspection Fees	250.00	0.00	125.00	125.00	50.00%
40100406 Sewer Use Sales	555,000.00	131,991.36	315,856.49	239,143.51	56.91%
40100408 New Service Connection Fees	30,000.00	0.00	3,000.00	27,000.00	10.00%
40100413 Miscellaneous Income	0.00	0.00	0.00	0.00	#DIV/0!
40100414 Dumping Fees	5,000.00	0.00	2,310.00	2,690.00	46.20%
40100415 Investment Income	0.00	0.00	0.00	0.00	#DIV/0!
44000850 Golf Course Allocation	8,000.00	0.00	0.00	8,000.00	0.00%
40100 TOTAL REVENUES	677,751.00	131,991.36	321,291.49	356,459.51	47.41%
OPERATING EXPENSES					
70000100 Public Works Director	22,739.00	1,819.08	13,643.11	9,095.89	60.00%
70000101 Wastewater Super w/Long	69,089.00	5,092.03	38,901.17	30,187.83	56.31%
70000102 Accounting w/Long	37,097.00	3,914.99	22,363.98	14,733.02	60.29%
70000103 Asst. Superintendent w/Long	64,164.00	4,729.06	40,622.58	23,541.42	63.31%
70000104 Plant Operator w/Long	56,277.00	4,226.42	35,283.87	20,993.13	62.70%
70000111 Wastewater Super OT	9,000.00	0.00	1,077.68	7,922.32	11.97%
70000113 Asst. Superintendent OT	9,000.00	381.28	8,406.44	593.56	93.40%
70000114 Plant Operator OT	8,000.00	1,630.27	6,527.40	1,472.60	81.59%
7000 Salaries	275,366.00	21,793.13	166,826.23	108,539.77	60.58%
70009900 Social Security	21,069.00	277.57	11,286.55	9,782.45	53.57%
70009901 Health & Dental	55,825.00	2,906.03	14,115.30	41,709.70	25.28%
70009902 Life Insurance	550.00	0.00	334.80	215.20	60.87%
70009904 Retirement	30,042.00	2,763.09	12,037.01	18,004.99	40.07%
70009906 Worker's Compensation	9,000.00	0.00	9,000.00	0.00	100.00%
Salary Adj	6,000.00	0.00	0.00	0.00	0.00%
70020910 Clothing Allowance	1,500.00	0.00	0.00	1,500.00	0.00%
7000 Benefits	123,986.00	5,946.69	46,773.66	71,212.34	37.72%
7000 TOTAL SALARY & BENEFITS	399,352.00	27,739.82	213,599.89	179,752.11	53.49%
70020001 Power - Electricity	40,000.00	2,871.04	14,723.21	25,276.79	36.81%
70020002 Chemicals	2,500.00	0.00	258.12	2,241.88	10.32%
70020003 Heat	10,000.00	532.75	1,513.27	8,486.73	15.13%
70020004 Water	2,200.00	508.40	1,303.79	896.21	59.26%
70020005 Chlorine	7,000.00	1,365.00	3,689.28	3,310.72	52.70%
70020006 Equipment Maintenance	22,000.00	1,892.95	10,711.50	11,288.50	48.69%
70020007 Solvents, Cleaning, Office Supplies	5,000.00	1,956.44	8,136.08	-3,136.08	162.72%
70020008 Laboratory Supplies	4,500.00	0.00	834.70	3,665.30	18.55%
70020009 Telephone	750.00	57.08	266.17	483.83	35.49%
70020010 Alarm Lines	5,500.00	684.22	2,963.93	2,536.07	53.89%
70020011 Sludge Disposal	40,000.00	3,488.01	17,371.00	22,629.00	43.43%
70020012 Truck Operation & Maintenance	1,000.00	0.00	0.00	1,000.00	0.00%
70020013 Gas - Truck	2,500.00	0.00	127.68	2,372.32	5.11%
70020014 State Mandated Testing	20,000.00	2,567.00	11,093.00	8,907.00	55.47%
70020015 Permit Renewal	0.00	0.00	0.00	0.00	#DIV/0!
70020016 Training	1,000.00	0.00	10.00	990.00	1.00%
70020103 Generator Fuel	0.00	0.00	0.00	0.00	#DIV/0!
70020600 Professional Services	2,000.00	0.00	0.00	2,000.00	0.00%
70020xxx Audit	2,500.00	0.00	0.00	2,500.00	0.00%
7002 Wastewater Treatment Facility	168,450.00	15,922.89	73,001.73	95,448.27	43.34%

TOWN OF JAMESTOWN - SEWER DIVISION**BUDGET VS ACTUAL****JULY 2016 - JUNE 2017****YTD Ending January 31, 2017**

<u>ACCOUNT NUMBER & DESCRIPTION</u>	<u>ACTUAL BUDGET</u>	<u>PTD EXPENSES</u>	<u>YTD EXPENSES</u>	<u>REMAINING \$</u>	<u>% of BUDGET</u>
700300017 Pumping Station #3 (W Ferry)	4,000.00	327.07	1,355.74	2,644.26	33.89%
700300018 Pumping Station #1 (Bayview)	18,500.00	1,611.83	5,569.26	12,930.74	30.10%
700300019 Pumping Station #2 (Hamilton)	10,500.00	796.20	2,610.71	7,889.29	24.86%
700300020 Pumping Station #4 (Maple)	750.00	41.39	162.52	587.48	21.67%
7003 Pumping Stations	33,750.00	2,776.49	9,698.23	24,051.77	28.74%
70040598 Equipment Insurance	4,000.00	0.00	4,000.00	0.00	100.00%
7004 Insurance	4,000.00	0.00	4,000.00	0.00	100.00%
70050021 Maintenance and Cleaning	6,500.00	0.00	1,633.40	4,866.60	25.13%
70050605 West Ferry Extension Notes	5,371.00	0.00	16,601.94	-11,230.94	309.10%
70050xxx Jet Vac Truck Lease	10,703.00	0.00	0.00	10,703.00	0.00%
70050xxx Slip Lining	9,625.00	0.00	0.00	9,625.00	0.00%
7005 Sanitary Sewers, Laterals&Mains	32,199.00	0.00	18,235.34	13,963.66	56.63%
70100.xxx Capital Set Aside	40,000.00	0.00	12,094.29	27,905.71	30.24%
7007 Capital Improvement	40,000.00	0.00	12,094.29	27,905.71	30.24%
TOTAL EXPENSES	677,751.00	46,439.20	330,629.48	341,121.52	48.78%
TOTAL REVENUE	677,751.00	131,991.36	321,291.49	356,459.51	47.41%

Project Update February 2017

WELLS

JR-1, JR-3

- JR-1 has been taken out of service for the winter.

TREATMENT PLANT

- Staff have been working with our process control engineer and electrician to install the new motor starters for the raw water and finish water pumps to operate out of the new treatment plant building. Work will continue in February with pulling wire between the pumps, electrical panel, and the process control panel.

TRANSFER PUMPING/RESERVOIR

- Transfer pumping from South pond to the north reservoir was activated on November 1, 2016 when we received sufficient rainfall where water began to discharge from the spillway at South pond. There were 14 days that we were able to transfer water in November for a total of 4,408,000 gallons. Pumping continued through December for a total of 9,972,800 gallons transferred for the month. The pump was turned off on January 26th for a total of 6,619,900 gallons for the month. A total of 20,997,700 gallons of water was transferred to the North Reservoir over the 3-month period.
- Pare has been working on the CRMC permitting application for the proposed South Pond dam improvement project which includes a complete reconstruction of the dike section of the dam. The application should be ready for submittal in early March.

DISTRIBUTION SYSTEM

South Pond @ 6 MG

Usable Storage, 6 Million Gallons

North Pond @ 45 MG

Usable Storage 60 Million Gallons

- There were no leaks in the distribution system in January.

WASTEWATER TREATMENT PLANT

- The monthly average daily flow at the treatment plant for January was 0.64 million gallons per day. The peak daily flow was 1.29 million gallons. The permitted flow for the monthly average is 0.73 million gallons per day.
- There were no SSO's for the month of January.

- Green Mountain Pipeline services has tentatively scheduled the next phase of slip lining for the end of March. Work will begin with cleaning the piping and completing a closed-circuit TV inspection. The following sections of piping will be slip-lined: Knowles Court, Coronado Street, Grinnell Street, Pemberton Avenue, Lawn Avenue, and a section of piping in Shoreby Hill between Longfellow and Whittier.

	2010	2011	2012	2013	2014	2015	2016	2017
Jan	1.1	4.22	2.49	1.85	3.1	1.22	2.94	2.94
Feb	2.2	3.09	0.93	2.94	4.98	0.86	4.25	4.25
Mar	12.2	1.32	1.64	1.32	5.74	4.53	2.36	2.36
Apr	1.77	4.25	2.24	1.92	4.8	1.47	3.53	3.53
May	1.69	2.32	5.97	3.11	1.27	0.32	2.24	2.24
Jun	4.11	4.4	3.64	7.55	2.86	4.2	0.89	0.89
Jul	2.4	2.01	3.86	2.42	5.93	4.63	2.19	2.19
Aug	2	5.23	3.64	3.98	1.23	2.17	1.88	1.88
Sep	2.4	5.41	2.39	2.13	0.5	3.41	2.42	2.42
Oct	4	7.18	2.33	0.9	3.61	1.31	5.33	5.33
Nov	3.4	4.05	0.58	3.76	1.47	2.27	2.63	2.63
Dec	1.76	2.51	6.28	3.76	3.1	4.2	2.79	2.79
Total	44.8							

RAINFALL

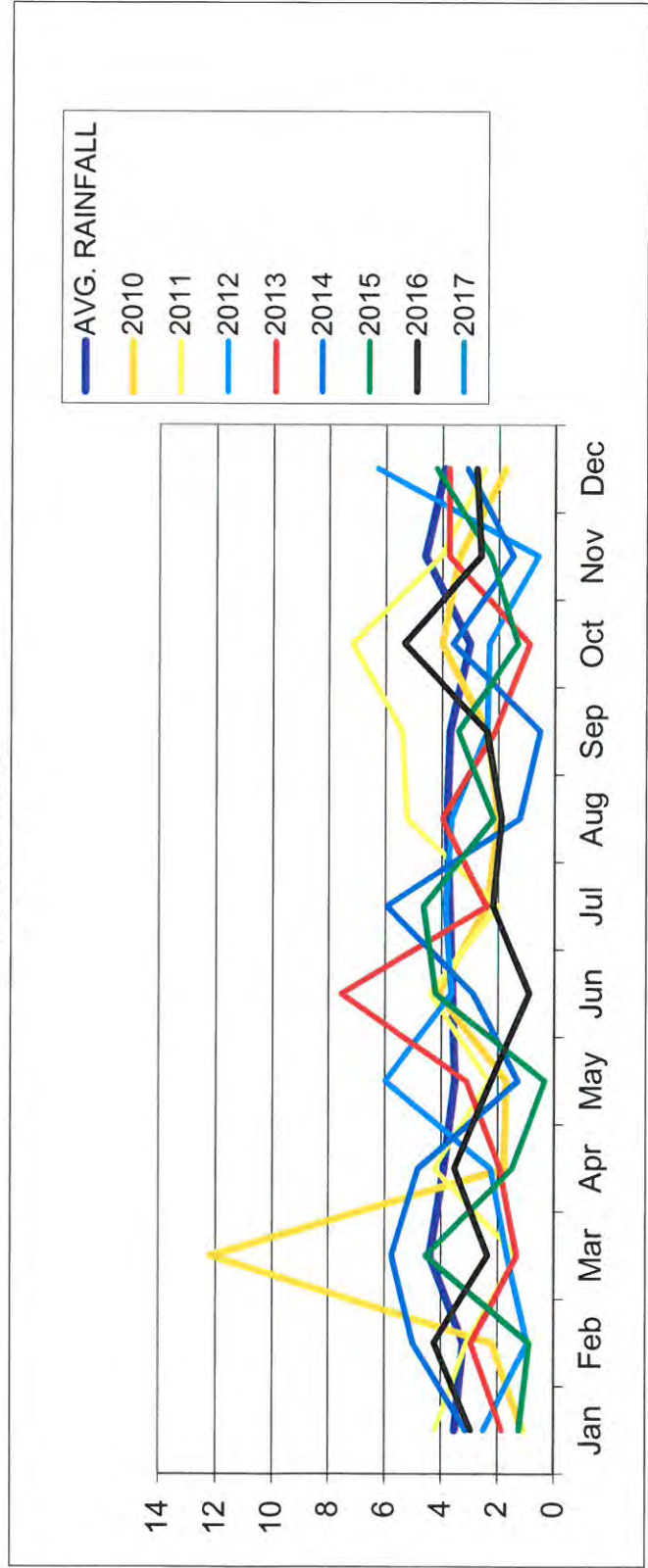

RESERVOIR LEVEL

	1993	2010	2011	2012	2013	2014	2015	2016	2017
Jan	9	60	30	60	42	55	45	46	45
Feb	8	60	52	60	60	60	45	58	58
Mar	5	60	58	58	60	60	60	60	60
Apr	10	60	60	60	60	60	60	60	60
May		60	57	60	55	58	56	55	55
Jun		51	51	54	60	51	51	50	50
Jul		43	43	49	58	55	49	44	44
Aug	9	40	47	43	43	45	44	35	35
Sep	8	35	45	40	40	41	40	23.5	23.5
Oct	5	30	58	38	38	39	33	22	22
Nov		28	60	35	36	34	30	20	20
Dec	10	29	60	42	46	43	44	38	38

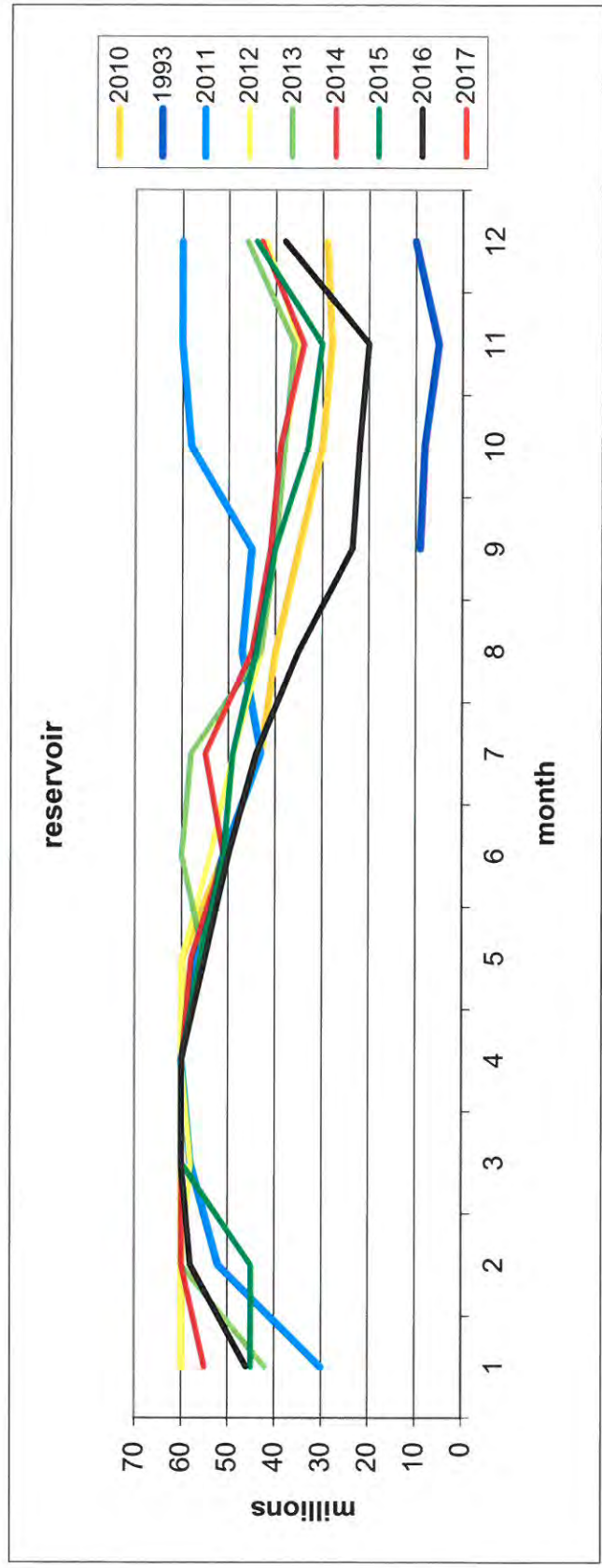



Board of Water and Sewer Commissioners
93 Narragansett Ave.
1st Floor Finance Office
Jamestown, RI 02835

Re: Sewer usage charges for 12 Marine Avenue

January 4, 2017

Dear Board Members,

On December 20, 2016, a leak was discovered in an outdoor shower on our property by a passing neighbor. We contacted the Jamestown Water and Sewer Division about the leak and learned that the meter had last been read on December 9, 2016. We requested a new meter reading to discover the amount of water lost due to the leak. This meter reading was performed on December 22, 2016 and it was determined that 19,243 gallons of water were used during the December 9-22 time frame.

We own the house on 12 Marine Avenue, but reside in Laurel, Maryland. For the last nine years, the Marine Avenue house has only been occupied during the summer months. Because the house has been unoccupied since September 18, 2016 of this year, all water usage from December 9-22 was due to the outdoor leak. The water from the leak went into the yard and subsequently the basement of the house, which also naturally drains back into the yard due to the basement design constructed in 1901.

We understand that we are responsible for the cost of the 19,243 gallons of water lost during this event, but ask that a concession be made for the sewer usage charges since none of the water entered the town sewer system. According to the calculations provided by the Water and Sewer Division, the two sewer usage charges for the leak total \$365.37 (breakdown shown below and in accompanying documents).

We hope that the Board is understanding in this matter and will waive the sewer usage fees, as there was no sewer usage during this event. We would also like to note that the Water and Sewer Division staff have been extremely helpful, for which we are very grateful.

Thank you for your time and consideration,



Lori and Philip Held

1204 Snowden Place

Laurel, MD 20707

Phone: 301-776-2041

Email: LBHELD@yahoo.com

Property: 12 Marine Avenue

Information provided by the Jamestown Water and Sewer Division:

Meter Read 12/09/16	71428
Meter Read 12/22/16	90671
Water usage 12/09 – 12/22	19243

	Unit	Rate	Qtrly Amount
Minimum in Advance	1	\$76.13	\$76.13
Excess Water	14.24	\$8.74	\$124.46
State Surcharge 1	19.24	\$0.11	\$2.03
State Surcharge 2	19.24	\$0.17	\$3.20
Sewer Charge – Usage	19.24	\$12.50	\$240.50
Sewer Debt Flat Fee	1	\$38.02	\$38.02
Sewer Debt Usage Fee	19.24	\$6.49	\$124.87
			\$609.20

93 Narragansett Avenue

Status: Closed

Work Order: WO_6749

Owner Account: 02-003019
Owner Name: HELD, PHILIP S. P.ET
HELD, VIRGINIA
1204 SNOWDEN PL
LAUREL, MD 20707

Parcel ID: 9/481
Location: 12 MARINE AVE

Work Order Type: Re-read
Scheduled Time: 12/22/2016 12:00 AM
Performed by: PAUL
Description: Customers caretaker/friend found an outside shower that sprung a leak and then ran into the basement. The water to the shower has since been turned off. The owner would like to see how much water went through the meter. I will call the owners daughter in law Laurie with status. 301-785-8433

Meter Location:

Account Information:

Account Status: A
Account Type:
Property Type: RESIDENTIAL
Property Use:
District: JAMESTOWN
Business Type: District 1
Section:
Billing Freq :

Meter Information:

Meter Manuf:
Meter Number: 90565165
Meter Size: 5/8
Installation Date: 07/27/2007
ARB Number:
Route Name: Route 002
Read Sequence: 000011
Company Number: 1482838568
Meter Pit Acct: 7 Dials/None
Saving Devices: / /
Backflow Type:
Backflow Date: / /

Read Device Information:

Read Device:
Module Number:
Read Resolution:
Low / High Limit: /
Read Type: Radio

Radio Read Information:

ERT ID:
Tamper 1 & 2: &
Read Date/Time: / / : : AM
Read Mode:
Carrier Freq:

Read History

Billing Roll	Read Type	Read Date	Reading	Consumption
2016-10-01 W/S	ACTUAL	09/09/2016	70593	9368
2016-07-01 W/S	ACTUAL	06/10/2016	61225	1203
2016-04-01 W/S	ACTUAL	03/09/2016	60022	936
2016-01-01 W/S	ACTUAL	12/09/2015	59086	437
2015-10-01 W/S	ACTUAL	09/14/2015	58649	9058

Comments

122216-read was 90671. which went up 19243 gallons since the billing read on 120916 which was 71428.

Signature:

Property Owner

Date

Denise Jennings

From: Jean Gabriele
Sent: Tuesday, December 27, 2016 1:17 PM
To: lbheld@yahoo.com
Cc: Denise Jennings
Subject: FW: water bill

Dear Ms. Held,

The following calculations are based on the reading taken on the 22nd of December. If you have any questions pertaining to this matter, please feel free to contact Denise @ 423-9808.

Jeanie

From: Christina Collins
Sent: Tuesday, December 27, 2016 12:57 PM
To: Jean Gabriele
Cc: Denise Jennings
Subject: water bill

Unit	Rate	Qtrly Amount
1	\$76.13	\$76.13
14.24	\$8.74	\$124.46
19.24	\$0.11	\$2.03
19.24	\$0.17	\$3.20
19.24	\$12.50	\$240.50
1	\$38.02	\$38.02
19.24	\$6.49	\$124.87
		\$609.20

CHRISTINA D. COLLINS
FINANCE DIRECTOR
TOWN OF JAMESTOWN
93 NARRAGANSETT AVE.
JAMESTOWN, RI 02835
ccollins@jamestownri.net
P)401-423-9809
F)401-423-7229

February 12, 2017

ATTN: Denise Jennings and Jamestown Board of Water and Sewer Commission

Re: Plat and Lot Number: 9/239

Location [as listed on our bill]: 32 GREEN LANE (& 34)

Account Number: 06-032014

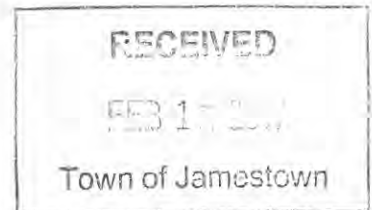

To Whom It May Concern:

We are writing to request your close attention and consideration toward our Water and Sewer Bill for the 4th Quarter of 2016. This bill was the result of a 155,000+ gallon leak of which we were unaware until 12/10/16. We have enclosed a copy of this most recent bill for your direct reference.

On the morning of Saturday, 12/10/16, we noticed two shallow puddles in our front yard, both about 3x3'. There had been no rain or snow for several days but we thought our neighbor may have used a hose at the edge of our property. When the water did not retreat by late afternoon, we began to suspect a leak in our exterior water line, given that it was winter time and there had been no precipitation. We left a voicemail for the Board of Water and Sewer that evening, explaining the puddle and our concerns of a leak. I remember stating that there wasn't much water in the yard, so it didn't feel like an emergency that the police should check on (as per notes on the town website). I stated that we would follow-up on Monday morning if the puddle persisted. It also occurred to us that our consistently strong water pressure had not changed at all inside the house.

On Sunday, 12/11/16, the puddle was still there but only a foot larger in each direction. We began discussing the issue with friends and neighbors and decided to contact our plumber that day. He expressed immediate concern and connected us with K. M. Excavating (Ken Gladding) to survey the issue on Monday morning, 12/12/16 at 8am.

Little did we know that our meter had its routine quarterly reading on Friday, 12/9/16, to the tune of \$5978.25 -- evidence that a dramatic over-usage was clearly present. It should be noted, that no one from the Board of Water and Sewer contacted us that Friday, after a meter reading that was 15 times larger than our standard usage. This reading should have raised a significant red flag that there was a problem that needed immediate attention. We now understand that because we do not have a basement or crawl space, this leak, which appeared 20+ feet from the front of our house, was pumping water into the ground for an unknown amount of time. In the time we've taken to assess this issue and scrutinize the current billing and charges for this leak, we've also realized that approximately half of the Water and Sewer Bill reflects sewer charges -- in this case the great majority of the water never even entered the sewer system, it went directly back to the water table.

For an unknown reason, our water and sewer meter is set-up in a pit at the streetside edge of our lot. We are not able to read our own meter to monitor our water usage in real time. We've been told on several occasions, by several community members and contractors that our house is one of the few properties in the village, along with some on Beavertail, that have meters like ours, out of reach, out of view, in a pit at the street. In fact, until we had this faulty waterline excavated and replaced on 12/13/16, we were not even able to turn off our own water at the meter if we were to detect a problem.

Prior to our discovery of this leak, in September 2016, at the close of the 3rd billing cycle, we received a letter from the Board of Water and Sewer, noting concern of over-usage. The recent history of our house is of paramount importance to this water leak. We have owned this house since November 2013. We bought it as

a side-by-side two family that was clearly in need of tremendous repairs and systems updates. Over a period of three years, we have fully renovated the home, converting it to a single family dwelling with completely new plumbing (inside the house only), and electrical systems as well as significant structural updates. We had moved back into the house in February 2016 at which point we were admittedly unclear on our new water usage as an expanded single family home. In addition, we had a massive stream of guests throughout the summer which we assumed drove up our consumption from our typical 10k gallons up to 20k gallons. Furthermore, we had no visible water leaks in the house or yard and experienced no change in water pressure in the home.

Due to our lack of a basement, our renovation also included the calculated rerouting and relocation of many water lines into our walls and ceiling, specifically so that we will be able to detect and repair any leaks that may occur inside our home in the future. We are experienced home owners who hold great pride in the efficiency of our home including low flow shower heads, high efficiency appliances, and a newly insulated home. We also have no irrigation system, no outdoor water features, and use water extremely conservatively,

As full time residents of Jamestown, we have quickly come to value the interconnected culture of our community. It feels that the Board of Water and Sewer would be taking advantage of well-meaning customers by not following-up after a potential issue has been flagged (Sept. 2016). In this small, tight knit community, it's incredibly frustrating that the Board of Water and Sewer did not in anyway follow up on the initial letter from Sept 2016. Again, we as residents have no ability to read our own water meter and assess our usage in an informed and timely manner. With no visible symptoms, we are not equipped to address a leakage of this type before it turns into a massive issue, wasting valuable water for the town, and driving up our bill.

We would like to have the opportunity to meet with the Board of Water and Sewer directly to discuss how to resolve the charges from our 4th Quarter 2016 bill (\$6364.82). Please advise on the process for setting up such a meeting.

Best Regards,

Alicia Bell and Justin Sirotin
34 Green Lane

The image shows two handwritten signatures in black ink. The top signature is a cursive signature that appears to be 'Alicia Bell'. The bottom signature is a cursive signature that appears to be 'Justin Sirotin'.

Rhode Island

Building an Age-Friendly Community

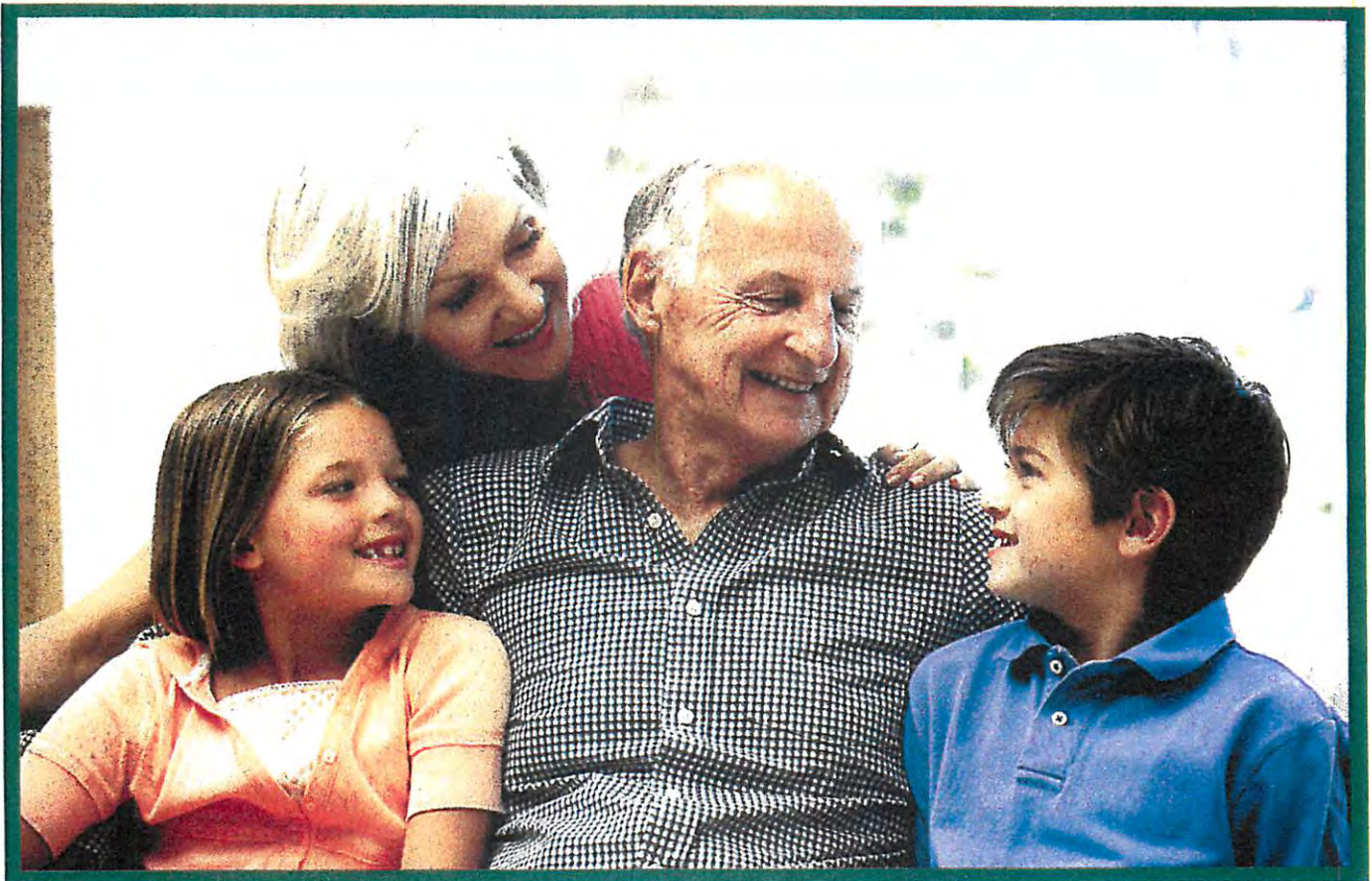

Strategic Plan

December 2016

Building an Age-Friendly Community

Table of Contents

Mission Statement	Page	3
Vision Statement	Page	3
Introduction	Page	3
Communication and Information	Page	4, 5
Transportation	Page	6, 7
Community and Civic Engagement	Page	8, 9
Food Security and Nutrition	Page	10, 11
Economic Security	Page	12, 13
Healthcare Access	Page	14, 15
Outdoor Spaces and Public Buildings	Page	16, 17
Housing	Page	18, 19
Supports to Remain at Home	Page	20, 21

Building an Age-Friendly Community

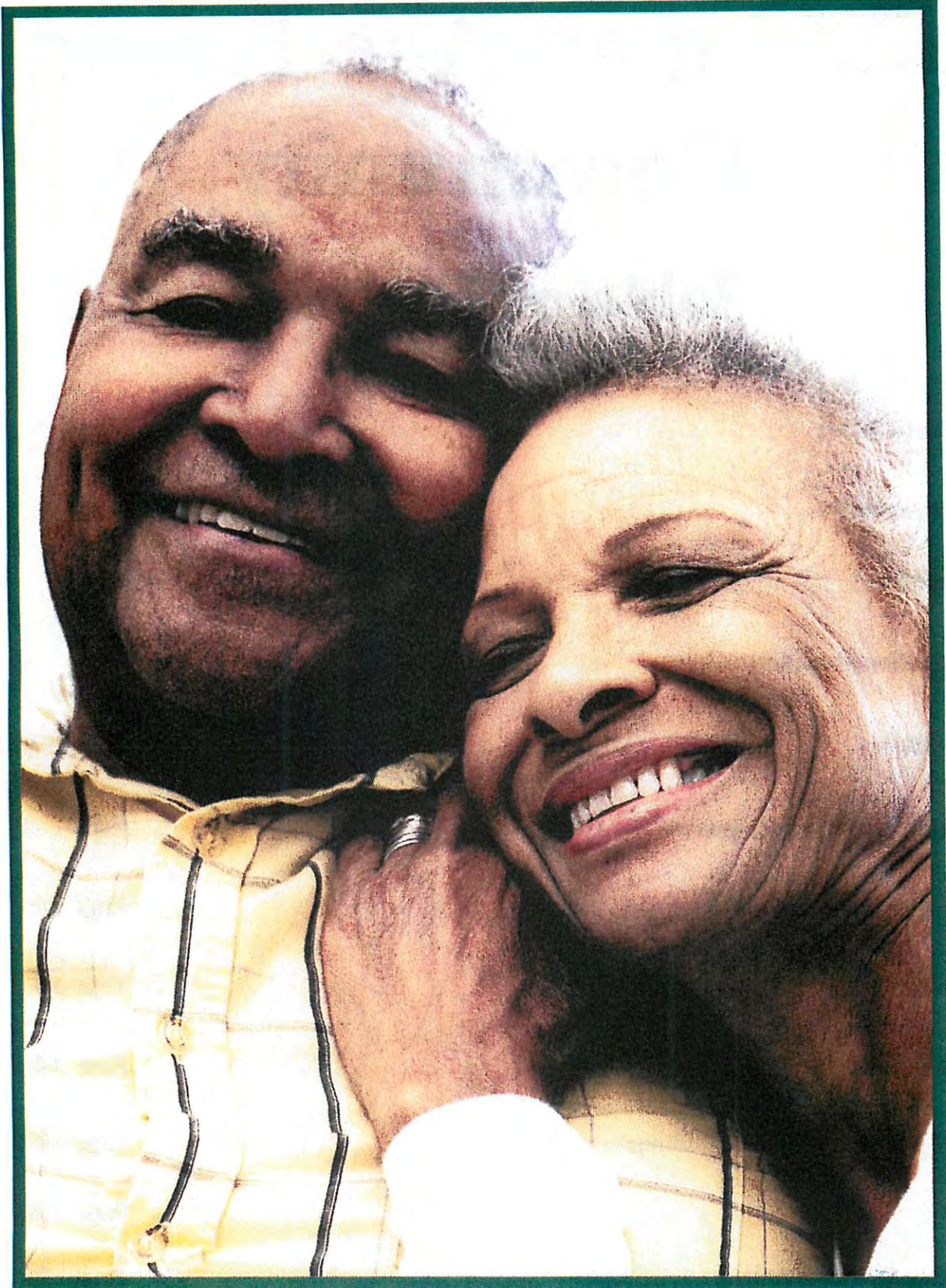

Strategic Plan

Mission Statement

Our mission is to create partnerships and build a community that supports Rhode Islanders as they age. We strive to:

- Provide coordinated services and programs that meet the needs and preferences of older Rhode Islanders and support their lifestyle
- Enhance the quality of life for older adults by providing opportunities for community engagement
- Empower older adults to live life to its fullest

Vision Statement

To build a community that enables Rhode Islanders to live independently with the care, support and resources needed to foster health, well-being, social connectedness and a meaningful life as they age.

Introduction

This strategic plan builds on the work of the Aging in Community Subcommittee of the Long Term Care Coordinating Council which was supported in part with a grant from the Tufts Health Plan Foundation. The Plan targets goals, strategies and actions that address the needs of older adults in Rhode Island and challenges and gaps in services. The objectives are organized according to the World Health Organization dimensions of an age-friendly community. A coalition of stakeholders will be convened and engaged to refine this strategic plan, prioritize objectives and implement strategic actions to build an Age-Friendly Rhode Island. Stakeholders will include older adults, community agencies, healthcare and social service providers, advocacy organizations, academic institutions, faith-based organizations, businesses and state agencies.

Building an Age-Friendly Community

Communication and Information

Challenges and Gaps in Services

Rhode Island has not achieved the goal of meeting a “*No Wrong Door-One Stop*” approach to providing timely and accurate information to its seniors about services and benefits available to them. Dedicated federal funding to support THE POINT/ADRC network, the state’s primary source of information for seniors, has ended, and no state funding currently supports its activities. The state lacks a functional website for THE POINT network. The existing web address says THE POINT site is “under construction” and it has been this way for a number of years. For those middle-income seniors not eligible for most public benefits/programs, Options Counseling is not always available, and counselors may not be adequately trained to offer middle-class consumers and families information and advice about options for keeping seniors at home.

Senior Voices

- **Need for and difficulty in finding information about available service**
Participants were not aware of THE POINT or the services provided
Difficulty with the responsiveness of the Department of Human Services
(phone calls not answered or returned, inaccurate information provided
and a lack of customer service)
- **Information Specialist at the senior centers helpful but not always available**
- **Children and caregivers need information about finances and end-of-life planning**
- **Information available online not always a preferable channel of communication**

Objectives

- To make information about services and programs more accessible to older adults
- To assist older adults to become more engaged in their communities

Strategic Actions

1. **Create an interactive web site for THE POINT**
2. **Enact a specific ADRC enabling statute with a state appropriation**
3. **Co-locate staff from the Department of Human Services long term care eligibility offices in POINT programs**
4. **Provide Options Counseling staff with permissions to access to Medicaid client information**
5. **Work with local newspapers to create a dedicated column on information for older adults**
6. **Use traditional media (radio and television) to provide information to older adults**
7. **Develop an “Angie’s List” like resource for older adults – hard copy and online**
8. **Encourage cities and towns, businesses, and health service entities to sponsor programs that are open to the general public and cover topics important for seniors, such as Medicaid eligibility, financial planning, legal services, reverse mortgages, end-of-life, etc.**
9. **Create a “Building an Age-Friendly Rhode Island” website just for older adults**
10. **Sponsor “Social Service Malls” where multiple social service agencies participate in a one-stop/one-day shopping event such as one done at the Edward King House in Newport**

Building an Age-Friendly Community

Transportation

Challenges and Gaps in Services

The ability to get where one needs or wants to go at a time when one needs to get there is a key factor for successful aging in community, yet transportation is a significant problem among older adults in Rhode Island. RIPTA regular bus routes do not always meet the transit needs of the older population either because seniors may have physical limits preventing them from getting to the bus stop, riding a regular bus, or, in more southern and rural areas, bus service is not available locally. The state's Elderly Mobility Study is outdated (RIPTA, 2010), and a new study should be conducted to identify current transportation services and needs of older adults. Due to funding constraints, the Elderly Transportation Program is limited to certain types of trips and there have been numerous consumer complaints about service provided by LogistiCare, the current broker. Elimination of the no-fare bus program will seriously impact very low-income seniors and the many persons with disabilities using the program. Several successful volunteer programs operate to assist with senior transportation needs but their resources are limited and they cannot always meet demand or expand areas of service.

Senior Voices

- **Transportation was one of the most significant problems identified in all focus groups in all geographic regions of the state**
- **Affordability of transportation was a concern, recognizing the increased fare for public transportation and the cost of the RIDE system (\$4.00/one way)**
- **Many problems identified with the reliability and availability of RIPTA bus and LogistiCare services:**
 - RIPTA buses not picking up at senior housing complexes**
 - RIPTA buses not picking up at convenient locations (long walk for older adults)**
 - LogistiCare drivers arriving late for pick up, resulting in late or missed medical appointments and delays in pick-ups after medical appointments (some spoke of two-hour or more wait)**

- **LogistiCare modes of transportation are not consistent, which causes confusion**
For example, different vehicles/drivers used for pickup and return trips
- **Drivers not always helpful in assisting persons with physical limitations**
- **Rural areas (Richmond, Hopkinton, Exeter and Charlestown) were especially vocal about their need for transportation**

Objectives

- Create a transportation system that is accessible and affordable and meets the needs of older adults

Strategic Actions

1. **Advocate for retention of the free bus fare program or alternate way to provide no-cost rides through vouchers or other means for low-income elders and persons with disabilities**
2. **Conduct a comprehensive senior Transportation/Mobility study including review of options such as “Uber” type service for seniors and use of school buses when not in use**
3. **Conduct a consumer satisfaction survey to assess concerns with LogistiCare’s performance**
4. **Require LogistiCare to create an independent consumer advisory committee to receive consumer input regarding program performance and investigate complaints**
5. **Develop and/or expand volunteer transportation services in parts of the state not adequately served by state/municipal transportation programs**
6. **Create transportation locator website to assist seniors and disabled persons to locate appropriate public and volunteer transportation services**
7. **Expand hours that senior center vans operate so that members can participate in multiple activities (beyond meals)**

Building an Age-Friendly Community

Community and Civic Engagement

Challenges and Gaps in Services

Senior Center participation, volunteering and employment are some of the basic ways that seniors remain connected to and contributing to the community. A large body of evidence exists demonstrating the value of community engagement in promoting health in one's older years and combating loneliness and isolation. Meaningful interpersonal relations are repeatedly cited by older adults as important to health and well-being. Volunteering is associated with better health, fewer functional limitations, lower utilization of health services and lowered mortality risk. Contributory activities can bring a sense of purpose and meaning to life as one grows older.

Senior Centers are highly valued by seniors and provide valuable services tailored to the needs of their local communities. State cutbacks have impacted staffing and the ability of centers to be responsive and provide comprehensive programs. Volunteering among RI seniors is lower than that of seniors in neighboring New England states and needs to be promoted in a planned way.

Senior Voices

- **Participants extremely positive about their senior center experiences: "My Home Away from Home" and "Keeps us Alive"**
- **Senior Center programs not accessible to older adults with no transportation**
- **Loneliness or isolation is a concern for older adults with children/relatives who lived out of state; companionship is needed**
- **Loss of spouse/partner creates a burden for everyday life, which is compounded by grief**
- **Participants fear being alone as their health/function declines and in emergency situations**
- **Loss of independence a major fear; older seniors with increasing health problems worried about their future and ability to remain at home**
- **Problems reported with current home-based services, including lack of access, unreliability of caregivers, inconsistencies in staff and the lack of staff competency**
- **Affordability of home services problematic for older adults who do not qualify for public programs**
- **Participants are currently and/or interested in volunteering at their senior center**
- **Desire to share life experiences and knowledge and to counter "ageism"**
- **Interest expressed in intergenerational opportunities**

Objectives

- To provide a broad-range of opportunities for social and civic engagement for older adults in Rhode Island
- Identify ways to adequately fund senior centers to enable them to expand and offer new programs and services to meet the needs of older adults

Strategic Actions

1. **Restore Senior Center Funding to FY2006 levels**
2. **Create a formula-based funding program for local senior services based on population of older adults**
3. **Encourage senior centers that receive state grants to offer, or to coordinate with the Health Department to offer, health promotion activities**
4. **Identify ways for more persons without transportation to access senior center services**
5. **Promote inter-generational programs at senior centers and in community recreation programs**
6. **Use community-level data to plan programs and senior services**
7. **Support implementation of the “Plan to Increase Volunteering” prepared by Serve RI, the Division of Elderly Affairs and the Senior Agenda Coalition. This plan identifies ways to increase senior volunteerism and engage more non-profit organizations, government leaders and volunteers in a renewed campaign to engage older Rhode Islanders in volunteer service.**
8. **Promote senior center offerings in the communities to increase awareness among older adults.**
9. **Create inter-generational programs with local colleges and universities where students could engage in programs/activities with older adults living in the community, such as yard work, home maintenance, housekeeping, help with medication management, social activity and others.**
11. **Implement daily “check in” program using volunteers (perhaps through cities and towns) to insure the safety of older adults**
12. **Develop programs with schools, youth programs, churches, other community organizations where volunteers could provide services to assist seniors (yard work, house repair, etc.)**
13. **Encourage Assisted Living communities to offer programs/activities for older adults who live in the community to engage them in social/cultural/recreational events**

Building an Age-Friendly Community

Food Security and Nutrition

Challenges and Gaps in Services

Rhode Island offers an extensive statewide program of congregate meals for seniors (the Café Program), but participation has been decreasing slightly. This may partially be a result of lack of transportation to meal sites due to the \$2.00 one-way fee charged by LogistiCare and should be explored. The SNAP program can provide substantial help in paying for food but many seniors may not be aware of the program or hesitate to apply because they think of it as “welfare.”

Senior Voices

- **Feedback on the quality of food served at senior centers was mixed; while some reported enjoying the meals, others were extremely dissatisfied. All valued the socialization of eating meals with others**
- **Dissatisfaction with Meals on Wheels food**
- **The Café model in Cranston was well-liked**
- **Quality of food served at senior housing meal sites not appealing**

Objectives

- To assure that older Rhode Islanders have access to foods that meet their nutritional needs and food preferences

Strategic Actions

1. Analyze strategies for transporting more seniors to the state's meal sites
2. Target SNAP outreach
3. Continue efforts to bring more fresh foods to homebound seniors via mobile food vans and to access food pantries
4. Continue to improve participant satisfaction with food served in nutrition programs
5. Improve the quality and desirability of food served at senior center meal sites
6. Improve the quality of the Meals on Wheels food
7. Increase communication among seniors about food pantries and provide transportation
8. Develop programs with local colleges/universities where students could assist in preparing meals for older adults (i.e. Johnson and Wales culinary program)



Building an Age-Friendly Community

Economic Security

Challenges and Gaps in Services

Rhode Island seniors are not a wealthy group. Twenty-seven percent of older households have income less than \$20,000 and 42% have income less than \$30,000. Income disparities exist based on gender, racial/minority status, age-cohort and geography. Depending on their housing situation, older households need between 200% and 300% of the Federal Poverty Level (FPL) to meet basic living expenses, yet almost one-third have income below twice the poverty level. Seniors may not be aware of the benefits that would help them with living expenses. The Medicaid system has different financial eligibility for different populations and needs to be simplified. Less than half of seniors are estimated to have retirement income (non Social Security) and the state lacks detailed data to project the long term financial vulnerability of its older adults.

Senior Voices

- Grave concerns about ability to finance their own homes and pay for rent as they age
- Some participants interested in Assisted Living but rents may not be affordable
- Would like information on taxes (homestead freeze), legal services, reverse mortgages, financial planning, end-of-life planning (advance directives), etc.

Objectives

- To assure that older Rhode Islanders are economically secure with sufficient income to meet basic expenses relating to housing, food, healthcare and personal needs

Strategic Actions

- 1. Increase resources to the state's senior centers, THE POINT network, and Community Action agencies so that they can provide outreach counseling and enrollment assistance for benefit programs**
- 2. Advocate for the expansion of the Medicare Premium Savings Program to redefine financial eligibility to assist low-income seniors meet healthcare costs**
- 3. Advocate for the standardization of Medicaid eligibility for all Medicaid programs**
- 4. Advocate for the indexing of the SSI benefits to inflation**
- 5. Partner with academic institutions to conduct research on the income security of older adults in Rhode Island**
- 6. Identify ways to better educate Rhode Island seniors in financial planning and retirement savings to help ensure economic security during retirement years**

Building an Age-Friendly Community

Healthcare Access

Challenges and Gaps in Services

Access to affordable quality medical care, including preventive care, rehabilitative care, palliative care, and hospice is important to maintain optimal health in older adults and ensuring death comes with dignity. While 99.4% of seniors have Medicare, older adults incur considerable out-of-pocket costs for deductibles, copayments and items or services not covered by Medicare, including dental care, hearing aids, eyeglasses and most long-term care. Low-income seniors not eligible for Medicaid often face high out-of-pocket costs which may deter them from seeking timely care.

Most seniors report they have a personal health care provider; however, some medical specialties treating chronic conditions suffered by many seniors may be difficult to access due to waiting lists. One out of three primary care practices reported they were not accepting new adult patients. Additionally Rhode Island has a 10% shortage of primary care physicians working in outpatient settings. As in many states, geriatric specialty care is limited and the majority of seniors receive care from primary care providers. The state has a shortage of geriatric behavioral health professionals and many do not accept Medicare. The behavioral health needs of the older population have not been studied by the state and such a study is now underway.

Senior Voices

- **An ageist bias is prevalent among health-care professionals and health-care organizations and seniors described being treated as if they were unintelligent**
- **Older adults are concerned about the cost of health care and some participants shared they forego medication to pay for food or rent, others shared putting off needed care due to costs**

Objectives

- To assure that older adults have access to affordable, accessible, quality health care including behavioral health and oral health care that recognizes their unique needs

Strategic Actions

1. **Promote continuing education for primary care practitioners in geriatric-competent care**
2. **Support development of a state strategic plan for elder behavioral health underway by the Department of Behavioral Health, Developmental Disabilities and Hospitals' work group**
3. **Develop plan to better address oral health needs of low-income older population**
4. **Develop educational programs for healthcare professionals in care that is specific to older adults**

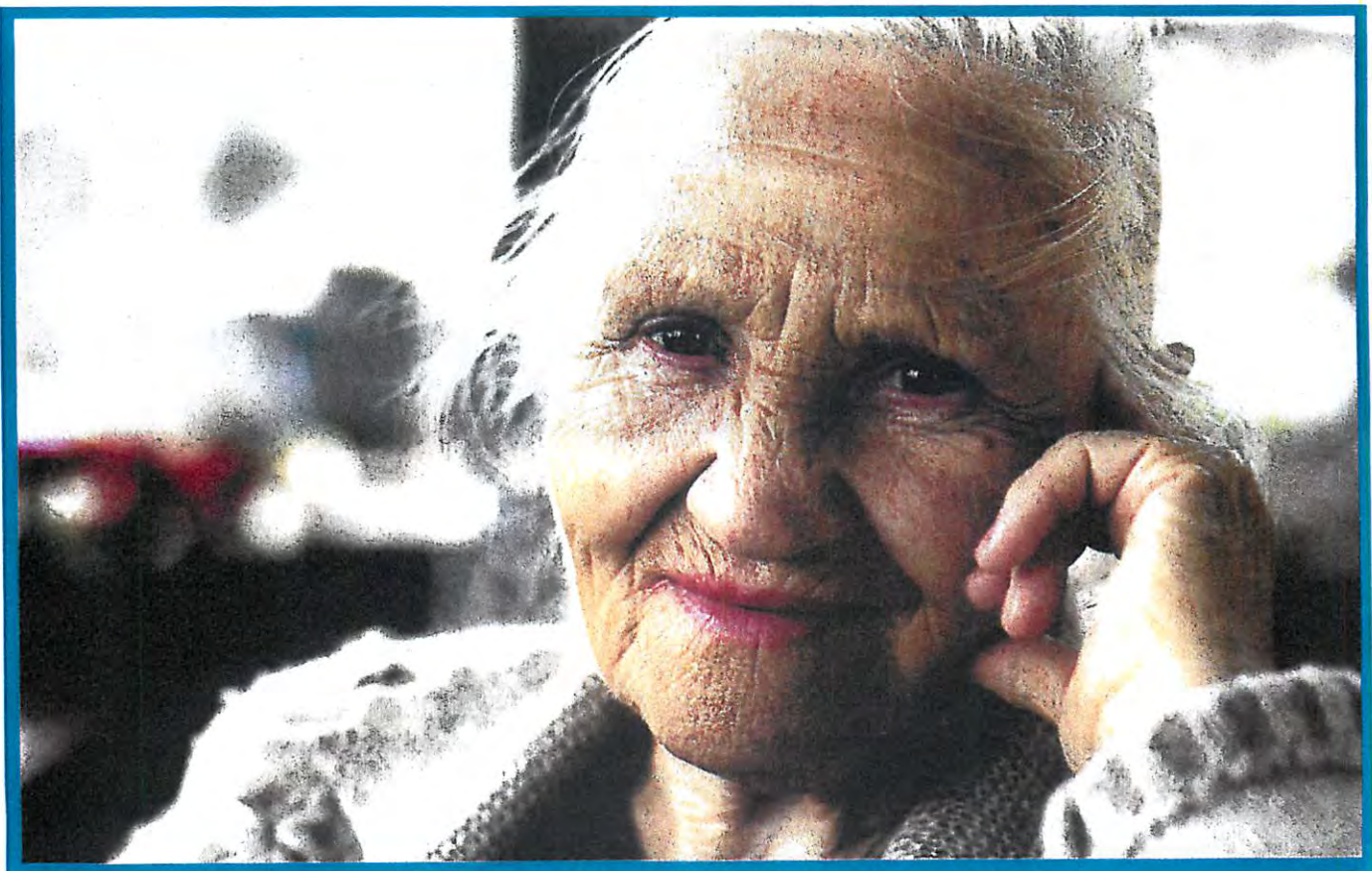

Building an Age-Friendly Community

Outdoor Spaces and Public Buildings

Challenges and Gaps in Services

Outdoor spaces and buildings have a significant impact on mobility and the quality of life of older adults, affecting their independence and choices of where to live. Age-friendly communities feature outdoor spaces and buildings that include safe and accessible streets for pedestrians, the safety and accessibility of public buildings, a clean environment, access to green spaces to sit and walk, and accessible parks and recreational facilities.

Many areas of the state have poor “walkability” features making walking unsafe. While the state has many parks, beaches and open-space areas, non-driving seniors need transportation from family/friends or public transit to enjoy this. Public buildings may lack accessible features. Municipalities vary in their “age-friendliness” relating to open spaces and public areas.

Senior Voices

- Participants had concerns related to mobility in their environments (cracked and crumbling sidewalks)
- Concerns about lack of parks within walking distance where older adults felt safe
- Sidewalks not adequately cleaned after snowstorms in some cities/towns

Objectives

- To create age-friendly communities that feature outdoor spaces and buildings, which include safe and accessible streets for pedestrians, safe and accessible public buildings, a clean environment, access to green spaces for physical exercise and recreation

Strategic Actions

1. **Support implementation of Complete Streets by RI Department of Transportation**
2. **Encourage municipalities to create local age-friendly volunteer committees to assess open spaces and public building features and recommend local action**
3. **Encourage municipal land trusts and conservation commissions to create maps of places appropriate for older adults to walk, exercise and enjoy recreation and leisure**
4. **Assess location of bus stops in relation to the location of senior housing**
5. **Engage cities and towns in repairing sidewalks and promoting safe streets**
6. **Create a map of parks and walking areas to identify space that would be appropriate for older adults walking, exercise, recreation and leisure**

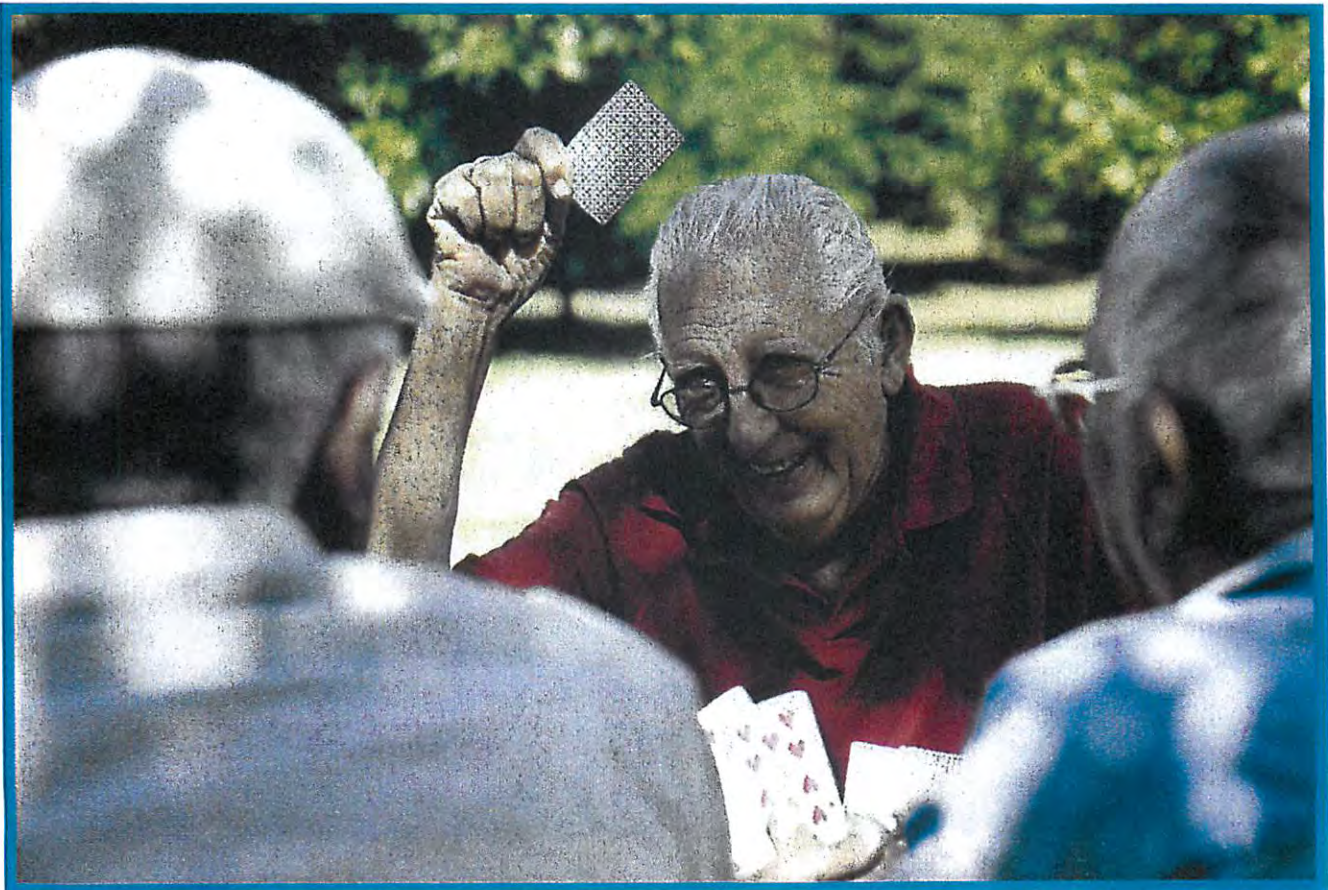

Building an Age-Friendly Community

Housing

Challenges and Gaps in Services

Adequate housing is essential to one's safety and well-being, and there is a strong link between appropriate housing and access to community and support services for the older population. Time and time again the analysis of Rhode Island's housing situation informs policy makers that resources must be redirected to offer both affordable housing and sufficient home and community-based services. The number of senior citizens who rent their homes and are housing cost-burdened has increased dramatically. For seniors in owner-occupied housing on lower fixed incomes, increasing property taxes, and other housing related costs often strain budgets. Due to changing physical needs, seniors in owner-occupied homes may be challenged by structural barriers and home maintenance chores may become problematic. The co-location of older and younger disabled tenants in many of the state's elderly housing facilities can create problems for older tenants. Supportive services provided by resident service coordinators in elderly housing apartments may be lacking or insufficient to help older tenants age in place.

Senior Voices

- **Most older adults desire to remain in their home but struggle to keep up with home maintenance**
- **Lack of services available for older adults in the community, including homemaker services, home maintenance and repair, yardwork/snow removal**
- **24-hour on-site security not provided in senior housing; safety a major concern**
- **Problems among younger residents in senior housing threaten security and safety of older adults**
- **Sanitation problems in some housing complexes included roaches and bed bugs**

Objectives

- A wide range of affordable housing options will be available to meet seniors needs and preferences and allow them to safely age in the community

Strategic Actions

1. **Improve access to affordable housing opportunities through creation of centralized housing locator**
2. **Increase awareness of available municipal property tax credits for seniors, veterans and persons with disabilities and the state Property Tax Relief Circuit Breaker program and advocate to increase the maximum credit amount in the state Property Tax Relief program**
3. **Develop models of community care and supportive housing, including innovative designs that fit the needs of aging adults**
4. **Identify and direct resources to support seniors in senior housing communities, such as training to support the role of resident services coordinators**
5. **Research and promote the development of alternative housing options such as intergenerational, co-housing, accessory dwellings and other models**
6. **Promote “Village” type and neighborhood “hub” community programs**
7. **Create programs and/or identify funds to offer low-interest loans or tax credits for costs of home modifications**
8. **Require 24-hour security/surveillance staff in elderly housing**
9. **Consider policy change to allow subsidized housing just for older adults**

Building an Age-Friendly Community

Supports to Remain at Home

Challenges and Gaps in Services

As persons age they may experience difficulties in carrying out everyday activities due to loss of function. These activities include household tasks (laundry, housekeeping, grocery shopping, food preparation and money management), personal care (bathing, grooming and hygiene) and medication management. Getting assistance with these tasks can mean the difference between remaining in one's home or seeking care in a residential setting (assisted living or nursing home). Home care providers are having severe difficulties in recruiting and maintaining an adequate number of homemaker/home health aides to meet the demand for services. The regional case management agencies serving the Division of Elderly Affairs (DEA) and Neighborhood Health Plan clients report high turnover, increasing bureaucracy and paperwork and duplicate efforts. In many cases, turnaround time for processing Medicaid takes over 60 days, preventing home care services from starting in a timely way which can lead to preventable nursing home placement. Co-Pay clients may need more services than currently allowed to avoid institutionalization. Past cuts to state funds for Elder Respite services have led to wait lists and emergency respite is not always available. Paying for home care services for persons not eligible for government subsidized care is a financial burden for low/middle income families who may resort to nursing home placements paid for by Medicaid. Few Primary Care Providers offer home visits for frail elders to address urgent needs. Financial exploitation of older adults seems to be on the rise and persons suspected of self-neglect may refuse to accept services to promote their health and safety. Finally, hoarding can be a problem and few clinicians are experienced in dealing with the issue.

Senior Voices

- **Loss of independence a major fear; older seniors with increasing health problems worried about their future and ability to remain at home**
- **Problems reported with current home-based service; including lack of access, unreliability of caregivers, inconsistencies in staff and the lack of staff competency**
- **Affordability of home services problematic for older adults who do not qualify for public programs**

Objectives

- Maintain a stable home and community care workforce to meet the needs of seniors requiring assistance to remain at home
- Provide timely and affordable access to a range of home/community services based on client needs, goals and preferences
- Provide support services for unpaid “family” caregivers

Strategic Actions

- 1. Increase home care provider rates in state supported programs**
- 2. Expand Co-Pay program hours for home care and days of adult day service**
- 3. Expedite eligibility for home and community-based services**
- 4. Explore ways to offer affordable homemaker and home repair/maintenance services**
- 5. Promote in-home medical visits for frail elders with complex needs**
- 6. Promote telehealth technology**
- 7. Increase funding for Elder Respite**
- 8. Develop and offer hands-on caregiver training programs including for those caring for persons with behavioral health issues and dementia**
- 9. Expand Temporary Caregiver Insurance law from four to six weeks**
- 10. Promote telephone reassurance services**
- 11. Create partnerships with schools, colleges, churches and community service groups so adolescents and young adults could provide services to seniors living in the community**

Aging in Community



Executive Summary Report June 2016

The following persons are gratefully acknowledged for participating in the Subcommittee's work

Christine Amedeo Heather Amaral Linda A'Vant-Deishinni
Kirsten Bryan Deb Burton Susan Bouchard
Bernie Boudreau Councilwoman Barbara Capalbo Marie Carpenter
Senator Carol Cool Rumsey John Dooley Rachel Filinson Bill Flynn
Jim Dealy John DiTamasso Joyce Dolbec Craig Dwyer Cathy Gorman
Linda Katz Kathleen Langford Skye Leedahl Erin McAndrew
Kathy McKeon Paula McFarland Karen Mensel Maureen Maigret
Connie Milbourne Mary Lou Moran Jessica Mowry Manny Murray
Paula Parker Susan Pomfret Esther Price Susan Saccoccio-Olson
Janet Spinelli Marianne Raimondo Corinne Russo
Karen Ryan Karen Testa Kali Thomas
Meg Underwood Mike Walker

Daniel J. McKee, *Lieutenant Governor*
Chair, Long Term Care Coordinating Council

Funding to support the focus groups was partially provided by the Rhode Island Division of Elderly Affairs, with funds from the Older Americans Act, to assist in the development of Rhode Island's State Plan on Aging and in part by a grant from the Tufts Health Plan Foundation.

The full subcommittee report is available at: <http://www.ltgov.ri.gov/>

AGING IN COMMUNITY SUBCOMMITTEE REPORT

EXECUTIVE SUMMARY

Recognizing the projected growth in Rhode Island's older population in 2014 the General Assembly passed the Aging in Community Act of 2014 (RIGL 42-66.11). The law called for creation of an Aging in Community Subcommittee of the Long Term Care Coordinating Council with the following purpose:

“To develop a plan to provide the needed infrastructure and program improvements in support services, housing and transportation that will enable the state's growing elder population to safely remain living at home and in community settings. The aging in community plan shall include an inventory of available services, identification of service and program gaps and resource needs. In addition to members of the long-term care coordinating council, the subcommittee shall include those members of the state's academic community with expertise in aging services and community-based long-term supports and services as the council deems appropriate.”

Organized in October 2014 the Subcommittee has worked to gather information about issues in nine areas important for successful “Aging in Community.” It heard about aging-related services provided by the state government and community agencies, reached out to seniors to hear about issues of concern to them through ten focus groups conducted across the state. It held interviews with key aging service providers and looked at best practices to promote age-friendly communities in a number of states.

Growth of Rhode Island Older Population

The Rhode Island Statewide Planning Office projects that by 2030 the percent of persons age 65 and over will increase from 15.8% in 2014 to 23.1%. In sheer numbers this will mean almost 100,000 more persons in Rhode Island aged 65 and over. By 2040, there will be a 100% increase in persons ages 74 to 84 and a 72% increase in persons age 85 and over. These latter age cohorts are more likely to need support services to help them to remain living in the community.

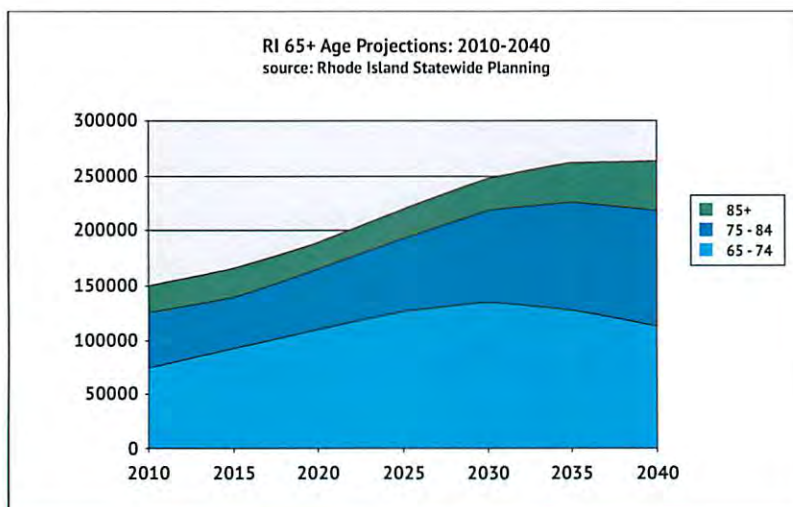

The growth in the state’s “old” (ages 75-84) and “old-old” (ages 85 and over) is of particular importance in recommending strategies for Aging in Community. Survey data from the Rhode Island Department of Health found the majority of older Rhode Islanders have two or more chronic diseases, and 50% of those over age 85 have some sort of physical limitation. The table below details the percentages reporting poor or fair health, at least one day of poor physical health in the past month, at least one day of poor mental health in the past month, and prevalence of disability. It distinguishes between the young-old, old, and oldest-old subgroups of the senior population. The table demonstrates the 50% or greater rise in unsatisfactory health ratings and disability between ages 65 to 85.

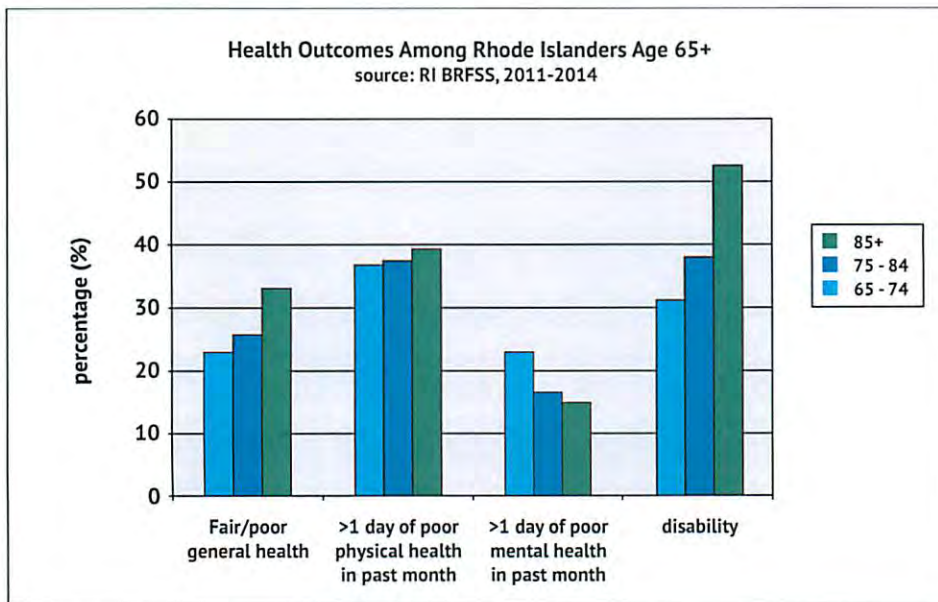

Economic Value and Contributions of the Rhode Island Older Population

Helping seniors to remain active and engaged is smart public policy as older Rhode Islanders contribute substantially to the state’s economy through Social Security payments, labor force participation, volunteering and serving as family caregivers.

- Social Security economic value to Rhode Island
 - » Total 2012 Social Security benefits: \$2.9 billion
 - » Provides \$4.98 billion in economic output
 - » Generated \$281 million in state and federal taxes
 - » 33,750 jobs across all sectors
- Older Rhode Islanders as caregivers
 - » An estimated 134,000 Rhode Islanders are unpaid caregivers
 - » Total estimated value of \$1.78 billion

- Older Rhode Islanders as volunteers
 - » 65,000 volunteers age 55 and older in Rhode Island
 - » \$149 million of service contributed

THE VOICES OF SENIORS

Ten focus groups with older adults were conducted across the state of Rhode Island to assess their needs as they age and to identify gaps in services. A summary of their input and identified problems follows.

Communication and Information

- Need for and difficulty in finding information about available services
 - » Participants were not aware of “THE POINT” or the services available
 - » Difficulty with the responsiveness of the Department of Human Services (phone calls not answered or returned, inaccurate information provided and a lack of customer service)
- Information Specialist at the senior centers helpful but not always available
- Children and caregivers need information about finances and end-of-life planning
- Information available online not always a preferable channel of communication

“It’s unclear what is available for different income groups.”

“I worry what will happen when I can’t drive.”

Transportation

- Transportation was one of the most significant problems identified in all focus groups in all geographic regions of the state
- Affordability of transportation was a concern, recognizing the increased fare for public transportation and the cost of the RIDE system (\$4.00/one way)
- Many problems identified with the reliability and availability of LogistiCare:
 - » Buses/vans not always picking up at senior housing complexes
 - » Buses/vans arriving late for pick up, resulting in late or missed medical appointments and delays in pick-ups after medical appointments (some spoke of two-hour or more wait)
 - » Buses/vans not picking up at convenient locations (long walk for older adults)
 - » Modes of transportation are not consistent, which causes confusion. For example, different vehicles/drivers used for pickup and return trips
 - » Drivers not always helpful in assisting persons with physical limitations
 - » Rural areas (Richmond, Hopkinton, Exeter, and Charlestown) were especially vocal about their need for transportation

Economic Security

- Affordability of remaining in one's home was a major concern (mortgage/rent, taxes, home maintenance and repair are all a financial burden)
- Assisted living is desirable but the cost is prohibitive
- Information needed on legal services, reverse mortgages and financial planning
- Taxes are a burden for older adults, many would be helped by a homestead freeze and no tax on social security

“It’s all about surviving.”

Community and Social Support

- Participants extremely positive about their senior center experiences: “My Home Away from Home” and “Keeps us Alive”
- Senior center programs not accessible to older adults with no transportation
- Loneliness or isolation a concern for older adults with children/relatives who lived out of state; companionship is needed
- Loss of spouse/partner creates a burden for everyday life, which is compounded by grief
- Participants fear being alone as their health/function declines and in emergency situations
- Loss of independence a major fear; older seniors with increasing health problems worried about their future and ability to remain at home
- Problems reported with current home-based services, including lack of access, unreliability of caregivers, inconsistencies in staff and the lack of staff competency
- Affordability of home services problematic for older adults who do not qualify for public programs

“The socialization keeps us alive.”

Volunteerism

- Participants are currently and/or interested in volunteering
- Desire to share life experiences and knowledge and to counter “ageism”
- Interest expressed in intergenerational opportunities

Nutrition Assistance/ Food Security

- Feedback on the quality of food served at senior centers was mixed; while some reported enjoying the meals, others were extremely dissatisfied. All valued the socialization of eating meals with others

- Dissatisfaction with Meals on Wheels food
- The Café model in Cranston was well-liked
- Quality of food served at senior housing meal sites not appealing

Housing

- Most older adults desire to remain in their home but struggle to keep up with home maintenance
- Lack of services available for older adults in the community, including homemaker services, home maintenance and repair, yard work/snow removal
- 24-hour on-site security not provided in senior housing; safety a major concern
- Problems with theft, rowdy and noisy parties, and alcohol/drug use among younger residents in senior housing
- Sanitation problems in some housing complexes included roaches and bed bugs

“I am treated like I am less than visible.”

Healthcare

- An age bias is prevalent among healthcare professionals and healthcare organizations and seniors described being treated as if they were unintelligent
- Concerns about the cost of healthcare with some participants sharing they forego medication to pay for food or rent; others shared putting off needed care due to costs

Open Spaces, Public Access to Buildings

- Participants had concerns related to mobility in their environments (cracked and crumbling sidewalks)
- Concerns about lack of parks within walking distance where older adults felt safe
- Sidewalks not adequately cleaned after snowstorms in some cities/towns

KEY FINDINGS AND RECOMMENDED STRATEGIES

The Subcommittee selected nine different issue areas or domains important for Aging in Community for review. Recommended strategies to promote Aging in Community in Rhode Island are based on the service and resource information gathered, the input of seniors gathered from the ten focus groups, survey work, and key informant interviews with providers and advocates, and research on best practices.

Rhode Island provides an array of services and supports that assist its older population

to “Age in Community.” However, in many areas resource constraints limit the ability to provide adequate services to meet demand.

Communication and Information – Rhode Island has not achieved the goal of meeting a “*No Wrong Door-One Stop*” approach to providing timely and accurate information to its seniors about services and benefits available them. Dedicated federal funding to support THE POINT, the state’s Aging and Disability Resource Center (ADRC) and, the state’s primary source of information for seniors, has ended and no state funding currently supports its activities. The state lacks a functional website for THE POINT network. The existing web address says THE POINT site is “under construction,” and it has been this way for a number of years. For those middle-income seniors not eligible for most public benefits/program, Options Counseling is not always available and counselors may not be adequately trained to offer middle-class consumers and families’ information and advice about options for keeping seniors at home.

Transportation – The 2010 Rhode Island Human Services Transportation Report is outdated and the state needs to conduct an Older Adult Mobility Study. RIPTA regular bus routes do not always meet the transit needs of the older population either because seniors may have physical limits preventing them from getting to the bus stop, riding a regular bus, or, in more southern and rural areas, bus service is not available locally. Due to funding constraints, the Elderly Transportation Program is limited to certain types of trips, and there have been numerous consumer complaints about service provided by LogistiCare, the current broker. The proposed elimination of the no-fare bus program will seriously impact very low-income seniors and the many persons with disabilities using the program. Several successful volunteer programs operate to assist with senior transportation needs but their resources are limited and they can not always meet demand or expand areas of service.

Economic Security – Rhode Island seniors are not a wealthy group. Twenty-seven percent of older households have income less than \$20,000 and 42% have income less than \$30,000. Income disparities exist based on gender, racial/minority status, age-cohort and geography. Depending on their housing situation, older households need between 200% and 300% of the Federal Poverty Level (FPL) to meet basic living expenses, yet almost one-third have income below twice the poverty level. Seniors may not be aware of the benefits that would help them with living expenses. The Medicaid system has different financial eligibility for different populations and needs to be simplified. Less than half of seniors are estimated to have retirement income (non Social Security) and the state lacks detailed data to project the long term financial vulnerability of its older adults.

Community and Social Engagement – Senior centers are highly valued by older adults and provide valuable services tailored to the needs of their local communities. State cutbacks have impacted staffing and the ability of centers to be responsive and provide comprehensive programs. Volunteering among Rhode Island seniors is lower than that of seniors in neighboring New England states and needs to be promoted in a planned way.

Food Security and Nutrition Assistance – The state offers an extensive statewide program of congregate meals for seniors (the Café Program), but participation has been decreasing slightly. This may be partially a result of lack of transportation to meal sites due to the \$2.00 one-way fee charged by LogistiCare and should be explored. The Supplemental Nutrition Assistance Program (SNAP) can provide substantial help in paying for food, but many seniors may not be aware of the program or hesitate to apply because they think of it as “welfare.”

Housing – The number of senior citizens who rent are burdened by the rising cost of housing which has increased dramatically. For seniors in owner-occupied housing on lower fixed incomes, increasing property taxes, and other housing related costs often strain budgets. Due to changing physical needs, seniors in owner-occupied homes may be challenged by structural barriers and home maintenance chores may become problematic. The co-location of older and younger disabled tenants in many of the state’s elderly housing facilities can create problems for older tenants. Supportive services provided by resident service coordinators in elderly housing apartments may be lacking or insufficient to help older tenants age in place.

Supports to Remain At Home – Home care providers are having severe difficulties in recruiting and maintaining an adequate number of homemaker/home health aides to meet demand. The regional case management agencies serving the Division of Elderly Affairs (DEA) and Neighborhood Health Plan clients report high turnover, increasing bureaucracy and paperwork and duplicate efforts. In many cases, turnaround time for processing Medicaid takes over 60 days, preventing home care services from starting in a timely way which can lead to preventable nursing home placement. Co-Pay clients may need more services than currently allowed to avoid institutionalization. Past cuts to state funds for Elder Respite services have led to wait lists and emergency respite is not always available.

Healthcare Coverage and Access – Low-income seniors not eligible for Medicaid often face high out-of-pocket costs which may deter them from seeking timely care. Most seniors report they have a personal healthcare provider; however, some medical specialties treating chronic conditions suffered by many seniors may be difficult to access due to waiting lists. One out of three primary care practices reported they were not accepting new adult patients. As in many states, geriatric specialty care is limited, and the majority of seniors receive care from primary care providers. The state has a shortage of geriatric behavioral health professionals and many do not accept Medicare. The behavioral health needs of the older population have not been studied by the state and such a study is now underway. Dental care is not covered by Medicare and finding affordable dental care may be problematic for seniors.

Open Spaces and Public Buildings – Many areas of the state have poor “walkability” features making walking unsafe. Non-driving seniors need transportation from family/friends and/or public transit to enjoy the state’s many parks and recreation areas. Municipalities vary in their “age-friendliness” relating to open spaces and public areas.

RECOMMENDED STRATEGIES TO PROMOTE AGING IN COMMUNITY

COMMUNICATION AND INFORMATION

1. Create an interactive web site for THE POINT
2. Enact a specific ADRC enabling statute with a state appropriation
3. Co-locate staff from the Department of Human Services long term care eligibility offices in THE POINT programs
4. Provide Options Counseling staff with permissions to access to Medicaid client information (with client approval)

TRANSPORTATION

1. Retain free bus fare program or alternate way to provide no-cost rides through vouchers or other means for low-income elders and persons with disabilities
2. Conduct a comprehensive senior transportation/mobility study including review of options such as Uber for seniors and use of school buses when not in use
3. Seek consumer input and satisfaction data on LogistiCare performance
4. Promote volunteer transportation services
5. Create transportation locator website

ECONOMIC SECURITY

1. Improve benefits counseling
2. Expand Medicare Premium Savings Program
3. Standardize Medicaid eligibility
4. Index the state Supplemental Security Income (SSI) benefits
5. Support new research on Rhode Island Elder Income Security
6. Promote financial planning and services programs for seniors
7. Promote retirement savings accounts

COMMUNITY AND SOCIAL ENGAGEMENT

1. Restore senior center funding to FY2006 levels
2. Create formula-based funding program for local senior services based on population of older persons in a community
3. Encourage senior centers that receive state grants to offer, or to coordinate with, the Health Department to offer, health promotion activities
4. Identify ways for more persons without transportation to access senior center services
5. Promote inter-generational programming at senior centers and in community recreation programs

6. Use community-level data to plan programs and senior services
7. Support SERVE RI Volunteer Plan

FOOD SECURITY AND NUTRITION

1. Analyze strategies for transporting more seniors to the state's meal sites
2. Target SNAP outreach to areas with greatest number of low-income seniors
3. Continue efforts to bring more fresh foods to homebound seniors via mobile food vans and to access food pantries
4. Continue to improve participant satisfaction with food served in nutrition programs

HOUSING

1. Improve access to affordable housing opportunities through centralized housing locator
2. Increase awareness of available municipal property tax credits for seniors, veterans and persons with disabilities and the state Property Tax Relief Circuit Breaker program
3. Develop innovative models of community care and supportive housing including universal design that fit the needs of aging adults
4. Provide funding and training to support the role of resident services coordinators
5. Encourage development of alternative housing options such as co-housing and accessory dwellings
6. Promote "Village" type community programs
7. Create or identify funds to offer low-interest loans or tax credits for costs of home modifications
8. Require 24-hour security/surveillance staff in elderly housing
9. Consider policy change to allow subsidized housing just for older adults

SUPPORTS TO STAY AT HOME

1. Increase home care provider rates in state supported programs
2. Expand Co-Pay program hours for home care and days of adult day service
3. Expedite eligibility for home and community-based services
4. Explore ways to offer affordable homemaker and home repair/maintenance services
5. Promote in-home medical visits for frail elders with complex needs
6. Promote telehealth technology
7. Increase funding for Elder Respite

8. Develop and offer hands-on caregiver training programs including for those caring for persons with behavioral health issues
9. Expand Temporary Caregiver Insurance law from four to six weeks
10. Promote telephone reassurance services

HEALTHCARE ACCESS

1. Promote continuing education for primary care practitioners in geriatric-competent care
2. Support development of a state strategic plan for Elder Behavioral Health underway by the Department of Behavioral Health, Developmental Disabilities and Hospitals' work group
3. Develop plan to better address oral health needs of low-income older population

OPEN/PUBLIC SPACES AND PUBLIC BUILDINGS

1. Continue implementation of Complete Streets by Rhode Island Department of Transportation
2. Encourage municipalities to create local Age-friendly volunteer committees
3. Encourage municipal Land Trusts and Conservation Commissions to create maps of places appropriate for older adults to walk, exercise and enjoy recreation and leisure

NEXT STEPS

The next phase of this work will be to form a coalition to build an Age-Friendly Rhode Island, to make the state a better place to live for people of all ages, and to also recognize the special needs of the state's growing older population. It will involve a multi-year effort requiring a robust coalition committed to a common vision to include representatives of all sectors including government leaders, the business community, community organizations and consumers. With support from a Tufts Health Plan Foundation grant, the following next steps will be pursued:

- Developing a strategic implementation plan with goals and objectives to achieve the Subcommittee's recommended strategies
- Engaging leaders from all sectors to join the coalition and become "Age-Friendly" champions
- Promoting local "Age-Friendly" initiatives responsive to resident input and community data

The Subcommittee welcomes and encourages readers of this report to join the coalition and to work to make Rhode Island and its communities "Age-Friendly."

Rhode Island Healthy Aging Data Report

120 health risk indicators in 39 communities*

KEY FINDINGS



Rhode Island has the **highest proportion in U.S. of adults age 85 and older.**



RI has **highest rates in New England states** for older adults having ever been diagnosed with

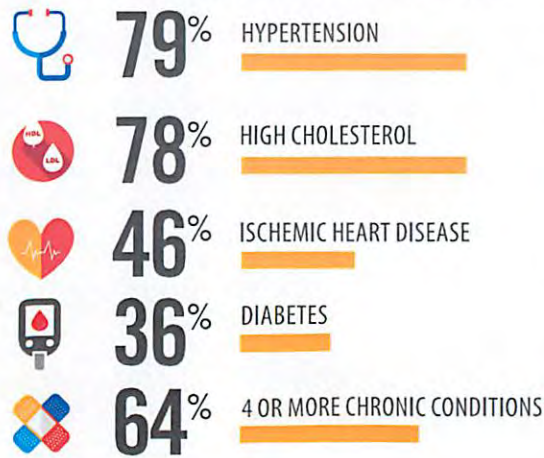

HEALTH DISPARITIES

When it comes to healthy aging, resources matter. The map below shows the variability of healthy aging throughout the state.

HIGHEST RATE (9.1% to 13%) of Medicare beneficiaries who also receive Medicaid long-term services **AND MORE WORSE-THAN-AVERAGE** indicators

HIGHEST RATE (9.1% to 13%) of Medicare beneficiaries who also receive Medicaid long-term services

HIGH RATE (6% to 9%) of Medicare beneficiaries who also receive Medicaid long-term services **AND MORE WORSE-THAN-AVERAGE** indicators

HIGH RATE (6% to 9%) of Medicare beneficiaries who also receive Medicaid long-term services

MORE BETTER-THAN-AVERAGE indicators



RECOMMENDATIONS



UNDERSTAND AND ENGAGE.

Download your Community Profile. Explore the Highlights Report. Bring people together to discuss what the data mean and what can be done to address opportunities and challenges in your community.



PLAN AND ACT.

Use data to prioritize needs and identify interventions. Start with winnable battles. Develop relevant statewide plans.

Identify what's working in communities that are healthier than state average. Can this be replicated in communities facing challenges in healthy aging?

Prioritize efforts that address below-average indicators for North Providence, Johnston, Central Falls, Pawtucket, Providence.

Collaborate with local leaders and communities to identify ways to become more age-friendly.

Promote opportunities for community and civic engagement for older adults.

* Data reflect health for adults age 60+ or 65+ in Rhode Island

Learn more at healthyagingdatareports.org/rhode-island

HEALTHY AGING INDICATORS	COMMUNITY ESTIMATE ²	STATE ESTIMATE ²	
ECONOMIC AND FINANCIAL			
Poverty (65+ Population)			
% with income below the poverty level past year	1.2%	8.6%	
% 60+ receiving food stamps past year	6.1%	11.9%	
% 65+ working past year	29.4%	16.3%	
Household income (65+ householder)			
% households with annual income < \$20,000	11.8%	28.0%	
% households with annual income \$20,000-49,999	9.1%	34.2%	
% households with annual income ≥ \$50,000	79.2%	37.7%	
% 60+ own home	55.0%	43.9%	
% 60+ homeowners with mortgage	36.3%	45.3%	
COST OF LIVING	\$ COUNTY ESTIMATE	\$ STATE ESTIMATE	RATIO OF COUNTY TO STATE
Elder Economic Security Standard Index			
Single, homeowner without mortgage, good health	\$23,256	\$22,188	1.05
Single, renter, good health	\$24,996	\$23,544	1.06
Couple, homeowner without mortgage, good health	\$33,420	\$32,352	1.03
Couple, renter, good health	\$35,160	\$33,708	1.04

TECHNICAL NOTES: Read our technical report for information on data sources and methodology at <http://healthyagingdatareports.org/ri/technicalreport>.

¹ For most indicators the community and state values are both statistical estimates derived from sample data. Thus, it is possible that some of the differences between state and community estimates may be due to chance associated with population sampling. We use the terms "better" and "worse" to highlight differences between community and state estimates that we are confident are not due to chance. When an upper case letter is used the 95% confidence intervals were used, the lowercase indicates a 90% confidence interval. When the implication for healthy aging is unclear we use an *.

² "C" indicates that the community rate is censored due to inadequate sample size and "NA" indicates that the data were not available.

Other notes:

- We used a hierarchical approach to reporting estimates for every city/town in Rhode Island when data allow. In other cases, we could only report indicators for aggregated areas (e.g., cities and towns with similar demographic and socioeconomic population composition were combined for some indicators and counties were used for others). The same estimate is reported for all cities/towns within aggregated geographic areas.
- Total population estimates are from the 2010 Census and are reported for the 41 geographic units. Other population characteristic estimates are from the American Community Survey (ACS) (2009-2013) and are reported for 41 geographic units. Note that % may not add up to 100% due to rounding error.
- Mortality rate, specific chronic disease, access and utilization estimates are for beneficiaries 65 years or older in 2013 from the 2012 and 2013 Centers for Medicare and Medicaid Services (CMS) Master Beneficiary Summary File (MBSF).
- The 2009-2014 Behavioral Risk Factor Surveillance System (BRFSS) is the source for wellness, health behavior, and some prevention estimates. BRFSS indicators were estimated for persons 60 years or older for 14 aggregated geographic areas derived by combining cities and towns with similar population composition. The same rate is reported for all cities/towns within the same unit.
- Access to care data pertaining to the # of primary care providers, hospitals, nursing homes, and home health agencies were obtained from the following CMS websites: <http://www.medicare.gov/nursinghomecompare/search.html>, <http://www.medicare.gov/homehealthcompare/search.html>, <http://www.medicare.gov/hospitalcompare/search.html>, <http://www.medicare.gov/physiciancompare/results.html>. The dentist data come from the RI Department of Health (<http://www.health.ri.gov/find/oralhealthservices/>).
- Walkability Estimates were downloaded from <http://www.walkscore.com/> using the finder term "city/town name, Rhode Island."
- Air pollution/air quality estimates are from the US Environmental Protection Agency reported for 3 RI counties for older adults with no specific health concerns (2015). The same rate is reported for cities/towns within the same county.
- 2012 voter participation data from the Rhode Island Board of Elections.
- Crime estimates are from 2013 FBI Uniform Crime Reports (<http://www.fbi.gov/stats-services/crimestats>).
- Data on fatal auto (driver, passenger) and pedestrian accidents for persons age 60+ is from the Fatal Accident Reporting System of the National Highway Traffic Safety Administration (2009-2013), reported at the town and county level.
- The housing, migration, and income indicators are from the ACS (2009-2013) and are reported for individual cities/towns.
- The 2016 Elder Economic Security Standard Index estimates were obtained from researchers at the University of Massachusetts Boston Center for Social and Demographic Research on Aging.
- Our research team: Elizabeth Dugan, Frank Porell and Nina Silverstein. Graduate Student researchers included: Chae Man Lee, Hyo Jung Lee, Bon Kim, and Krystal Kittle. We thank Amanda Cox from the [NYTimes.com](http://www.nytimes.com) for data visualizations; and Maureen Maigret for sharing data on municipal senior transportation and volunteer driver programs collected by Mensel & Maigret (April, 2016). Please send your questions, comments, or ideas to beth.dugan@umb.edu. Let us know how you are using the Data Report in your community!

HEALTHY AGING INDICATORS	BETTER / WORSE STATE RATE¹	COMMUNITY ESTIMATE²	STATE ESTIMATE²
SERVICE UTILIZATION			
Physician visits per year	*	7.2	8.0
Emergency room visits/1000 persons 65+ years per year	*	403	628
Part D monthly prescription fills per person per year	*	39.9	54.2
Home health visits per year	*	2.3	3.7
Durable medical equipment claims per year	*	0.8	2.0
Inpatient hospital stays/1000 persons 65+ years per year	*	168	284
Inpatient hospital readmissions (as % of admissions)		14.4%	16.9%
Skilled nursing facility stays/1000 persons 65+ years per year	*	60	100
Total skilled nursing home Medicare beds/1000 persons 65+ years		0	52
% 65+ getting Medicaid long term services and supports		1.9%	6.2%
COMMUNITY VARIABLES & CIVIC ENGAGEMENT			
Air Pollution/Air Quality Index			
Annual # of unhealthy days for older adults		NA	NA
Walkability of Community			
Walkability score (0-100)		52	NA
% of vacant housing units in community		23.9%	11.3%
% 60+ who are satisfied with neighborhood	B	87.0%	80.0%
# of registered voters (age 18+)		4,793	725,309
Voter participation rate in 2012 presidential election (age 18+)		75.2%	61.5%
% 60+ who believe local service orgs understand needs	B	54.1%	44.1%
% 60+ who believe he/she can make a difference	B	61.1%	51.6%
% 60+ who believe working together can make a difference		84.4%	81.0%
% 60+ who volunteer at least once per month	b	27.8%	22.8%
% 60+ who attend community events (e.g., church, club) at least once per month	B	54.2%	44.2%
SAFETY AND TRANSPORTATION			
Violent crime rate / 100,000 persons		18	253
Property crime rate / 100,000 persons		1,011	2,394
# of motor vehicle fatalities involving adult age 60+/town		0	90
# of motor vehicle fatalities involving adult age 60+/county		14	90
# of alternative transportation programs by county		7	43
Municipal senior transportation available		Yes	NA
Volunteer driver programs available		RSVP	NA

HEALTHY AGING INDICATORS	BETTER / WORSE STATE RATE¹	COMMUNITY ESTIMATE²	STATE ESTIMATE²
% with hypertension	B	63.4%	79.0%
% ever had a heart attack	B	3.6%	5.4%
% with ischemic heart disease	B	32.6%	45.9%
% with congestive heart failure	B	15.5%	24.8%
% with atrial fibrillation	B	12.6%	15.2%
% with osteoarthritis/rheumatoid arthritis	B	44.0%	52.0%
% with osteoporosis	B	13.2%	21.0%
% with glaucoma		26.7%	26.6%
% with cataract		69.6%	67.9%
% women with breast cancer		13.9%	10.7%
% with colon cancer		2.1%	3.2%
% men with prostate cancer		11.8%	13.8%
% with lung cancer		1.3%	2.1%
% with hypothyroidism	B	14.3%	21.1%
% with anemia	B	37.0%	52.2%
% with benign prostatic hyperplasia	B	31.8%	40.3%
% with chronic kidney disease	B	17.3%	23.3%
Summary chronic disease measures			
% with 4+ chronic conditions	B	45.1%	63.9%
% with 0 chronic conditions	B	13.0%	8.4%
LIVING WITH DISABILITY			
% 65+ with hearing difficulty		10.5%	13.8%
% 65+ with vision difficulty		1.9%	5.2%
% 65+ with cognition difficulty		7.0%	7.8%
% 65+ with ambulatory difficulty		7.4%	19.9%
% 65+ with self-care difficulty		5.1%	6.6%
% 65+ with independent living difficulty		5.1%	13.7%
ACCESS TO CARE			
Medicare (65+ population)			
% Medicare managed care enrollees	*	27.4%	39.4%
% dually eligible for Medicare and Medicaid	*	3.6%	14.6%
% with a regular doctor	B	98.2%	96.5%
% did not see a doctor when needed due to cost	b	4.1%	6.3%
# of primary care providers (within 5 miles)		51	1,566
# of hospitals (within 5 miles)		1	11
# of nursing homes (within 5 miles)		0	84
# of home health agencies (in same town)		13	38

HEALTHY AGING INDICATORS	BETTER / WORSE STATE RATE¹	COMMUNITY ESTIMATE²	STATE ESTIMATE²
Geographic Migration (65+ population)			
% moved within same county		0.0%	3.5%
% moved from different county in Rhode Island		0.0%	0.8%
% moved from different state		3.1%	1.1%
% 60+ lived at same address 25 years or more		49.2%	48.1%
WELLNESS and PREVENTION			
% any physical activity within last month	B	78.7%	70.0%
% injured by a fall within last year		10.0%	10.0%
% ever had a hip fracture	B	2.6%	3.9%
% with self-reported fair or poor health status	b	16.3%	20.4%
% with 15+ physically unhealthy days last month		11.7%	13.9%
% with physical exam/check-up in past year		91.7%	91.9%
% met CDC preventive health screening goals		41.1%	39.5%
% flu shot past year		60.2%	59.1%
% pneumonia vaccine		74.9%	73.8%
% shingles vaccine		35.5%	30.3%
% cholesterol screening		87.2%	88.4%
% mammogram within last 2 years (women)		77.9%	81.8%
% colorectal cancer screening		78.9%	76.1%
Oral Health			
% with complete tooth loss	B	23.9%	32.4%
% with annual dental exam	B	84.7%	74.7%
# dentists per 100,000 persons (all ages)		37	58
NUTRITION/DIET			
% with 5 or more servings of fruit or vegetables per day		23.9%	23.0%
% obese		22.1%	25.4%
% high cholesterol	B	66.7%	78.0%
% current smokers		7.3%	8.9%
% excessive drinking	W	13.9%	8.9%
MENTAL HEALTH			
% with 15+ days poor mental health last month	B	4.8%	7.5%
% 60+ talked with family or friends almost daily	b	79.9%	75.3%
% ever diagnosed with depression	B	20.8%	30.0%
CHRONIC DISEASE			
% with Alzheimer's disease or related dementias	B	9.0%	14.4%
% with diabetes	B	19.8%	35.7%
% with stroke	B	8.8%	12.5%
% with chronic obstructive pulmonary disease	B	15.7%	24.1%
% with asthma	B	9.8%	14.0%

Jamestown (Newport)

Jamestown is a town located in Newport County with a population of 5,405. About 18% of Jamestown residents are age 65 or older. With the exception of a higher than state rate of excessive drinking, Jamestown older adults fare better than or the same as state estimates on most other health indicators. Child and Family Services part of the state Aging and Disability Resource Center, the POINT Network, provides information, referral and assessment services and case management for seniors receiving state-funded home and community services. Age-friendly community resources include the senior center that offers weekday full-service luncheons, yoga tools for wellness, crazy quilting, knitting, Tai Chi, and line dancing. The Jamestown recreation department facilitates indoor and outdoor walking clubs. The Jamestown Philomenian Library offers special programs such as technology demonstrations and matinee movies. The Town provides some transportation for shopping and appointments.



POPULATION CHARACTERISTICS	COMMUNITY ESTIMATE	STATE ESTIMATE
Total population all ages	5,405	1,052,567
Population 60 years or older as % of total population	25.6%	20.6%
Total population 60 years or older	1,387	217,066
Population 65 years or older as % of total population	18.1%	14.8%
Total population 65 years or older	981	155,558
% 65-74 years	65.5%	50.4%
% 75-84 years	25.1%	32.0%
% 85 years or older	9.4%	17.6%
Gender (65+ population)		
% female	53.1%	58.4%
Race/Ethnicity (65+ population)		
% White	92.0%	93.0%
% African American	2.3%	2.6%
% Asian	0.0%	1.3%
% Other	5.6%	3.2%
% Hispanic/Latino	1.9%	3.7%
Marital Status (65+ population)		
% married	70.3%	50.1%
% divorced/separated	7.5%	12.6%
% widowed	22.1%	30.8%
% never married	0.0%	6.4%
Education (65+ population)		
% with less than high school education	0.0%	26.8%
% with high school or some college	55.0%	50.7%
% with college degree	45.0%	22.5%
% of 60+ LGBT	1.2%	2.0%
% of 65+ population living alone	17.8%	30.4%
% of 65+ population who speak only English at home	100.0%	81.7%
% of 65+ population who are veterans of military service	30.7%	22.7%
Age-sex adjusted 1-year mortality rate	4.2%	4.8%



NEWPORT BRIDGE - 216KW AC

1 EAST SHORE ROAD

JAMESTOWN, RI

PROJECT DATA - 216 KW AC

OWNER: RITBA RI SOLAR, LLC
 102 GREENWICH AVENUE, 3FL
 GREENWICH, CT 06830

SOLAR ARRAY:
 MODULE: TRINA SOLAR TSM-PD14 310 72-CELL
 950 MODULES @ 310 WATTS EACH (294.50 kW DC @ STC)
 INSTALLED IN STRINGS OF 19 MODULES
 RACKING: DRIVEN POST GROUND MOUNT AT 20 DEG TILT
 INVERTER: SOLECTRIA PVI 36-TL (6 UNITS)

RITBA RI SOLAR, LLC
 102 GREENWICH AVE. 3FL
 GREENWICH, CT 06830
 12031698-0090



NEWPORT BRIDGE
 COVER SHEET
 PV SOLAR GROUND ARRAY
 1 EAST SHORE ROAD
 JAMESTOWN, RI 02835



A.P. 7, LOT 1
 N/F TOWN OF JAMESTOWN

ROUTE 138 - EAST PASSAGE CROSSING NARRAGANSETT BAY - NEWPORT BRIDGE

A.P. 7, LOT 171
 400521.0 Sq. Feet
 9.2 Acres

A.P. 7, LOT 760
 N/F FREEBODY, LLC

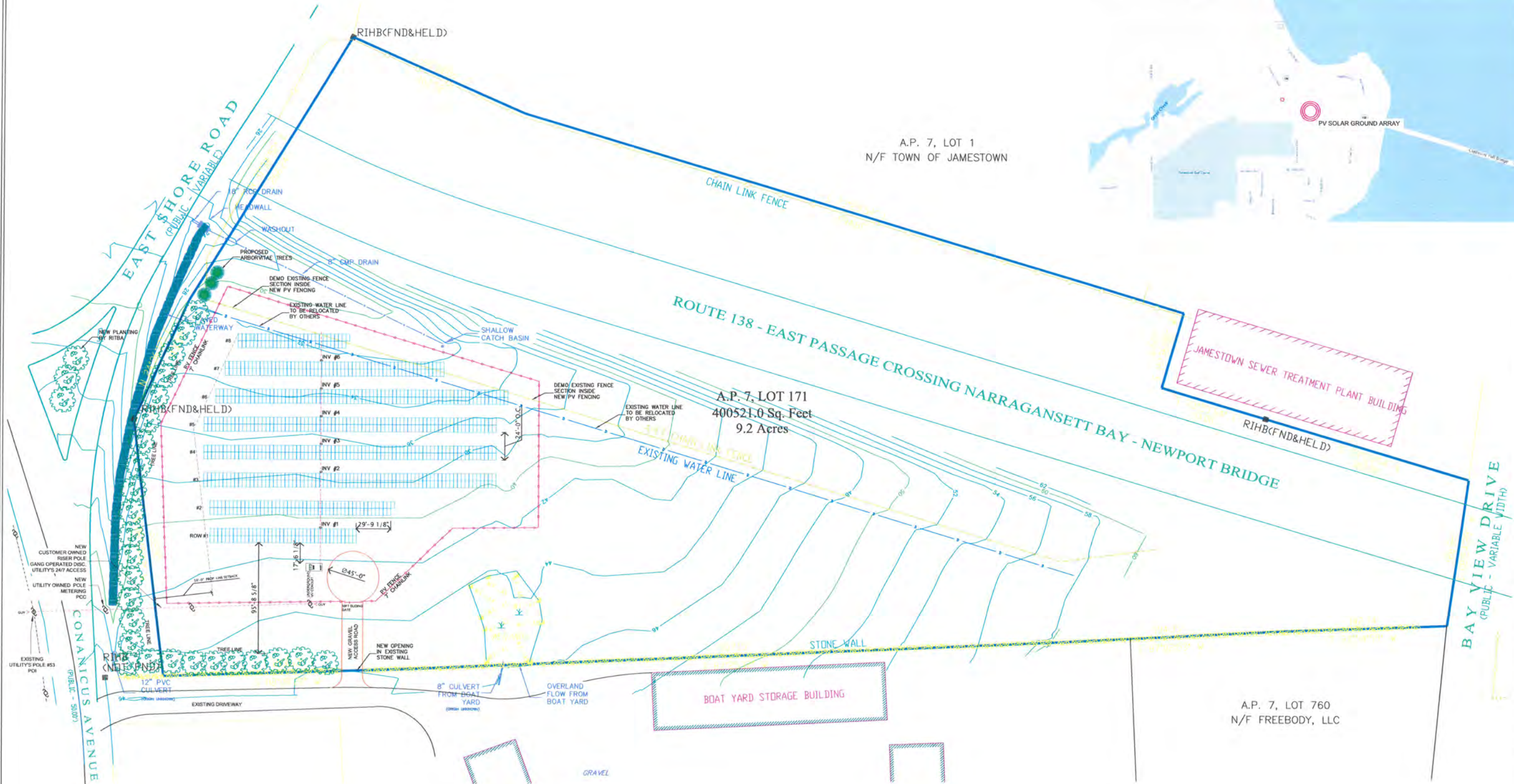

Scale: 1" = 40'

STAMP:

REVISIONS	
DATE:	COMMENT
9/7/16	PERMIT SET

JOB #	NEWPORT BRIDGE
DRWN	SD
CHKD	SG
SCALE	N.T.S
DATE	09-07-2016

C-1

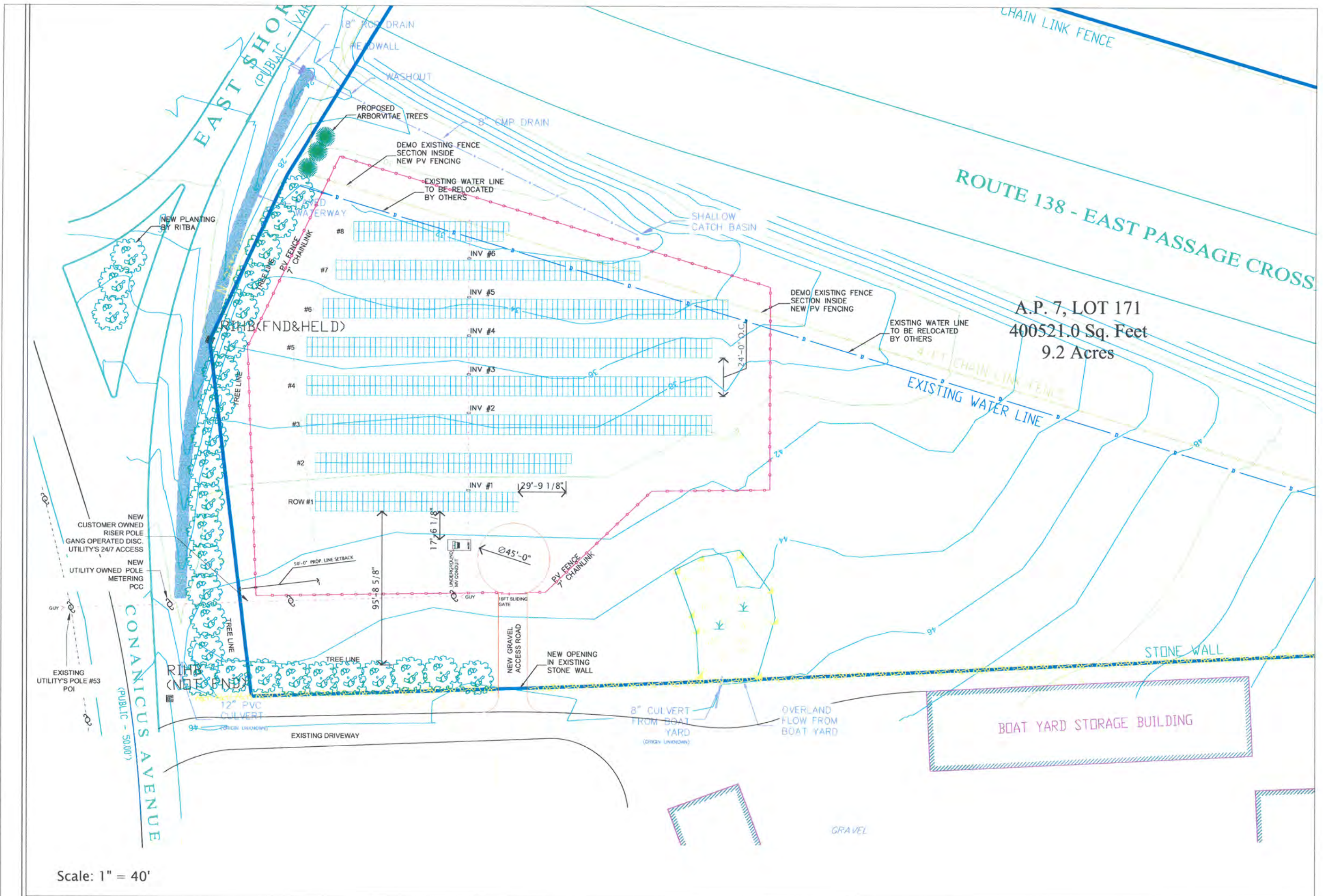

A.P. 7, LOT 171
 400521.0 Sq. Feet
 9.2 Acres

Scale: 1" = 40'

Newport Bridge

PV Solar Ground Array

1 East Shore Road
 Jamestown, RI

REVISIONS:

Scale: As Noted

Date: January 30, 2017

Drawn By: JCW

Landscape Plan 1

LA-1

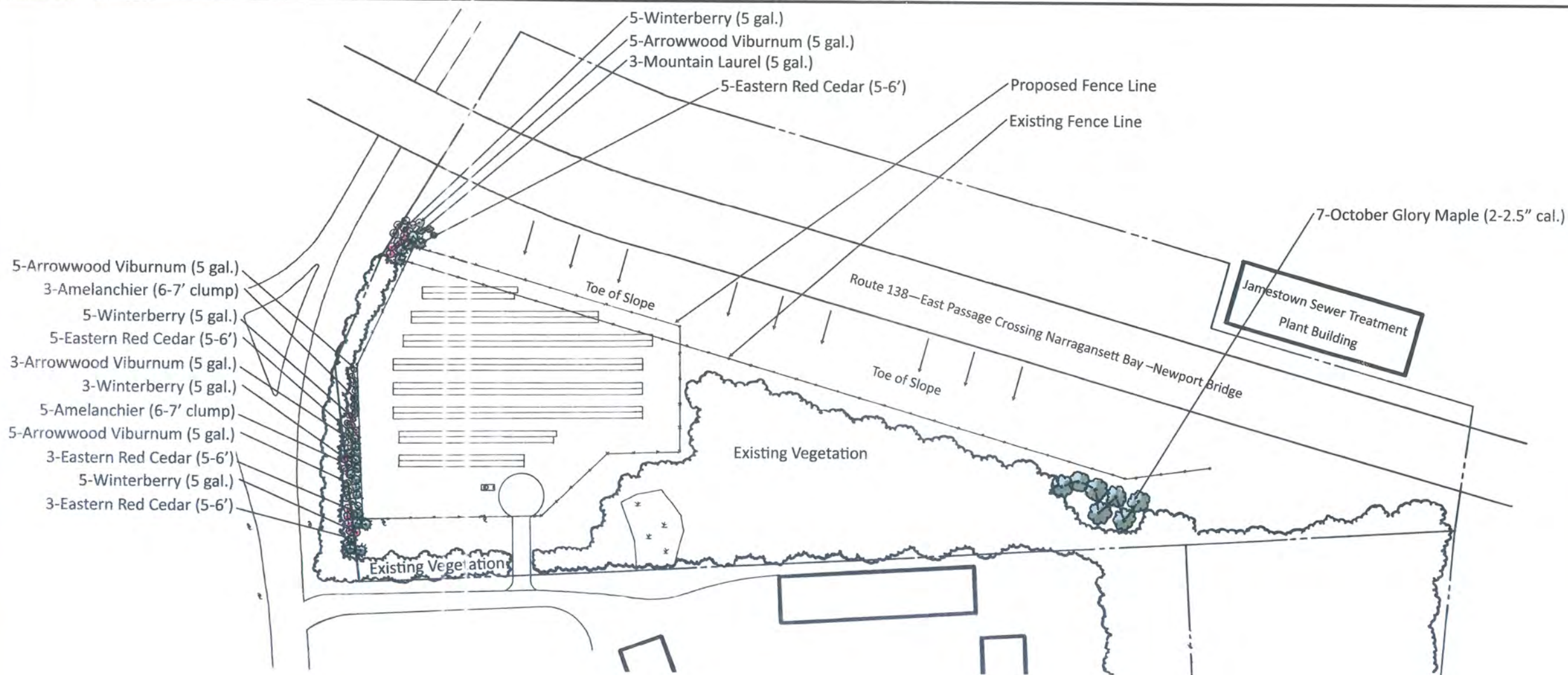

Overall Planting Layout

Scale: 1" = 60'-0"

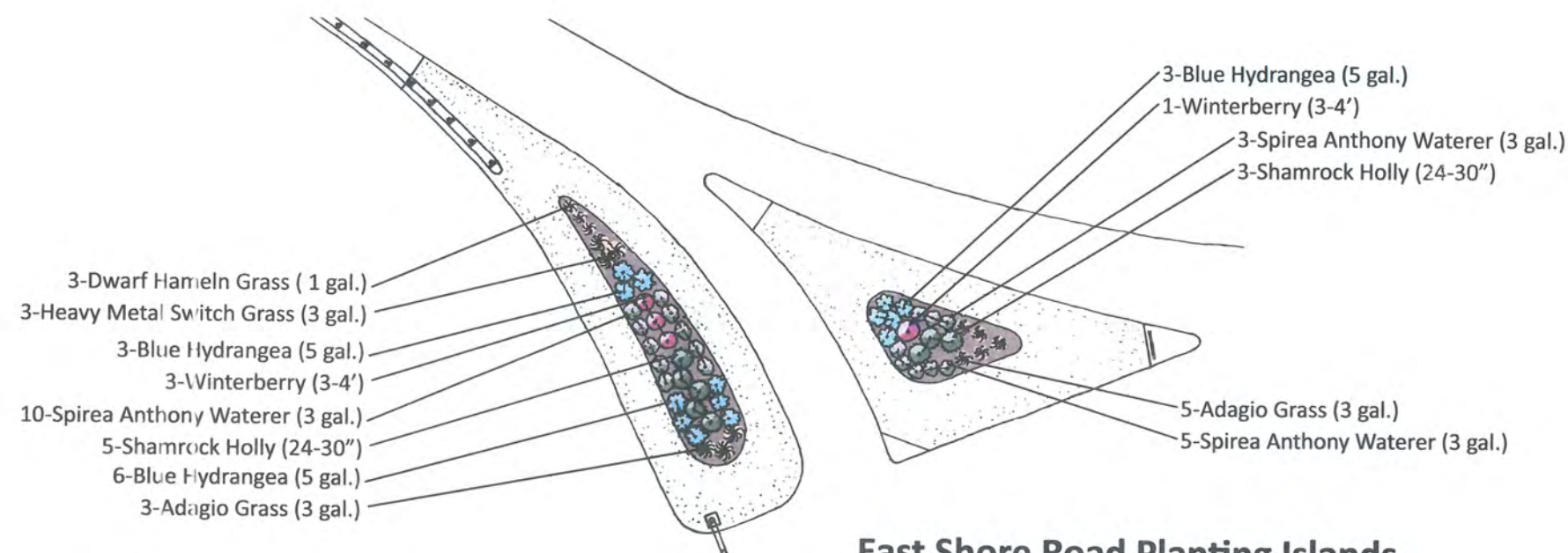

East Shore Road Planting Islands

Scale: 1" = 20'-0"

Solar Energy

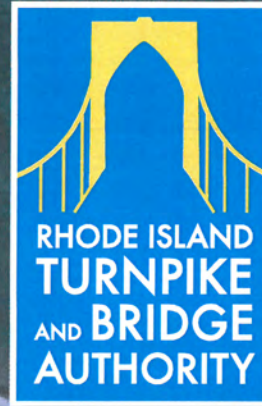

Proposed Site

★ Rhode Island Turnpike and Bridge Authority

★ Sewage Plant

★ Jamestown Highway Department

● PROPOSED SITE

★ RITBA Maintenance Area

Boatyard/Repair Facility

★ Jamestown Police Department

★ Jamestown Golf Course

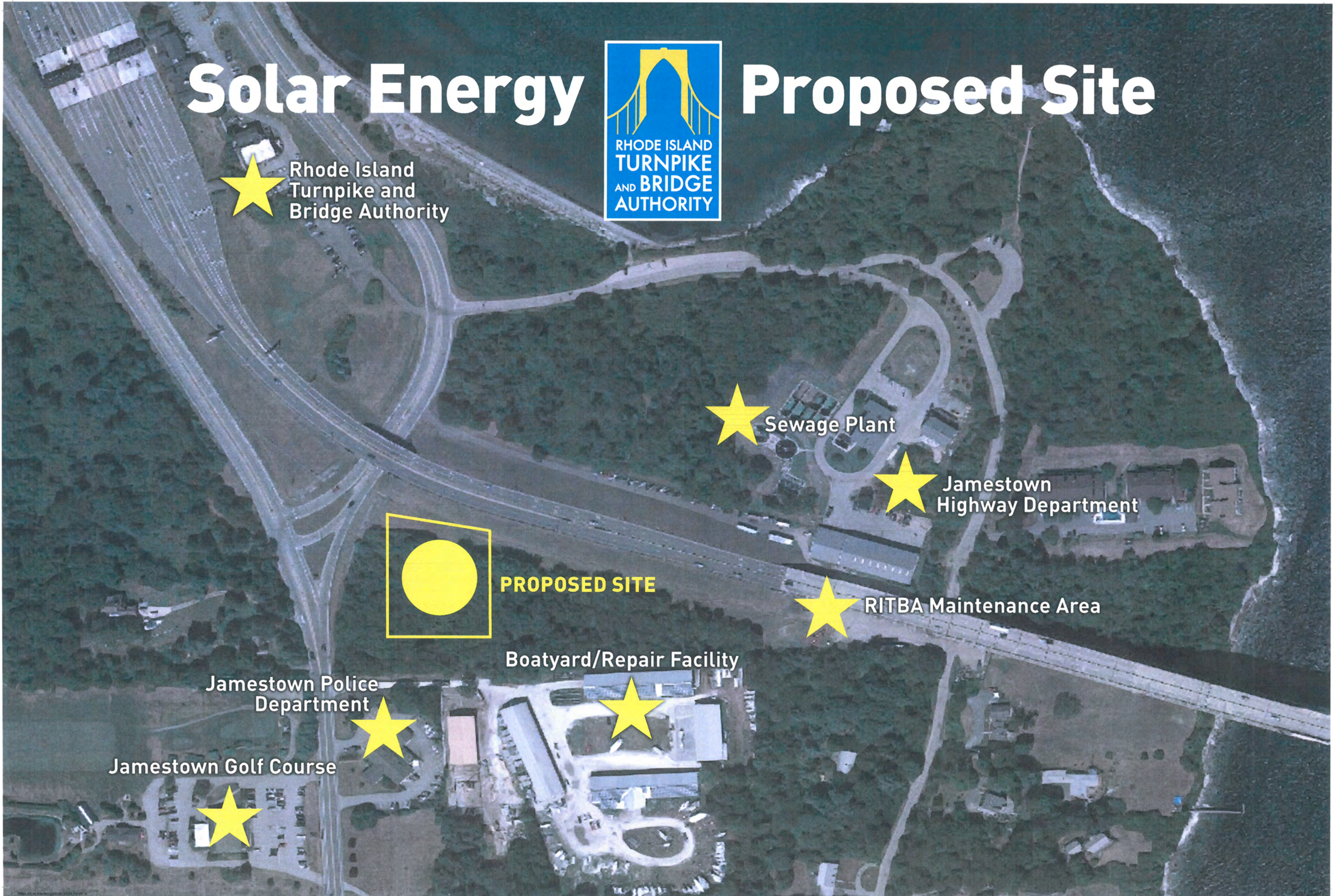

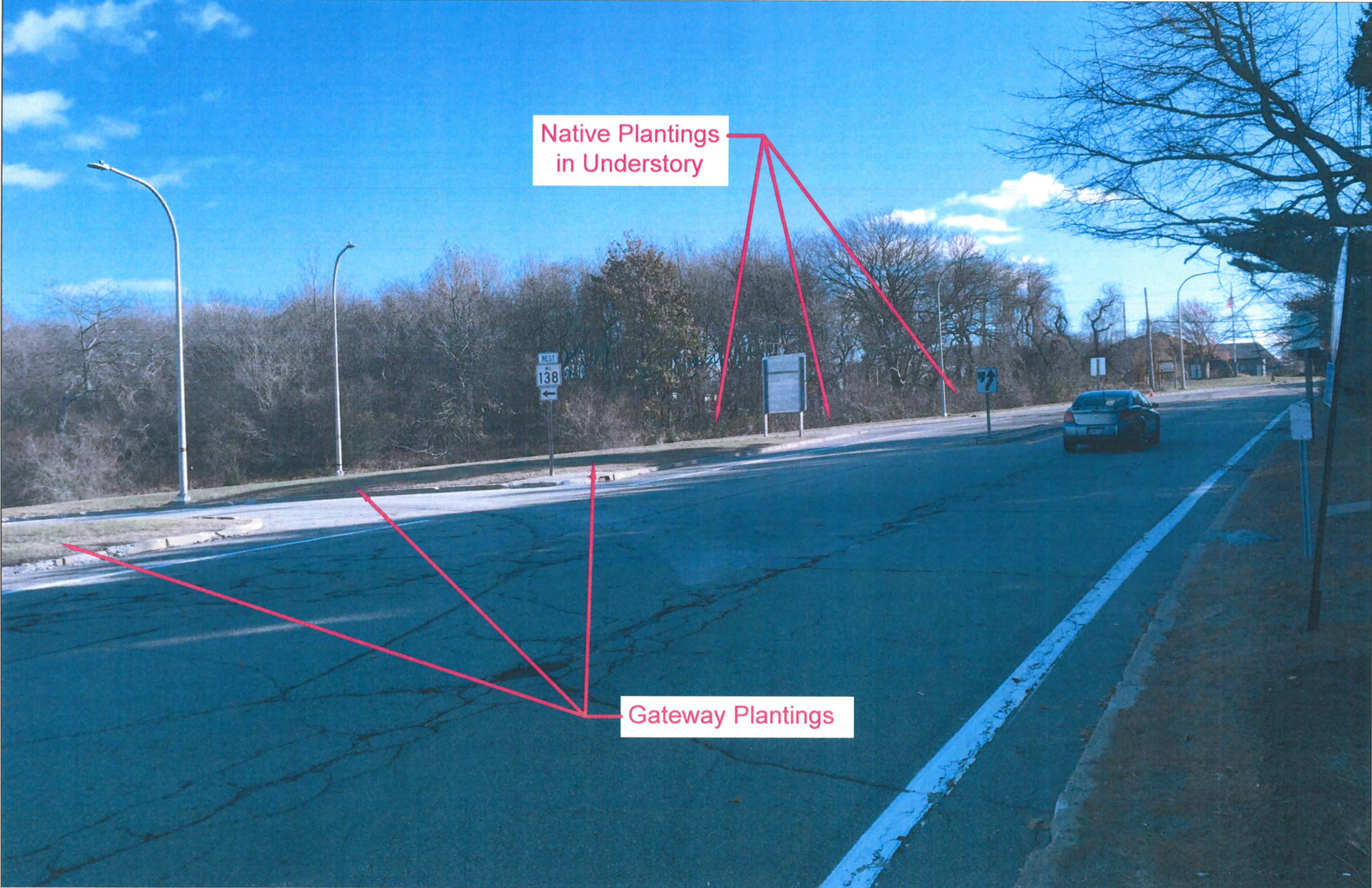

Native Plantings
in Understory

Gateway Plantings

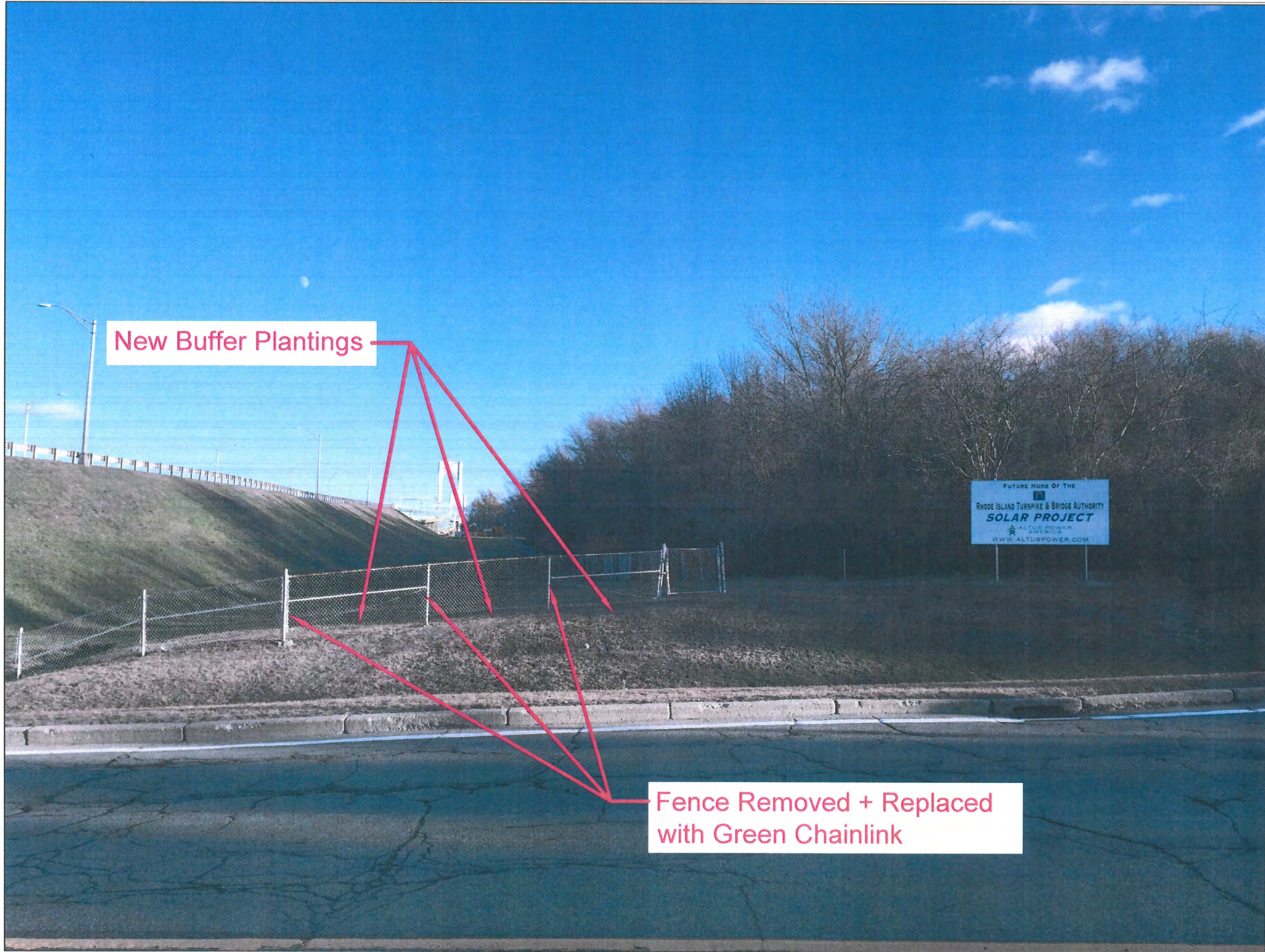

New Buffer Plantings

Fence Removed + Replaced with Green Chainlink



New Trees



Typical Array



Town of Jamestown
Resolution of the Town Council

No. 2017-02

Town of Jamestown

**“A RESOLUTION RELATIVE TO THE REGULATION OF
PROPERTY SUBJECT TO TAXATION
VETERANS EXEMPTION INCREASE”**

WHEREAS, the Town Council of the Town of Jamestown (the “Town”) has been desirous to make the Town a welcome and desirous place for veterans of the armed forces to make their homes; and

WHEREAS, if the Town were able to provide an additional adjustment of the property tax exemption for veterans, it would ease the tax burden on veterans; and

WHEREAS, under current state law, the Town is unable to exempt any further amount of property tax from local taxation other than is already provided in RIGL § 44-3-4; and

WHEREAS, the Town Council desires that the General Assembly authorize the Town to provide an additional adjustment of the tax exemption for any veteran who has been honorably discharged from military service, regardless of qualified service dates, pursuant to RIGL § 44-3-4.

NOW, THEREFORE, BE IT RESOLVED, that we, the Town Council of the Town of Jamestown, Rhode Island, respectfully requests that the General Assembly authorize the Town Council of the Town of Jamestown to replace the existing exemption to all honorably discharged veterans with a tax credit for any veteran, and his or her un-remarried widow or widower, who has been honorably discharged from military service, regardless of qualified service dates, pursuant to RIGL § 44-3-4; and

BE IT FURTHER RESOLVED, that we, the Town Council of the Town of Jamestown, respectfully requests that the General Assembly authorize the Town Council of the Town of Jamestown to replace the existing exemption to all veterans with One Hundred Percent (100%) service-connected disabilities with a tax credit for any disabled veteran with a One Hundred Percent service-connected disability, pursuant to RIGL §44-3-4; and

BE IT FURTHER RESOLVED, that the Town Clerk is hereby instructed to submit a copy of this Resolution to the Town of Jamestown’s State Senator and State Representative in the Rhode Island General Assembly in consideration of their support to submit an act to pass this amendment to become part of the Rhode Island General Laws.

By Order of the Jamestown Town Council

Kristine S. Trocki, President

Michael G. White, Vice President

Blake A. Dickinson

Mary E. Meagher

Eugene B. Mihaly

IN WITNESS WHEREOF, I hereby attach my hand and the official seal
of the Town of Jamestown this 21st day of February, 2017.

Cheryl A. Fernstrom, CMC, Town Clerk



Town of Jamestown

Resolution of the Town Council

No. 2017-03

Town of Jamestown

**“A RESOLUTION VALIDATING AND RATIFYING THE
TOWN OF JAMESTOWN CHARTER AMENDMENT
QUESTIONS APPROVED BY THE VOTERS AT THE
NOVEMBER 8, 2016 GENERAL ELECTION”**

WHEREAS, the General Election was held on Tuesday, November 8, 2016, and the voters approved passage of the ten (10) Charter Amendment questions on the Ballot, Exhibit A Certificate of the Town Clerk attached; and

WHEREAS, a Certification of the local Charter Amendment questions and results from the November 8, 2016 election were affirmed and signed by the Board of Canvassers on February 1, 2017, Exhibit B attached; and

NOW, THEREFORE, BE IT RESOLVED: that the Town Council of the Town of Jamestown validates and ratifies the certification and results of the local Charter Amendment questions that were voted at the November 8, 2016 General Election; and

NOW, THEREFORE, BE IT FURTHER RESOLVED: that the Town Council of the Town of Jamestown respectfully requests the General Assembly enact enabling legislation so that the amendments to the Jamestown Town Charter approved by the voters may be adopted and become part of the Jamestown Town Charter.

By Order of the Jamestown Town Council

Kristine S. Trocki, President

Michael G. White, Vice President

Blake A. Dickinson

Mary E. Meagher

Eugene B. Mihaly

IN WITNESS WHEREOF, I hereby attach my hand and the official seal
of the Town of Jamestown this 21st day of February, 2017.

Cheryl A. Fernstrom, CMC, Town Clerk



Town of Jamestown

Town Clerk's Office
Town Hall, 93 Narragansett Avenue
Jamestown, Rhode Island 02835-1199
401-423-7200 • Fax 423-7230
email: cfernstrom@jamestownri.net

Cheryl A. Fernstrom, CMC
Town Clerk
Probate Clerk

Exhibit A

Office of the Town Clerk CERTIFICATE

This is to certify that the following Charter Amendment questions were presented to the electorate of the Town of Jamestown on November 8, 2016 and the results were as follows:

TOWN OF JAMESTOWN LOCAL CHARTER AMENDMENT QUESTIONS TUESDAY, NOVEMBER 8, 2016

BALLOT QUESTIONS 8-17

QUESTIONS 8 – 17 AMENDMENTS TO THE JAMESTOWN TOWN CHARTER

Duly adopted by the Jamestown Town Council on the 19th day of July, 2016

8. Amends Article II. The Town Council § 206 – Special Meetings

Shall the Charter be amended to ensure that Special Meetings held by the Town Council fully comply with the current relevant state laws on open meetings?

Approve	3,096
Reject	207

9. Amends Article II, The Town Council, § 216 – Procedure for Adopting Ordinance

Shall the Charter be amended to modify the Town's procedure to publish an ordinance to allow for expanded notification to the public by publication of ordinance amendments on the Town's website?

Approve	2,947
Reject	306

10. Amends Article III, Town Administrator, § 301 – Appointments and Qualifications

Shall the Charter be amended to modify the qualifications of a Town Administrator candidate to include requirements for consistency in the hiring practice?

Approve	2,840
Reject	383

11. Amends Article IV, Administrative Departments, § 404 – Tax Assessor

Shall the Charter be amended to modify the qualifications of a Tax Assessor candidate to include requirements for consistency in the hiring practice?

Approve	2,797
Reject	412

12. Amends Article IV, Administrative Departments, § 405 – Board of Assessment Review

Shall the Charter be amended to delete any party designation requirements for Board of Assessment Review candidates?

Approve	2,328
Reject	840

13. Amends Article IV, Administrative Departments, § 406 – Town Moderator

Shall the Charter be amended to modify the replacement of the Town Moderator by the Town Council should a vacancy occur during a Moderator's term of office?

Approve	2,680
Reject	561

14. Amends Article IV, Administrative Departments, § 422 – Library Trustees

Shall the Charter be amended to modify the Charter by removing the reference to the Library Trustees as it is no longer relevant?

Approve	2,772
Reject	456

15. Amends Article V, Schools, §503 – Vacancies

Shall the Charter be amended to revise the replacement of a School Committee member to include the next highest vote getter upon a vacancy occurring during a term of office?

Approve 2,731
Reject 542

16. Amends Article VIII, Miscellany, § 805 – Elected Officials

Shall the Charter be amended to replace the obsolete term of ambulance with emergency medical service?

Approve 2,857
Reject 406

17. Amends Article X, Boards, Commissions and Committees, § 1002 – Membership and Terms

Shall the Charter be amended to provide an exception to the term limit provisions for appointments to allow the retention of a key committee member with specific qualifications?

Approve 2,050
Reject 1,174

IN WITNESS WHEREOF, I hereby attach my hand and the official seal
Of the Town of Jamestown this 21st day of February, 2017

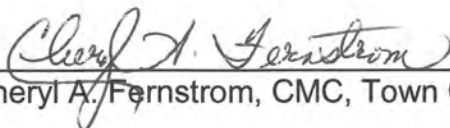

Cheryl A. Fernstrom, CMC, Town Clerk





Town of Jamestown

Town Clerk's Office
Town Hall, 93 Narragansett Avenue
Jamestown, Rhode Island 02835-1199
401-423-7200 • Fax 423-7230
email: cfernstrom@jamestownri.net

Cheryl A. Fernstrom, CMC
Town Clerk
Probate Clerk

Exhibit B

The Board of Canvassers for the Town of Jamestown, Rhode Island hereby certify that the foregoing document is the Final Official Results for the voting of the November 8, 2016 election for the Town of Jamestown.

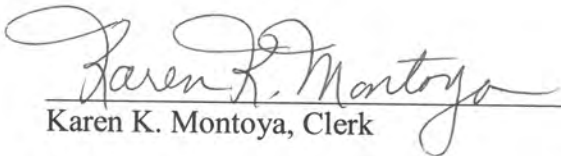

Karen K. Montoya, Clerk

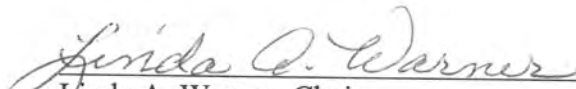

Linda A. Warner, Chair



Carol Nelson-Lee

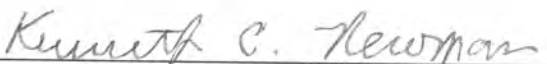

Kenneth C. Newman

WITNESS my hand and the official seal of the Town of Jamestown, County of Newport, State of Rhode Island this 1st day of February, A.D. 2017.



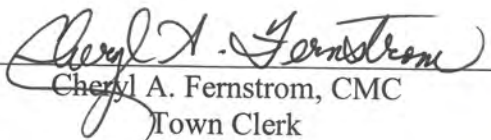

Cheryl A. Fernstrom, CMC
Town Clerk



1
2
3
4
5
6
7
8
9
10
11
12
13
14
15
16
17
18
19
20
21
22
23
24
25
26
27
28
29
30
31
32

PUBLIC HEARING NOTICE
TOWN OF JAMESTOWN

Notice is hereby given that the Town Council of the Town of Jamestown will conduct a public hearing on March __, 2017 at ___ p.m. at the Jamestown Town Hall, 93 Narragansett Avenue on the following proposed amendment to the Code of Ordinances regarding Chapter 38 – Offenses and Miscellaneous Provisions, Article V - Weapons. Opportunity shall be given to all persons interested to be heard upon the matter at the public hearing. The following proposed ordinance amendment is under consideration and may be adopted and/or altered or amended prior to the close of the public hearing without further advertising, as a result of further study or because of the views expressed at the public hearing. Any alteration or amendment must be presented for comment in the course of the public hearing. The proposed amendment is available for review and/or purchase at the Town Clerk’s Office between the hours of 8:30 a.m. and 4:30 p.m., Monday through Friday, excluding Holidays and on the Town’s web site at www.jamestownri.gov.

Section 1. Be it hereby ordained by the Town Council of the Town of Jamestown that the Jamestown Code of Ordinances, Chapter 38, as the same may have been heretofore amended, is hereby amended by changing the text of the Chapter, as follows:

NOTE: words set as ~~striketrough~~ are to be deleted from the ordinance; words underlined are to be added to the ordinance.

See Exhibit A, attached hereto and incorporated herein by reference.

Section 2. The Town Clerk is hereby authorized to cause said changes to be made to Chapter 38 of the Town of Jamestown’s Code of Ordinances.

Section 3. This Ordinance shall take effect upon its passage.

Ad Date(s): _____

Publication Source: Jamestown Press

Hearing Date: _____

Action: _____

Certified: _____

1 **Exhibit A**

2 **Sec. 38-111. - Use of rifled firearm while hunting.**

3 No person shall, while hunting within the town, use a rifled firearm, other than a shotgun
4 outfitted with a rifled barrel or a muzzleloader with a rifled barrel.

5 **Sec. 38-112. Definitions.**

6 The following definitions shall have the following meanings for the purposes of this chapter:

7 “Building”: any structure used or intended for supporting or sheltering any use or occupancy,
8 including but not limited to a dwelling, and or accessory building or structure.

9 “Discharge”: the operation of a firearm as to cause the ignition of the powder charge with or
10 without the expulsion of a projectile from the firearm.

11 "Firearm": includes any machine gun, pistol, rifle, air rifle, air pistol, "blank gun," "BB gun," or
12 other instrument from which steel or metal projectiles are propelled, or which may readily be
13 converted to expel a projectile, except crossbows, recurve, compound, or longbows, and except
14 instruments propelling projectiles which are designed or normally used for a primary purpose
15 other than as a weapon. The frame or receiver of the weapon shall be construed as a firearm
16 under the provisions of this section.

17 “Recreational Target Range”: a non-commercial target range which may be located indoors or
18 outdoors to practice the discharge of weapons aimed at a target.

19 **Sec. 38-113 Firearm Discharge.**

20 Conanicut Island is determined and declared to be a compact area as that term is set forth
21 pursuant to the relevant provisions of the R.I. General Laws at Title 11, Chapter 47, Section 50,
22 as amended. No person, not being at the time under police or military duty, shall Discharge any
23 Firearm on Conanicut Island in the Town of Jamestown.

24 **Sec 38-114. Use of weapons in self-defense and hunting.**

25 No provision of this chapter shall be construed as prohibiting the use of Firearms by licensed
26 armed guards or by private persons in the Town for the protection or defense of person or
27 property and/or hunting in accordance with applicable provisions of the General Laws.

28 **Sec. 38-115. Enforcement.**

29 Any person violating the provisions of this section shall be punished as provided in Section 1-15.

1
2
3
4
5
6
7
8
9
10
11
12
13
14
15
16
17
18
19
20
21
22
23
24
25
26
27
28
29
30
31
32

PUBLIC HEARING NOTICE
TOWN OF JAMESTOWN

Notice is hereby given that the Town Council of the Town of Jamestown will conduct a public hearing on March __, 2017 at ___ p.m. at the Jamestown Town Hall, 93 Narragansett Avenue on the following proposed amendment to the Code of Ordinances regarding Chapter 38 – Offenses and Miscellaneous Provisions, Article V - Weapons. Opportunity shall be given to all persons interested to be heard upon the matter at the public hearing. The following proposed ordinance amendment is under consideration and may be adopted and/or altered or amended prior to the close of the public hearing without further advertising, as a result of further study or because of the views expressed at the public hearing. Any alteration or amendment must be presented for comment in the course of the public hearing. The proposed amendment is available for review and/or purchase at the Town Clerk’s Office between the hours of 8:30 a.m. and 4:30 p.m., Monday through Friday, excluding Holidays and on the Town’s web site at www.jamestownri.gov.

Section 1. Be it hereby ordained by the Town Council of the Town of Jamestown that the Jamestown Code of Ordinances, Chapter 38, as the same may have been heretofore amended, is hereby amended by changing the text of the Chapter, as follows:

NOTE: words set as ~~striketrough~~ are to be deleted from the ordinance; words underlined are to be added to the ordinance.

See Exhibit A, attached hereto and incorporated herein by reference.

Section 2. The Town Clerk is hereby authorized to cause said changes to be made to Chapter 38 of the Town of Jamestown’s Code of Ordinances.

Section 3. This Ordinance shall take effect upon its passage.

Ad Date(s): _____

Publication Source: Jamestown Press

Hearing Date: _____

Action: _____

Certified: _____

1 **Exhibit A**

2 **Sec. 38-111. - Use of rifled firearm while hunting.**

3 No person shall, while hunting within the town, use a rifled firearm, other than a shotgun
4 outfitted with a rifled barrel or a muzzleloader with a rifled barrel.

5 **Sec. 38-112. Definitions.**

6 The following definitions shall have the following meanings for the purposes of this chapter:

7 “Building”: any structure used or intended for supporting or sheltering any use or occupancy,
8 including but not limited to a dwelling, and or accessory building or structure.

9 “Discharge”: the operation of a firearm as to cause the ignition of the powder charge with or
10 without the expulsion of a projectile from the firearm.

11 "Firearm": includes any machine gun, pistol, rifle, air rifle, air pistol, "blank gun," "BB gun," or
12 other instrument from which steel or metal projectiles are propelled, or which may readily be
13 converted to expel a projectile, except crossbows, recurve, compound, or longbows, and except
14 instruments propelling projectiles which are designed or normally used for a primary purpose
15 other than as a weapon. The frame or receiver of the weapon shall be construed as a firearm
16 under the provisions of this section.

17 “Recreational Target Range”: a non-commercial target range which may be located indoors or
18 outdoors to practice the discharge of weapons aimed at a target.

19 **Sec. 38-113 Firearm Discharge.**

20 Conanicut Island is determined and declared to be a compact area as that term is set forth
21 pursuant to the relevant provisions of the R.I. General Laws at Title 11, Chapter 47, Section 50,
22 as amended, except for those areas of the Island with the zoning designation of RR-200 or RR-
23 80, as set forth in the Jamestown Code of Ordinances, Chapter 82 – Zoning, at 82-301 and the
24 Official Zoning Map, as amended. No person, not being at the time under police or military duty,
25 shall Discharge any Firearm on Conanicut Island in the Town of Jamestown, except as follows:

- 26 1. Legal hunting activity as defined by state and local regulations.
- 27 2. Target shooting on private property by the property owner or guest with written
28 permission of the property owner on a Recreational Target Range.
- 29 3. Use of a Recreational Target Range is restricted to the time period between 10:00 AM
30 to 6:00 PM, Wednesday through Saturday; provided, however, that all activity must
31 cease 30 minutes before sunset on a year-round basis.
- 32 4. All prudent safety measures shall be exercised to protect the public health, safety and
33 welfare.
- 34 5. The point of Discharge of any Firearm and the point of impact from any target, berm
35 or backstop shall be a minimum distance of 500’ feet from any Building.
- 36 6. The point of Discharge of any Firearm and the point of impact from any target, berm
37 or backstop may be less than that set forth in paragraph 5, supra, if, and only if, the

1 owner or owners of any Building within 500' from the point of Discharge and the
2 point of impact from a target, berm or backstop provides written permission for the
3 point of Discharge and the point of impact from any target, berm or backstop being
4 less than that required.

- 5 7. In no case shall any target, berm or backstop be located greater than 100' from any
6 point of Discharge of any Firearm.

7
8 No person shall Discharge any Firearm in such fashion that the shot, bullets, arrows, darts or
9 other missiles shall in their flight carry over, along or across the land of another, any public
10 roadway, designated public walking path, access way, sidewalk, hiking trail, park area, or bike
11 path, into which they shall not have written permission of the owner and occupant thereof to
12 shoot. Such written permission shall be carried on the person at all times when engaged in the
13 activity and shall be shown and exhibited upon request by the police.

14 **Sec 38-114. Use of weapons in self-defense and hunting.**

15 No provision of this chapter shall be construed as prohibiting the use of Firearms by licensed
16 armed guards or by private persons in the Town for the protection or defense of person or
17 property and/or hunting in accordance with applicable provisions of the General Laws.

18 **Sec. 38-115. Enforcement.**

19 Any person violating the provisions of this section shall be punished as provided in Section 1-15.

**TOWN COUNCIL MEETING
February 6, 2017**

I. ROLL CALL

Town Council Members present:

Michael G. White, Vice President
Blake A. Dickinson
Mary E. Meagher
Eugene B. Mihaly

Town Council Members absent:

Kristine S. Trocki, President

Also in attendance:

Andrew E. Nota, Town Administrator
Christina D. Collins, Finance Director
Lisa W. Bryer, Town Planner
Michael C. Gray, Public Works Director
Edward A. Mello, Police Chief
Andrew J. Wade, Parks and Recreation Director
Peter D. Ruggiero, Town Solicitor
Cheryl A. Fernstrom, Town Clerk

II. CALL TO ORDER, PLEDGE OF ALLEGIANCE

Council Vice President White called the regular meeting of the Jamestown Town Council to order at 7:00 p.m. in the Jamestown Town Hall Rosamond A. Tefft Council Chambers at 93 Narragansett Avenue, and Councilor Dickinson led the Pledge of Allegiance.

**III. TOWN COUNCIL SITTING AS THE BOARD OF
WATER AND SEWER COMMISSIONERS**

None.

**IV. ACKNOWLEDGEMENTS, ANNOUNCEMENTS, RESOLUTIONS
AND PROCLAMATIONS**

A) Presentations

- 1) FY 2016 (July 1, 2015 – June 30, 2016) Audit Report: Paul Dansereau, CPA of Baxter Dansereau & Associates

Mr. Dansereau addressed the Council regarding the FY 2016 Audit, thanking Finance Director Christina Collins and staff and School Department Director of Finance Jane Littlefield and staff for their assistance. Audited Statements were filed within the time required by law (6 months after the end of the fiscal year). The Auditor's unmodified opinion was reviewed and an explanation of the Statement of Net Position (Balance

Sheet, Page 14), Statement of Activities (Profit and Loss Statement, Page 15), Balance Sheet and Statement of Revenues and Expenses on a full accrual basis (Pages 16 and 17), and Statement of Revenues, Expenses and Changes in Fund Net Position and Statement of Cash Flows for the Enterprise Funds (Pages 20 and 21) proceeded. Other areas reviewed were: Balance Sheet for Funds Combined with General Fund for GASB 54 Purposes as required by law (Page 116), Special Revenue Restricted Funds (Page 99), Statement of Net Position for Proprietary Funds (Page 19) and Notes to Financial Statements Note 1 through Note 15 (Pages 24 to 78), which include Retirement Systems and OPEB. Finance Director Collins and Auditor Dansereau commented the Town had a good year and offer to answer questions at any time. The Audited Financial Statements will be available on the Town website in its entirety tomorrow morning.

V. PUBLIC HEARINGS, LICENSES AND PERMITS

None.

VI. OPEN FORUM

Please note that, under scheduled requests to address, if the topic of the address is available to be put on the agenda, the Council may discuss the issue

A) Scheduled to address

- 1) Mark Baker of the Jamestown Sanctuary Group; request for support for enactment of a local Sanctuary Ordinance

Mark Baker of Baldwin Court asked the Council to review the information provided this evening and create an ordinance. This should be considered our “Gaspee Moment” like the 200 communities across America that have considered such an ordinance. Discussion ensued of police powers, fundamentals of democracy, and protection of our citizens, with references to RI Founder Roger Williams and others. Mr. Baker stated it is important for our community to get involved, protect our citizens, and do the right thing, as our basic beliefs are being challenged. He asks the Council to develop and adopt a Sanctuary Ordinance.

Councilor Dickinson asked what specific actions caused a necessity for an ordinance, as he doesn’t know of any policies abusive to anyone and he would be upset if there were. Mr. Baker referenced the Federal Immigration Database and the current administration’s request that local police check the immigration status of individuals at will, which is persecution without due process. Councilor Dickinson commented on the request for identification, which is asked of all citizens not just immigrants. He also noted his background in the development of processes between the State Department, FBI, Homeland Security and local law enforcement agencies, and any person detained by local authorities is given the same rights, whether they are citizens or immigrants.

B) Non-Scheduled to address

Thomas Bembenek of Green Lane stated his opposition to Mr. Baker’s proposal. He referenced his Polish family’s emigration (great great grandparents in 1856) from Germany to escape persecution and his Italian great grandparents in the early 20th century for a better life. They were well documented and entered legally. He noted the

Constitution protects all legitimate inhabitants of this nation, we don't need a special ordinance to protect us, we are a nation of immigrants and laws, and it is unfair to provide sanctuary to those who enter our country illegally and do not respect our laws. He urged the Town Council to apply common sense and reject this request for an ordinance.

Vice President White stated we have two opinions, there is no vote, and the Council will take this under advisement, review this issue further, and address it at a later date.

Johannes Von Guppenberg of Bay Street commented he came here as an immigrant and most countries are made up of immigrants. He gave his historical perspective on immigration, stated what is being proposed is dangerous, referenced comparisons to history, and stated uncontrolled immigration is dangerous.

Helen Allen of Wakefield commented on the upcoming President's Day observance and stated it does not honor General Washington, the original intention of the observance of February 22, which should be declared as Washington's Birthday. She invited the Town Council and the Jamestown Historical Society to recognize the date of Washington's Birthday and participate in an event commemorating it.

Jessica McCarthy of Beach Avenue commented she is here with her children to teach them about local government. She questioned whether immigrants should just move in without waiting, and gave an analogy to waiting in line and having others cut to the front of the line. She asked what federal laws need to be followed and which don't, and thanked the Council for the opportunity to observe local government.

Janet Von Guppenberg of Bay Street commented it is her opinion Federal immigration laws are unsuitable for the needs of our country. If there is a problem with immigration laws, energies should be directed towards changing outdated laws through proper legislation in Congress instead of setting-up side efforts that delay proper action.

Stefan Gislason of Beavertail Road stated he is in favor of the sanctuary effort and thanked everyone for expressing their opinions. He referenced more lenient immigration laws of the past and controversies when many refugees were turned away. This is an issue of optional local cooperation with federal law and recruiting local police to take on the function of immigration agents, which may take resources from local issues. Any immigrant who is the victim of a crime should not be afraid to go to the local police, and being here illegally is not a criminal violation, but a civil violation.

Vice President White thanked everyone for their comments and encourages all to speak to this in the future when it appears on the agenda. He asked for any additional comments on a different subject.

VI. COUNCIL, ADMINISTRATOR, SOLICITOR, COMMISSION/COMMITTEE COMMENTS & REPORTS

A) Jamestown Fire Department: Deputy Chief Howard Tighe

1) Business Licensing

Deputy Chief Howard Tighe referenced his memos and information on inspections and licensing. All required inspections were completed on time, prior to the November Council meeting. The proposed revisions to the licensing process by the Council were noted and JFD wants to be part of that process. Any establishments found to be deficient per the Fire Code are closed and dealt with on an individual basis, with notification to Town Administration.

Councilor Meagher referenced the agenda and that all information is posted on the Town website. She referenced Deputy Chief Tighe's memo and the clarity of the inspection process outlined. She confirms he does his job very well and thanked him for that. Councilor Mihaly stated he agrees with every word by Councilor Meagher.

2) New EMS Protocols

Deputy Chief Tighe stated for the first time in 30 years there is a complete revision of the EMS protocols. The new cardiac arrest protocol requires EMS responders to remain on scene and perform CPR for a minimum of 30 minutes, which seems like a long time. However, the survival rate rises by staying on scene. During this period there is contact with a physician at Newport Hospital, and there is a potential direction to continue CPR for an additional 15 minutes based on that contact, for a total of 45 minutes. The new protocol will change the services provided, requiring perhaps eight to nine emergency responders compared to the current two to three that man the rescue vehicle, and include the need for a fire truck with the additional personnel. The increased emergency service time and additional personnel may also require additional police services at the scene. The new protocols, effective as of March 1, 2017, will ultimately result in an increased survival rate.

At the request of Councilor Mihaly, Deputy Chief Tighe described changes in EMS services since JFD achieved ALS certification in 2015 that provide advanced life saving measures, including medications and transportation to the most appropriate medical facility, with no delay in care. Last year EMS responded to six cardiac arrest calls and 47 chest pain calls. ALS combined with the new protocol will provide the highest level of care and highest chance of survival rate. Discussion continued.

B) Jamestown Affordable Housing Committee – affordable housing lots in the Village: Town Planner Lisa Bryer

Town Planner Lisa Bryer reported on the review of potential affordable housing lots in the village. There are twenty-four (24) lots identified that could be subdivided for affordable housing. The next step is to mail individualized letters to the homeowners describing the opportunity and encouraging them to contact the Planning Office for further information. The lots identified are too small for traditional subdivision, but would be allowed for affordable housing under Sec. 82-1104 of the Zoning Ordinance, where 8,000 sq ft. minimum lot size is required, and 6,000 sq. ft. lot size allowed for

affordable housing. This option may also allow citizens, particularly seniors, to remain in their homes by subdividing their properties for the purposes of affordable housing. Discussion ensued.

VIII. UNFINISHED BUSINESS

- A) Adoption of the FEMA approved 2017 Town of Jamestown Hazard Mitigation Plan; review and discussion and/or potential action and/or vote
- 1) Adoption of Resolution No. 2017-01

Town Planner Bryer referenced the draft Hazard Mitigation Plan adopted by the Council at the public hearing in October 2014. The Plan was forwarded to RIEMA and FEMA for review and recommendation for approval, and it is back before Council for final approval. Planner Bryer noted Chief Mello's efforts in this approval process. Adoption of a final plan will confirm Jamestown's eligibility to apply for Mitigation grants administered by FEMA. The revisions to the Plan were provided in the Council packet, and a full text of the Plan is available on the Town website.

Council members asked if the Plan identifies the location of elderly housing and special needs facilities. Chief Mello noted this information is covered under the Emergency Operations Plan, and the RI Department of Health maintains an updated list of residents at risk, and those (90) individuals are contacted by phone or face-to-face visits during an emergency. No medical information is required on the listings and they are used for contact purposes during an emergency. Vice President White read the adopting Resolution No. 2017-01

A motion was made by Councilor Mihaly with second by Councilor Meagher to approve the Resolution. President Trocki, Absent; Vice President White, Aye; Councilor Dickinson, Aye; Councilor Meagher, Aye; Councilor Mihaly, Aye.

- B) Upcoming Meetings and Sessions – dates and times

Town Administrator Nota reviewed scheduled sessions and noted available dates for Operating Budget review (2), Capital Budget review, and School Budget review, and two additional dates for review, if needed, with FY 2017-2018 Budget adoption scheduled for the April 17th Council Meeting. Budget Sessions and meetings were scheduled as follows:

Town Council Meeting	March 6 th
Town Administrator's Budget Submittal	March 6 th
Capital Budget Hearing	March 9 th
Town Council Meeting	March 20 th
Operating Budget Hearings	March 21 st and 23 rd
School Budget Hearing	March 30 th
Town Council Meeting	April 3 rd
Budget Review Hearings, if needed	April 6 th and 13 th
Town Council Meeting	April 17 th

Discussion ensued. The RITBA Solar Array and notice of advertising for the Target Shooting Ordinances will be on the Tuesday, February 21st Town Council Meeting agenda. The Veterans Exemption, which requires General Assembly approval for enabling legislation, will appear on an upcoming agenda.

IX. NEW BUSINESS

- A) Design Alternatives for East Ferry Renovation Project; review and discussion and/or potential action and/or vote

Public Works Director Michael Gray reported on the ongoing enhancement project, improvements to date, and design alternatives for East Ferry. Landscape architect Hali Beckman of Jamestown was engaged to look at existing conditions and make recommendations to improve the available spaces.

Hali Beckman of Hali Beckman Ltd. gave a PowerPoint presentation for Scheme 1 showing existing layout and conditions, referencing vistas along the route to East Ferry, preservation of the 46 parking spaces, green space, waterfront and bridge views, and landscaping. Proposed walkway, retaining wall, new benches, lighting, boardwalk, enhanced ferry area, and plantings were noted.

Rosemary Enright of Clarke Street, Jamestown Historical Society Treasurer, suggested relocation of the Roger Williams stone.

Don Richardson of Davis Street asked for further delineation of the area and proposed changes.

Ms. Beckman noted proposed sustainable, native plantings, moved light poles, and low shrubbery for enhanced views.

Scheme 2 was reviewed, which includes a retaining wall (to also provide seating), new parking lot surface, relocated green space adjacent to the waterfront, shoreline walkway, landscaped parking islands, sidewalks and curbs. The goal is an aesthetically pleasing, usable area.

Public Works Director Gray gave further explanation of the proposed changes including the ferry landing and repairs to the surface, riprap, re-pointing, and resurfacing. The proposed enhancements will be ADA compliant. Ms. Beckman noted the design was developed with CRMC guidelines in mind. Discussion continued, including location of the sidewalk.

Parks and Recreation Director Andy Wade commented on the designs and efforts by Ms. Beckman and Environmental Scientist Jean Lambert. He would be proud to maintain the enhancements proposed in Scheme 2.

Don Richardson of Davis Street expressed the opinion the area is fine the way it is and should remain the same. He noted concern a hurricane would wash away the proposed vegetation.

Council members noted these are proposed preliminary ideas and public feedback is helpful. Discussion ensued of vehicle access and the goal for a pedestrian friendly, aesthetically pleasing area. Lengthy discussion continued.

A motion was made by Councilor Mihaly with second by Councilor Meagher to have further exploration of Scheme 2.

Discussion. Councilor Dickinson expressed concern for access, sensitivity to Mr. Richardson's remarks, and concern for handicapped parking placement. Vice President White noted accessibility to businesses in the East Ferry area. Sean (inaudible last name) stated it seems like a lot of maintenance for small green spaces. Ms. Beckman suggested ornamental grasses for the area to create a balance. Councilor Meagher commented it makes sense to put the park by the water and she appreciates the improved parking and the balance created. Gayen Thompson likes salt water tolerant vegetation and commented on use of the town's limited water supply for vegetation maintenance. Town Planner Bryer stated Scheme 2 is the preferred configuration. Don Richardson asked if the Traffic Committee has seen this. Council members noted this is preliminary, and they will see it.

Back to the vote on the motion. **President Trocki, Absent; Vice President White, Aye; Councilor Dickinson, Aye; Councilor Meagher, Aye; Councilor Mihaly, Aye.**

- B) Award of Bid: Timber Dolphin Repairs Project at West Ferry to Narragansett Dock Works, Inc. for an amount not to exceed \$37,500.00 as recommended by Public Works Director Michael C. Gray; review and discussion and/or potential action and/or vote

Public Works Director Gray explained the project to date and the need to get it done prior to the 2017 season. There were three bidders for the contract.

A motion was made by Councilor Meagher with second by Councilor Mihaly to award this bid to Narragansett Dock Works, Inc. for \$37,500. President Trocki, Absent; Vice President White, Aye; Councilor Dickinson, Aye; Councilor Meagher, Aye; Councilor Mihaly, Aye.

- C) Letters from Canvassing Clerk Karen Montoya requesting authorization to begin the appointment process for Board of Canvassers Member and Alternate Member, pursuant to RIGL §17-8-1 and RIGL §17-8-2; review and discussion and/or potential action and/or vote
 - 1) Jamestown Board of Canvassers (Two vacancies - One Member and One Alternate Member with six-year term ending dates of March 1, 2016)

A motion was made by Councilor Mihaly with second by Councilor Meagher to proceed. President Trocki, Absent; Vice President White, Aye; Councilor Dickinson, Aye; Councilor Meagher, Aye; Councilor Mihaly, Aye.

X. ORDINANCES AND APPOINTMENTS AND VACANCIES

- A) Appointments, Vacancies and Expiring Terms; review and discussion and/or potential action and/or vote
- 1) Jamestown Harbor Commission (One vacancy with a three-year term ending date of December 31, 2019); duly advertised
 - a) Letter of interest for appointment
 - i) James Heagney

An interview should be scheduled for February 21st prior to the regular meeting.

- 2) Jamestown Tax Assessment Board of Review – Alternate (One vacancy with a one-year term ending date of December 31, 2017); duly advertised; no applicants
- 3) Jamestown Tree Preservation and Protection Committee (Two vacancies with three-year term ending dates of December 31, 2019); duly advertised; no applicants
- 4) Jamestown Community Playground Renovation Committee (Four Citizen-at-large members); duly advertised
 - a) Letters of interest for appointment
 - i) Michelle Bush
 - ii) Michael Cabral
 - iii) Lisa Carlisle
 - iv) Betty Kinder
 - v) Bradley Parsons
 - vi) Christina Smith
 - vii) Barbara Szepatowski

Council members referenced Recreation Director Wade’s memo offering his services for the interview process. The Council would like Mr. Wade to participate in the interview process with them. Interviews will be scheduled for February 21st.

XI. CONSENT AGENDA

An item on the Consent Agenda need not be removed for simple clarification or correction of typographical errors. Approval of the Consent Agenda shall be equivalent to approval of each item as if it had been acted upon separately.

A motion was made by Councilor Dickinson with second by Councilor Meagher to approve and accept the Consent Agenda. President Trocki, Absent; Vice President White, Aye; Councilor Dickinson, Aye; Councilor Meagher, Aye; Councilor Mihaly, Aye.

The Consent Agenda approved consists of the following:

- A) Adoption of Council Minutes

- 1) January 17, 2017 (regular meeting)
- 2) January 17, 2017 (executive session)
- B) Minutes of Boards/Commissions/Committees
 - 1) Jamestown Board of Canvassers (08/23/2016)
 - 2) Jamestown Board of Canvassers (09/13/2016)
 - 3) Jamestown Board of Canvassers (10/18/2016)
 - 4) Jamestown Board of Canvassers (11/18/2016)
 - 5) Jamestown Library Board of Trustees (01/03/2017)
 - 6) Jamestown Library Building Renovation Committee (12/27/2016)
 - 7) Jamestown Library Building Renovation Committee (01/18/2017)
 - 8) Jamestown Traffic Committee (01/19/2017)
 - 9) Jamestown Zoning Board of Review (11/15/2016)
- C) CRMC Notices
 - 1) February 2017 Calendar
- D) Abatements/Addenda of Taxes

Total Abatements: \$44,152.20 Total Addenda: \$49,280.93

 - 1) Real Property/Tangible Abatements to 2016 Tax Roll

	<u>Account/Abatement Amount</u>	
a)	03-0480-05	\$ 1,300.73
b)	04-0575-50	\$ 3,952.60
c)	04-0677-75	\$ 3,776.81
d)	07-0685-00	\$ 6,117.81
e)	13-0097-60	\$ 21.44
f)	13-0214-40	\$ 3,800.35
g)	13-0987-00	\$ 3,350.76
h)	15-0221-01	\$16,599.99
i)	16-0258-00	\$ 5,186.02
j)	19-0962.06	\$ 45.69
 - 2) Real Property/Tangible Addenda to 2016 Tax Roll

	<u>Account/Addenda Amount</u>	
a)	01-0472-21	\$16,599.99
b)	04-0737-00	\$ 6,117.81
c)	06-0276-10	\$ 1,300.73
d)	07-0424-15	\$ 3,800.35
e)	08-0020-00	\$ 3,952.60
f)	08-0518-00	\$ 5,152.96
g)	13-0097-60	\$ 5,228.92
h)	15-0316-00	\$ 3,350.76
i)	19-0270-20	\$ 3,776.81
- E) Finance Director's Report
- F) Private Investigator License Renewal
 - 1) Ronald F. Lewis dba: R. F. Lewis Private Investigators
Address: 139 Seaside Drive
 - 2) Santino Campo, Jr. dba: Santino Campo, Jr.
Address: 9 Lawn Avenue

- G) Trash Collector License Renewals
 - 1) Island Rubbish Service, Inc. dba: Island Rubbish Service, Inc.
Address: 8 Swinburne Street (Island-Wide)
 - 2) Republic Services, Inc. dba: Republic Services of MA
Address: 1080 Airport Road, Fall River, MA 02720 (Island-Wide)
 - 3) Waste Management of RI, Inc. dba: Waste Management of RI, Inc.
Address: 65 Halsey Street, Newport, RI 02840 (Island-Wide)
- H) Holiday License Renewals
 - 1) Baker's Pharmacy of Jamestown, Inc. dba: Baker's Pharmacy
Address: 53 Narragansett Avenue
 - 2) Bay Voyage, LLC dba: Bay Voyage
Address: 150 Conanicus Avenue
 - 3) Gail Chase dba: Hodgkiss Farm
Address: 305 North Road
 - 4) Doriana Carella dba: The Village Hearth Bakery
Address: 2 Watson Avenue
 - 5) Conanicut Yacht Club dba: Conanicut Yacht Club
Address: 40 Bay View Drive
 - 6) East Ferry Market, Ltd. dba: East Ferry Market & Deli
Address: 47 Conanicus Avenue, Units 1 & 2
 - 7) ESJ, Inc. dba: Simpatico Jamestown
Address: 13 Narragansett Avenue
 - 8) Jamestown Boat Yard, Inc. dba: Jamestown Boat Yard
Address: 60 Dumpling Drive
 - 9) Jamestown Culinary Partners, LLC dba: Jamestown Fish
Address: 14 Narragansett Avenue
 - 10) Jamestown Hardware, Inc. dba: Jamestown True Value Hardware
Address: 5 Narragansett Avenue
 - 11) Jamestown Restaurant Group, LLC dba: Narragansett Café
Address: 25 Narragansett Avenue
 - 12) Lucky Ridge Co., LLC dba: Spinnakers Cafe
Location: 3 Ferry Wharf
 - 13) New England Golf Course Management, Inc.
dba: Jamestown Golf & Country Club aka: Caddy Shack
Address: 265 Conanicus Avenue
 - 14) Ocean Essence & Therapeutic Massage, LLC
dba: Ocean Essence & Therapeutic Massage/Ocean Essence Spa
Address: 123B Narragansett Avenue
 - 15) Slice of Heaven, Inc. dba: Slice of Heaven
Address: 32 Narragansett Avenue
 - 16) Tallulah, LLC dba: Tallulah's Tacos
Address: 252 Narragansett Avenue
 - 17) TMT Corp. dba: McQuade's Laundromat
Address: 5 Clarke Street
 - 18) TMT Corp. dba: McQuade's Supermarket

- Address: 6 Clarke Street
- 19) Tunstall, LLC dba: Grapes & Gourmet
Address: 9 Ferry Wharf
- 20) Urban Flowers, LLC dba: The Secret Garden
Address: 12 Southwest Avenue
- 21) Varsha, Inc. dba: Jamestown Wine & Spirits
Address: 30 Southwest Avenue
- I) Holiday and Peddler License Renewal
- 1) A. B. Munroe Dairy, Inc. dba: A. B. Munroe Dairy
Address: 151 North Brow Street, East Providence, RI 02914
(Island-Wide)
- J) One Day Event/Entertainment License Applications
- 1) Applicant: Maggie Burns
Event: Family Party
Date: June 9, 2017
Location: Fort Getty Pavilion
- 2) Applicant: Jessica Roberts
Event: Roberts/Barin Wedding
Date: July 9, 2017
Location: Fort Getty Pavilion
- 3) Applicant: Peter Meegan
Event: Wedding
Date: July 15, 2017
Location: Fort Getty Pavilion
- 4) Applicant: Michael Testa
Event: Family Gathering
Date: July 23, 2017
Location: Fort Getty Pavilion
- 5) Applicant: Paul Schnabel
Event: Schnabel Wedding
Date: August 5, 2017
Location: Fort Getty Pavilion
- 6) Applicant: Paul and Patricia Jutras
Event: Argentine Tango Dance Party
Date: August 6, 2017
Location: Fort Getty Pavilion
- 7) Applicant: Conanicut Yacht Club/Meg Myles
Event: NBYA 420 Junior Sailing Regatta
Date: August 15-16, 2017
Location: Fort Getty Boat Ramp and grass area
- 8) Applicant: Patricia Van Brocklin
Event: Van Brocklin Celebration
Date: August 20, 2017
Location: Fort Getty Pavilion

- 9) Applicant: Barbara Hinkel
Event: Wedding
Date: September 8, 2017
Location: Fort Getty Pavilion
- 10) Applicant: Chad A. Tupper
Event: Wedding
Date: September 15, 2017
Location: Fort Getty Pavilion
- 11) Applicant: Michael Jaswell
Event: Wedding Reception
Date: September 24, 2017
Location: Fort Getty Pavilion
- 12) Applicant: Arnold-Zweir Post 22, American Legion
Events: Memorial Day Parade; activities/events at Veterans Memorial Square
Dates: May 29, July 4, August 14, October 8, November 11, and December 7, 2017; January 15, 2018
Locations: Parade: Lawn Avenue to Veterans Memorial Square; Events: Veterans Memorial Square

Discussion ensued of rental applications for the Fort Getty Pavilion.

XII. COMMUNICATIONS, PETITIONS, AND PROCLAMATIONS AND RESOLUTIONS FROM OTHER RHODE ISLAND CITIES AND TOWNS

A motion was made by Councilor Dickinson with second by Councilor Meagher to accept the Communications. President Trocki, Absent; Vice President White, Aye; Councilor Dickinson, Aye; Councilor Meagher, Aye; Councilor Mihaly, Aye.

The Communications accepted consists of the following:

- A) Communications
 - 1) Letter of Quonset Development Corporation Finance Director Kevin Barry with 2016 Annual Report
 - 2) Letter of Taxpayers' Association of Jamestown Executive Board requesting a Fire Department Renovation Project financial report as an agenda item during the March budget sessions

- B) Proclamations and Resolutions from other Rhode Island Cities and Towns
 - 1) Resolution of the Charlestown Town Council in Opposition to the Preferred Route by the Federal Railroad Administration
 - 2) Resolution of the Warwick City Council Requesting the General Assembly enact Legislation to classify Multi-Unit Rental Housing as Non-Smoking

Councilor Mihaly commented Resolution 1) is very important. Solicitor Ruggiero explained the opposition to the Kenyon Bypass, relocating the railroad tracks through

Richmond, Charlestown, and Westerly.

A motion was made by Councilor Meagher with second by Councilor Mihaly to support the Resolution. President Trocki, Absent; Vice President White, Aye; Councilor Dickinson, Aye; Councilor Meagher, Aye; Councilor Mihaly, Aye.

A motion was made by Councilor Meagher with second by Councilor Dickinson to accept the Resolutions and Proclamations. President Trocki, Absent; Vice President White, Aye; Councilor Dickinson, Aye; Councilor Meagher, Aye; Councilor Mihaly, Aye.

XIII. AGENDA ITEMS FOR THE NEXT MEETING AND FUTURE MEETINGS

- A) Request for Enabling Legislation for Charter Amendments adopted by the voters at the November 8, 2016 General Election

XIV. EXECUTIVE SESSION

The Town Council may seek to go into Executive Session to discuss the following items:

- A) Pursuant to RIGL §42-46-5(a) Subsection (2) Collective Bargaining (IBPO contract negotiations); review and discussion and/or potential action and/or vote in executive session and/or open session

A motion was made by Councilor Meagher with second by Councilor Dickinson to enter into Executive Session pursuant to RIGL 42-46-5(a) Subsection (2) Collective Bargaining at 9:37 p.m.

Pursuant to RIGL §42-46-5(a) Subsection (2) Collective Bargaining, the following vote was taken: President Trocki, Absent; Vice President White, Aye; Councilor Dickinson, Aye; Councilor Meagher, Aye; Councilor Mihaly, Aye.

The Town Council reconvened the regular meeting at 10:10 p.m. Vice President White announced that no votes were taken in Executive Session.

A motion was made by Councilor Meagher with second by Councilor Dickinson to seal the Minutes of the Executive Session. President Trocki, Absent; Vice President White, Aye; Councilor Dickinson, Aye; Councilor Meagher, Aye; Councilor Mihaly, Aye.

XIV. ADJOURNMENT

A motion was made by Councilor Meagher with second by Councilor Dickinson to adjourn. President Trocki, Absent; Vice President White, Aye; Councilor Dickinson, Aye; Councilor Meagher, Aye; Councilor Mihaly, Aye.

The Jamestown Town Council adjourned the regular meeting at 10:11 p.m.

Attest:

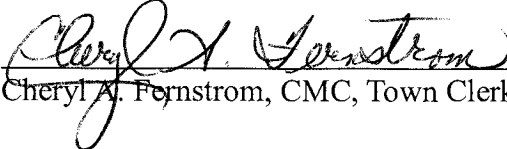
Cheryl A. Fernstrom, CMC, Town Clerk

Copies to: Town Council
 Town Administrator
 Finance Director
 Town Solicitor



Jamestown Harbor Office
250 Conanicus Avenue
Jamestown, RI 02835
401-423-7190

**TOWN OF JAMESTOWN
HARBOR COMMISSION**

Minutes of the January 11, 2017 Meeting of the Jamestown Harbor Commission
Amended: 2/8/2017 Approved: 2/8/2017

A meeting of the Jamestown Harbor Commission (JHC) was held Wednesday, January 11, 2017 at the Jamestown Town Hall, 93 Narragansett Avenue, Jamestown, Rhode Island.

I. CALL TO ORDER AND ROLL CALL

Chairman Cain called the meeting to order at 7:00 PM with roll call:

Present:

David Cain, Chairman
Wayne Banks, Commissioner
Dan Wurzbacher, Commissioner
Joseph McGrady, Commissioner
Clifford Kurz, Commissioner

Absent:

William Harsch, Vice-Chairman

Also in attendance:

Chief Edward Mello, Executive Director
Mark Campbell, Harbormaster
Kim Devlin, Harbor Clerk
George Souza, Conservation Commission Liaison

II. APPROVAL OF MEETING MINUTES

A. Wednesday, December 14, 2016

Commissioner Wurzbacher moved to accept the minutes of the Wednesday December 14, 2016 Jamestown Harbor Commission meeting, Commissioner McGrady seconded. So voted; (5 ayes, 0 nays).

III. OPEN FORUM

A. Scheduled Requests to Address

No Scheduled requests to address.

B. Non-scheduled Requests to Address

No Non-scheduled requests to address.

IV. EXECUTIVE DIRECTOR MELLO'S REPORT

Executive Director Chief Mello reported the Online Mooring web service provider increased their fees from \$5 to \$6.

Executive Director Chief Mello reported that he met with Commissioner Kurz and he will present the budget, 2017 rates and long range infrastructure plan at the next town council meeting.

V. HARBORMASTER REPORT

Harbormaster Campbell had no update.

VI. MARINE DEVELOPMENT FUND BUDGET

A. 2015/2016 MDF YTD Budget

The Marine Development Fund budget was not available.

VII. SUB-COMMITTEE REPORTS

A. Budget

Commissioner Kurz ~~was absent~~ had nothing to report.

B. Facilities

Chairman Cain stated that this position is vacant and asked Commissioners Wurzbacher and Banks if they would be interested in taking over.

Executive Director Chief Mello stated it is a pretty active role consisting of meeting with town staff on site to discuss projects and repairs and working with the Chief, Harbormaster and Public Works Department to maintain the Harbor facilities. Executive Director Chief Mello suggested that there could even be a three person sub-committee.

Commissioner Banks and Wurzbacher both stated that they would consider the role.

C. Mooring Implementation

Chairman Cain had nothing to report.

D. Traffic Committee

Chairman Cain had nothing to report.

VIII. LIAISON REPORTS

A. Conservation Commission Liaison

Conservation Commission Liaison Souza had nothing to report.

Chairman Cain requested Conservation Commission Liaison Souza keep the Jamestown Harbor Commission apprised of things that the Conservation Commission has on their docket.

IX. OLD BUSINESS

There was no Old Business to discuss.

X. CORRESPONDENCE

A. Memo from the Jamestown Conservation Commission – Re: Rights of Way; 12/13/2016

XI. NEW BUSINESS

A. West Ferry Outhaul Repairs

Executive Director Chief Mello reported that there are no alternative options to repairing the West Ferry outhaul pilings, as Commissioner Dickinson suggested at the last meeting. The pilings cannot be driven from land and we are looking for a way to avoid the coring, but it looks like there are no other options. Public Works Director, Mike Gray, will be presenting his recommendation to the Town Council on Tuesday.

XII. OPEN FORUM – CONTINUED

Commissioner Banks stated there is a sign at the Ft. Getty boat ramp that states there is no kayak launching from the boat ramp and that is a hardship for some people.

Executive Director Chief Mello stated he would look into how the sign was placed there, but that it was not the Harbor Department that installed the sign.

Harbormaster Campbell stated that there have been conflicts between people trying to launch boats from the ramp and kayakers.

XIII. ADJOURNMENT

Commissioner McGrady moved to adjourn at 7:14 PM, seconded. So voted; (5 ayes, 0 nays).

Respectfully submitted,



Kim Devlin
Jamestown Harbor Clerk



State of Rhode Island and Providence Plantations
Coastal Resources Management Council
 Oliver H. Stedman Government Center
 4808 Tower Hill Road, Suite 3
 Wakefield, RI 02879-1900

(401) 783-3370
 Fax (401) 783-2069

PUBLIC NOTICE

File Number: 2016-12-052 Date: February 8, 2017

This office has under consideration the application of:

**602 East Shore Road Trust
 c/o Steve Tilley
 117 Mourning Dove Drive
 Saunderstown, RI 02842**

for a State of Rhode Island Assent to construct and maintain: a fixed timber pier with a fixed terminus and 1200-lb tender lift extending 116-feet beyond Mean Low Water (MLW). The facility is designed to span eelgrass. It will be a "touch & go" facility. No variances are required.

Project Location:	602 East Shore Road
City/Town:	Jamestown
Plat/Lot:	2 / 83
Waterway:	East Passage of Narragansett Bay

Plans of the proposed work may be seen at the CRMC office in Wakefield.

In accordance with the Administrative Procedures Act (Chapter 42-35 of the Rhode Island General Laws) you may request a hearing on this matter.

You are advised that if you have good reason to enter protests against the proposed work it is your privilege to do so. It is expected that objectors will review the application and plans thoroughly, visit site of proposed work if necessary, to familiarize themselves with the conditions and cite what law or laws, if any, would in their opinion be violated by the work proposed.

If you desire to protest, you must attend the scheduled hearing and give sworn testimony. A notice of the time and place of such hearing will be furnished you as soon as possible after receipt of your request for hearing. If you desire to request a hearing, to receive consideration, it should be in writing (**with your correct mailing address, e-mail address and valid contact number**) and be received at this office on or before March 8, 2017.

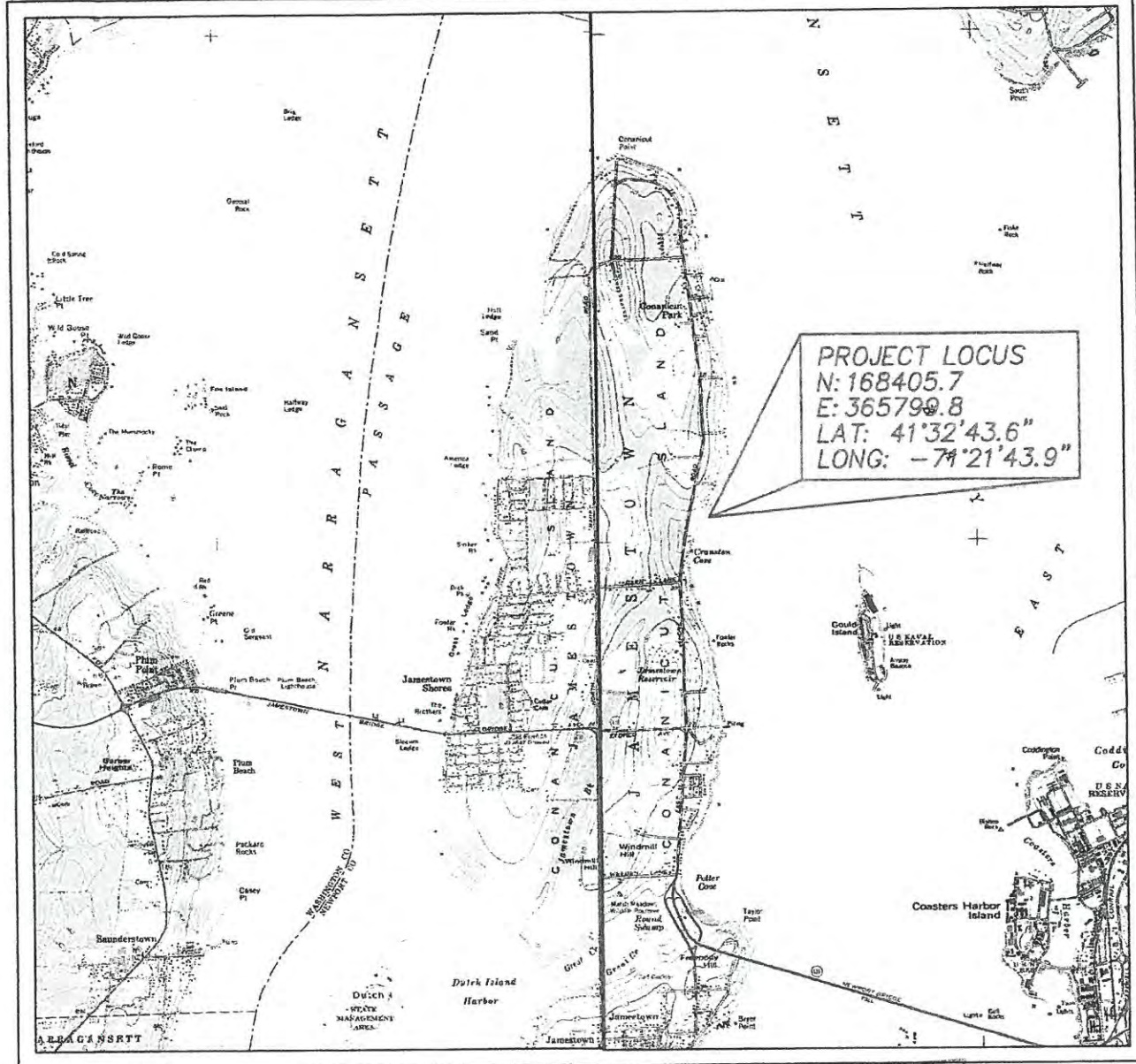

PROJECT LOCUS
 N: 168405.7
 E: 365799.8
 LAT: 41°32'43.6"
 LONG: -71°21'43.9"

LOCUS PLAN
 1" = 1 MILE

RECEIVED
 DEC 27 2016
 COASTAL RESOURCES
 MUNICIPAL ENGINEER

PROPOSED RESIDENTIAL PIER AND BOATLIFT FOR:
 602 EAST SHORE ROAD TRUST
 602 EAST SHORE ROAD
 AP 2, LOT 83
 JAMESTOWN, RI 02835
 BY: WARREN HALL, CIVIL ENGINEER
 12-13-16 SHEET 1 OF 7

WARREN F HALL

 REGISTERED
 PROFESSIONAL ENGINEER

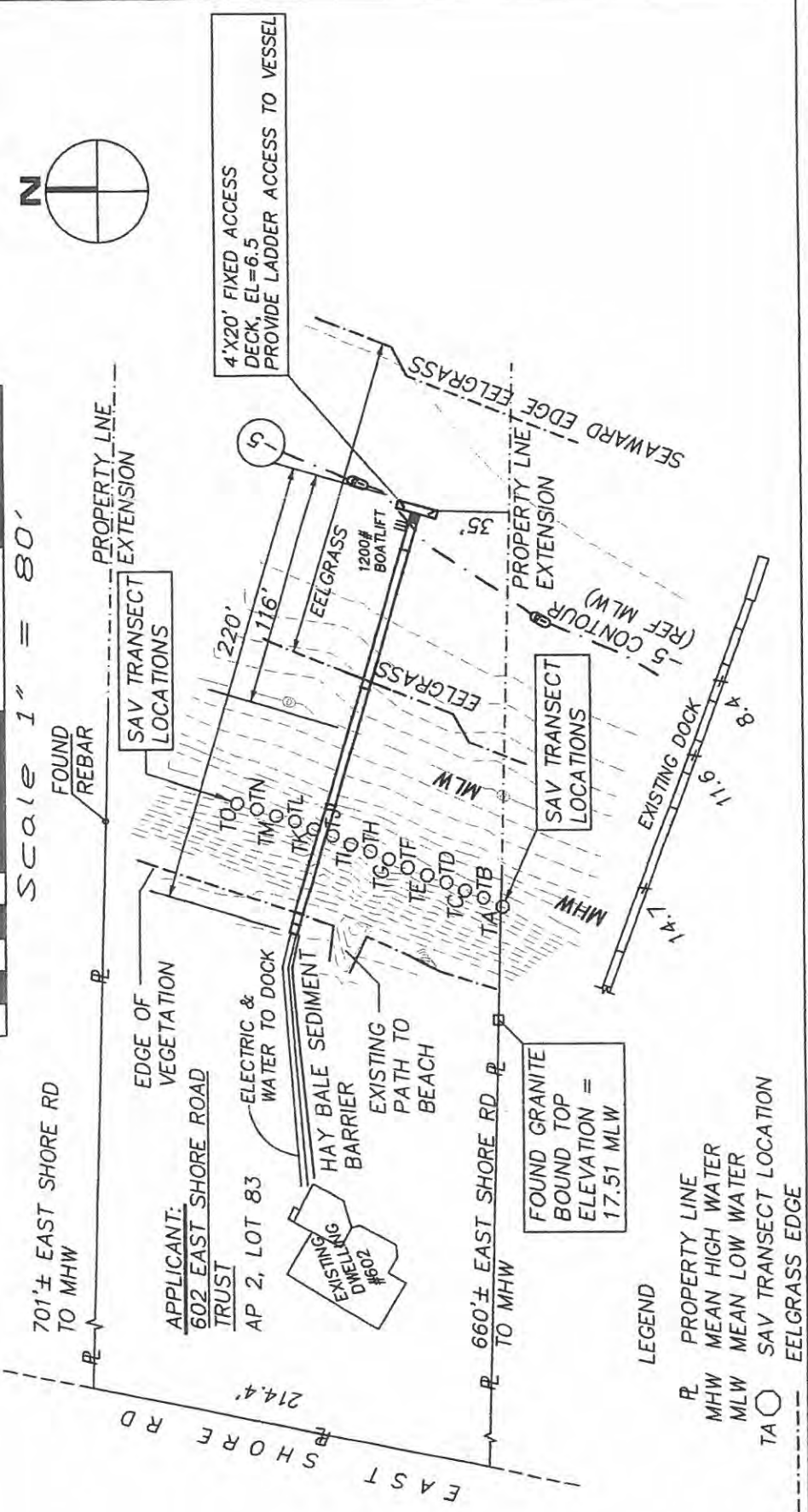
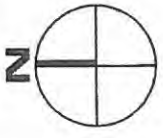

- LEGEND
- ▬ PROPERTY LINE
 - ▬ MHW MEAN HIGH WATER
 - ▬ MLW MEAN LOW WATER
 - SAV TRANSECT LOCATION
 - - - EELGRASS EDGE

PROPOSED RESIDENTIAL PIER AND BOATLIFT FOR:
 602 EAST SHORE ROAD TRUST
 602 EAST SHORE ROAD
 AP 2, LOT 83
 JAMESTOWN, RI 02835
 BY: WARREN HALL, CIVIL ENGINEER
 12-13-16 1"=80' SHEET 2 OF 7

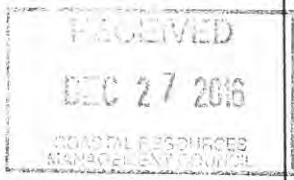



BURDICK & SHORT:
 3.08M + 2(6.35)M = 4.35M (14.3')

4'X20' FIXED ACCESS
 DECK, EL=6.5
 PROVIDE LADDER ACCESS TO VESSEL

N: 168405.7
 E: 365799.8

N: 168331.5
 E: 365598.8

N: 168350.6
 E: 365592.8

1200# CAPACITY
 BOATLIFT

5 @ 11'

EEL GRASS

PIER DIRECTION
 S73°-32'E

MHW
 DECK EL=12.4

DECK EL=12.4

DECK EL=10.0

MHW 3.52
 MLW 0.0

BATTER PILE
 SEE SHEET 7

ELECTRIC &
 WATER TO DOCK

DECK EL=17.3

MHW
 DECK EL=12.4

DECK EL=12.4

14.5'

-2.1

-0.1

2.2

5.3

12.1

16.6

-4.5

-3.7

-4.9

-5.3

EXISTING GRADE

1+00

1+50

1+00

0+50

0+00

2+00

WARREN F HALL

REGISTERED PROFESSIONAL ENGINEER

RECEIVED
 DEC 27 2016
 CONSULTING RESOURCES
 100 WASHINGTON STREET
 PROVIDENCE, RI 02902

PROPOSED RESIDENTIAL PIER AND BOATLIFT FOR:
 602 EAST SHORE ROAD TRUST
 602 EAST SHORE ROAD
 AP 2, LOT 83
 JAMESTOWN, RI 02835
 BY: WARREN HALL, CIVIL ENGINEER
 12-13-16 1"=30' SHEET 3 OF 7

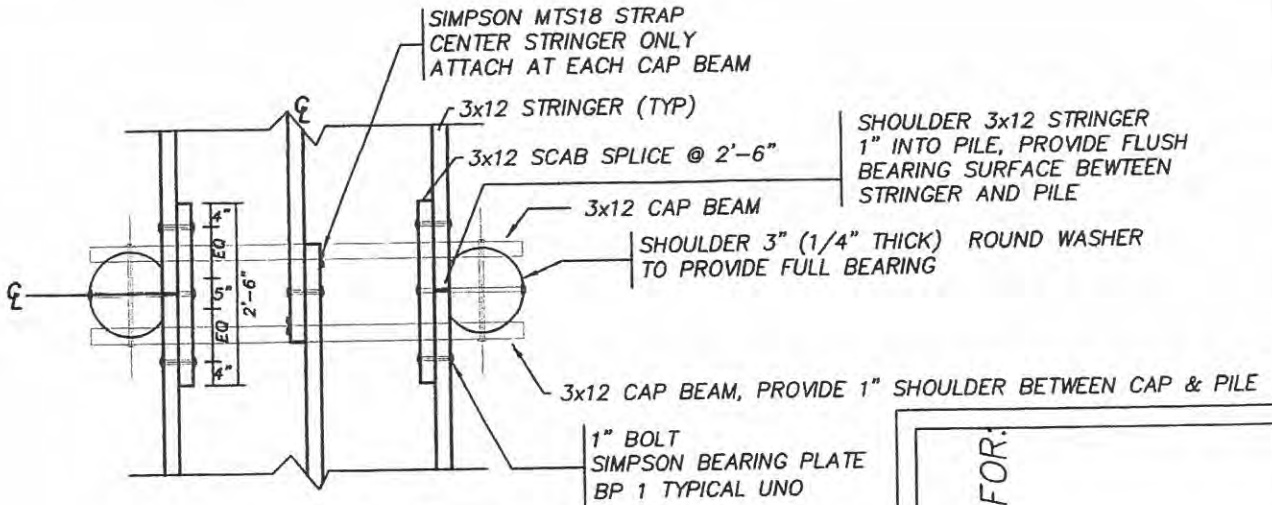

PLAN VIEW PILE BENT FRAMING
3/8"=1'-0"

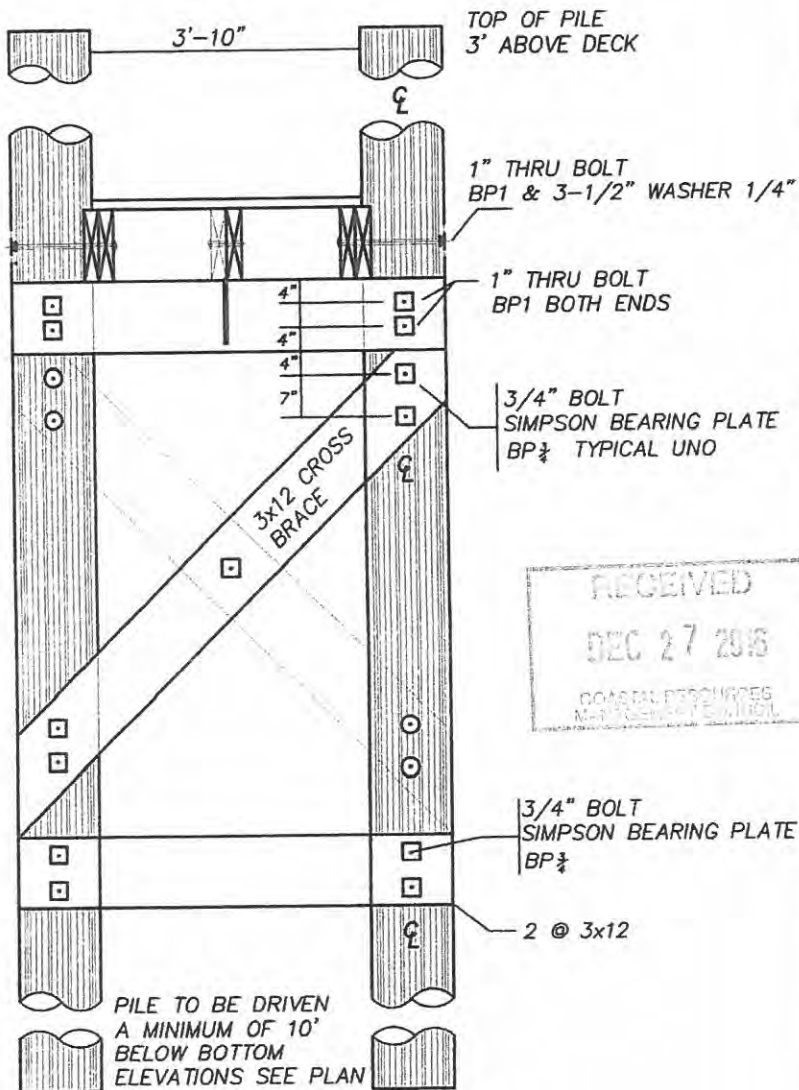

TRANSVERSE SECTION PILE BENT
3/8"=1'-0"

PROPOSED RESIDENTIAL PIER AND BOATLIFT FOR:
602 EAST SHORE ROAD TRUST
602 EAST SHORE ROAD
AP 2, LOT 83
JAMESTOWN, RI 02835
BY: WARREN HALL, CIVIL ENGINEER
SHEET 4 OF 7
12-13-16

RECEIVED
DEC 27 2016
COASTAL RESOURCES
MANAGEMENT CENTER

WARREN F HALL

REGISTERED
PROFESSIONAL ENGINEER

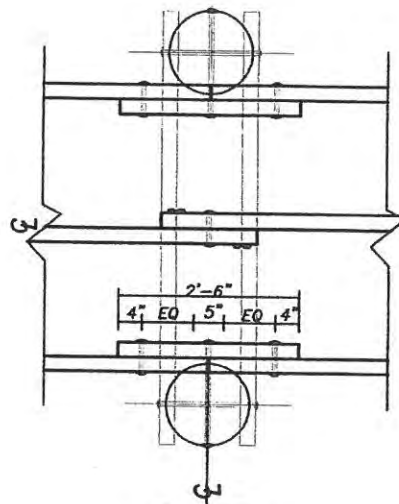

FRAMING PROPERTIES:
 SOUTHERN YELLOW PINE
 Fb 1200 PSI
 Fv 80 PSI
 DECK PLANKS TO BE 3x8 #1 GRADE

NOTES:
 1) ALL BOLT HOLES SHALL BE PRE DRILLED 1/16" GREATER THAN DIAMETER OF BOLT
 2) ALL BOLTS SHALL BE HDG ASTM A307 GRADE A WITH HEAVY HEX NUTS

LEGEND
 SS: STAINLESS STEEL
 HDG: HOT DIPPED GALVANIZED

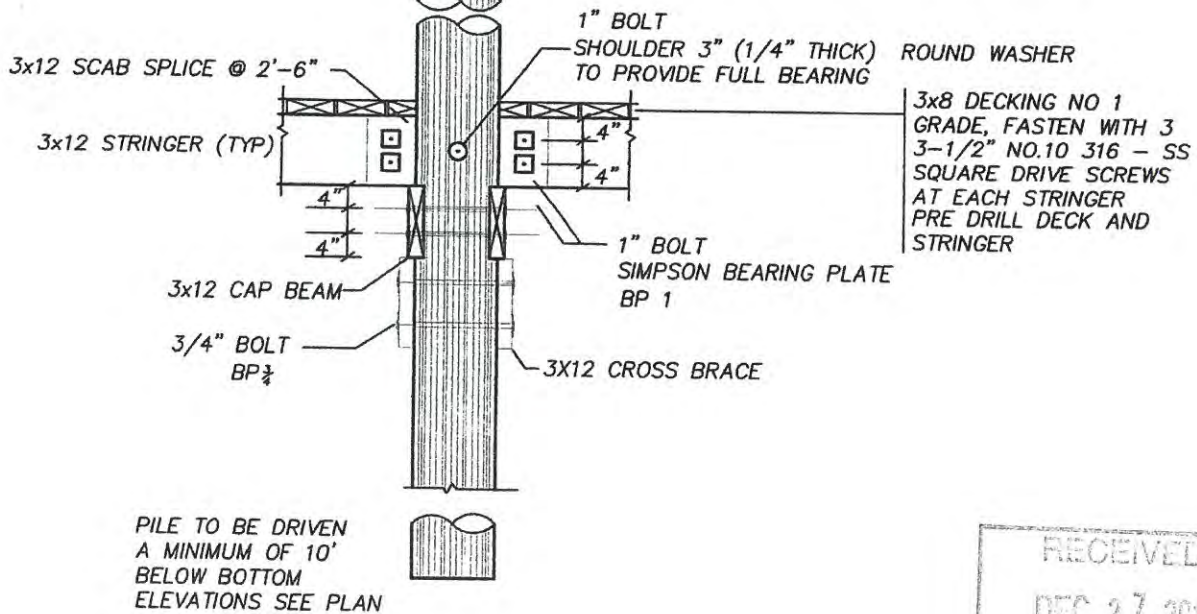

PILE TO BE DRIVEN
 A MINIMUM OF 10'
 BELOW BOTTOM
 ELEVATIONS SEE PLAN

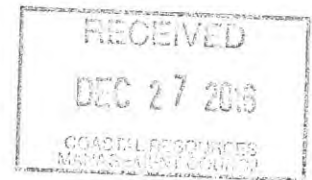

LONGITUDINAL SECTION PILE BENT
 3/8"=1'-0"

PROPOSED RESIDENTIAL PIER AND BOATLIFT FOR:
 602 EAST SHORE ROAD TRUST
 602 EAST SHORE ROAD
 AP 2, LOT 83
 JAMESTOWN, RI 02835
 BY: WARREN HALL, CIVIL ENGINEER
 12-13-16 SHEET 5 OF 7

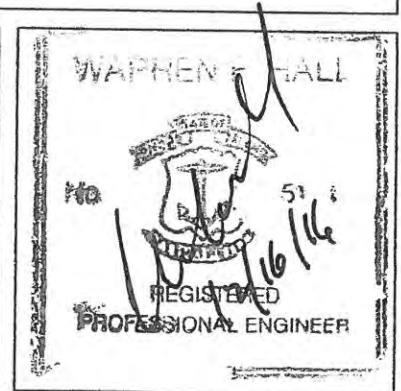

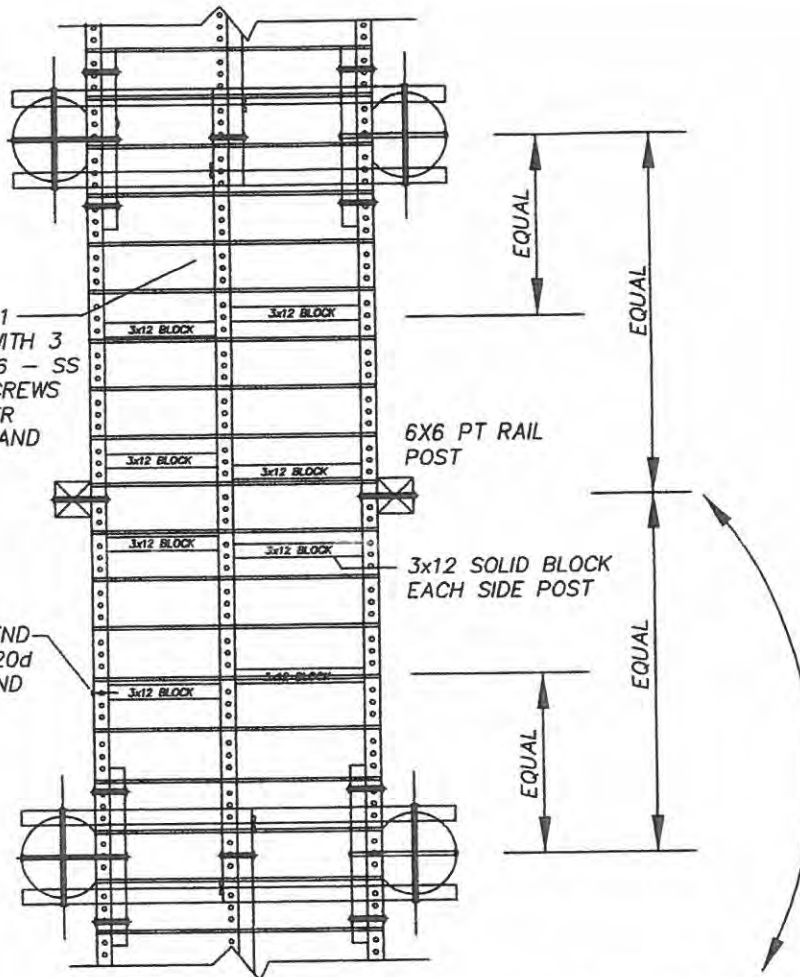

3x8 DECKING NO 1
GRADE, FASTEN WITH 3
3-1/2" NO.10 316 - SS
SQUARE DRIVE SCREWS
AT EACH STRINGER
PRE DRILL DECK AND
STRINGER

6X6 PT RAIL
POST

3x12 SOLID BLOCK
EACH SIDE POST

3x12 BLOCK END
NAIL WITH 3 20d
HDG AT EA END

4' (DECKING)

PLAN VIEW TYPICAL FRAMING
3/8"=1'-0"

RECEIVED
DEC 27 2016
COASTAL RESOURCES
MANAGEMENT SOLUTION

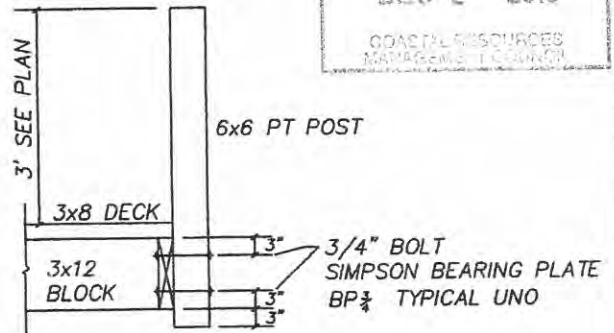

DETAIL AT RAILING POST
3/8"=1'-0"

PROPOSED RESIDENTIAL PIER AND BOATLIFT FOR:
602 EAST SHORE ROAD TRUST
602 EAST SHORE ROAD
AP 2, LOT 83
JAMESTOWN, RI 02835
BY: WARREN HALL, CIVIL ENGINEER
12-13-16 SHEET 6 OF 7

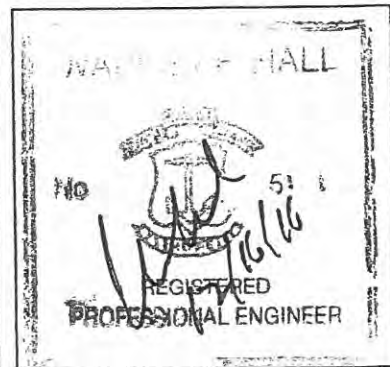

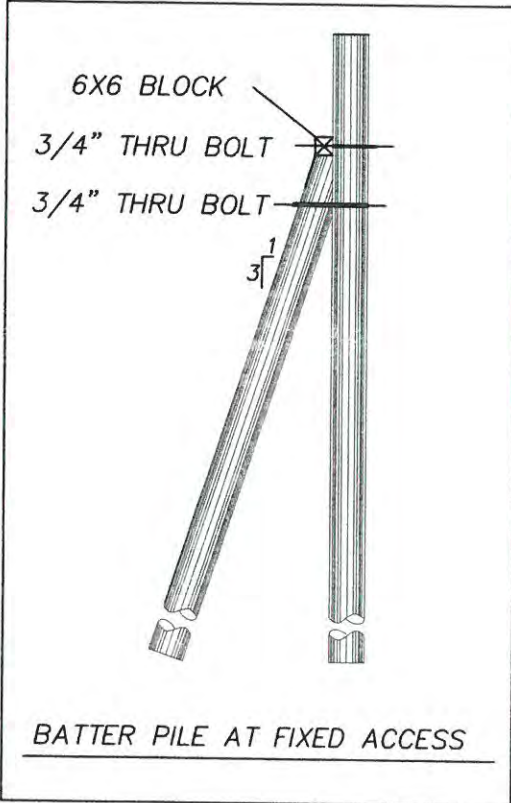
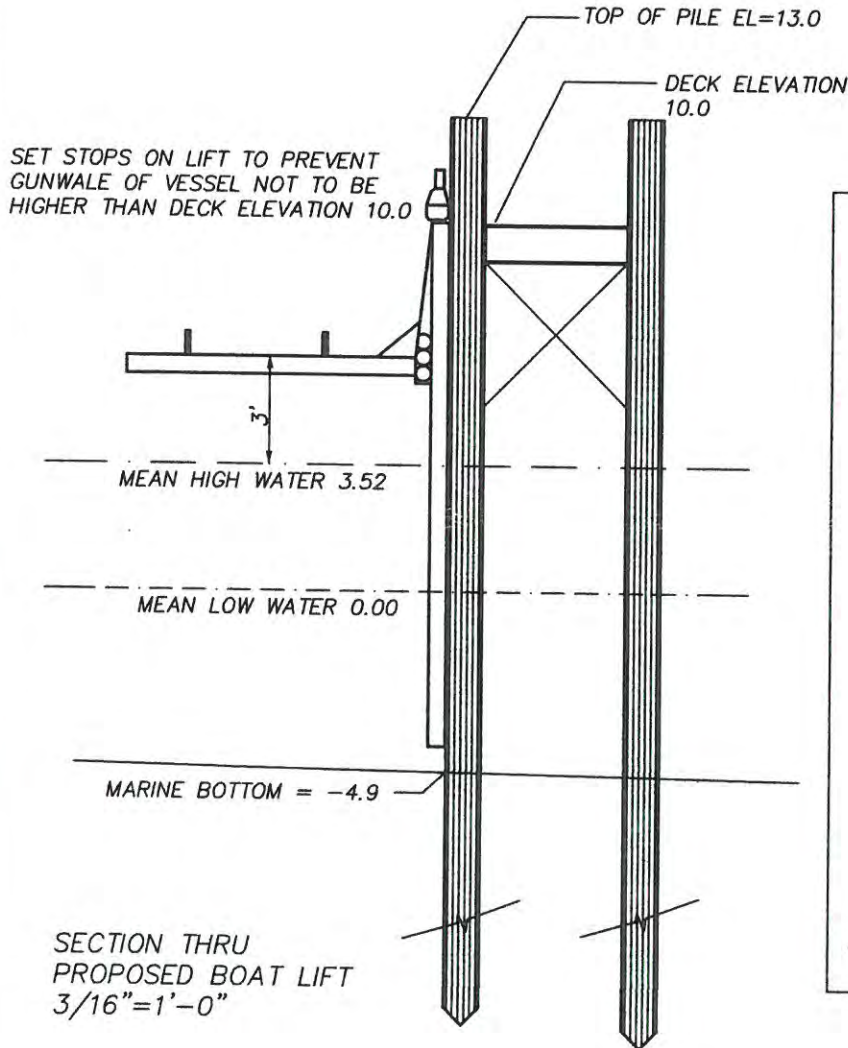

GENERAL NOTES ON BOAT LIFT

- 1) FACILITY SHALL BE LIMITED TO TOUCH "N" GO OPERATION ONLY.
- 2) A MOORING IS PROVIDED AND IS AVAILABLE FOR LONG TERM DOCKING.
- 3) BOATLIFT RESTRICTED TO VESSELS 12' OR LESS IN LENGTH & 1200 POUNDS OR LESS IN WEIGHT

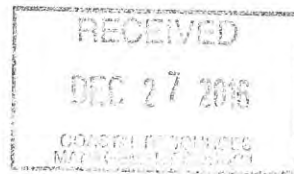

PROPOSED RESIDENTIAL PIER AND BOATLIFT FOR:
602 EAST SHORE ROAD TRUST
602 EAST SHORE ROAD
AP 2, LOT 83
JAMESTOWN, RI 02835
BY: WARREN HALL, CIVIL ENGINEER
12-24-16 3/16"=1'-0" SHEET 7 OF 7

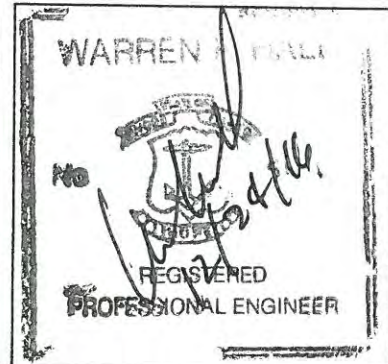



Oliver Stedman Government Center
4808 Tower Hill Road, Suite 116
Wakefield, RI 02879
401-783-3370

**PUBLIC NOTICE for PROPOSED RULE-MAKING and
PUBLIC HEARING**

**Proposed Amendments to the Coastal Resources Management Program
Management Procedures**

Pursuant to Chapter 46-23 of the State of Rhode Island General Laws, as amended, the Coastal Resources Management Council (CRMC) proposes to amend and take public comment on the following proposed amendments only of the Coastal Resources Management Program (CRMP): **Management Procedures**. Comments will not be taken on any other section of the Coastal Resources Management Program during this notice period. In accordance with the procedures of the RI Administrative Procedures Act (R.I.G.L. § 42-35) and the Rules and Regulations of the Coastal Resources Management Council, notice is hereby given of the intent of the Coastal Resources Management Council to hold a public hearing, accept public comment, and afford interested persons reasonable opportunity to submit data, views or arguments orally or in writing during the 30-day comment period and the public hearing.

The **public hearing** will be held at **6:00 p.m. on Tuesday, March 28, 2017 in Conference Room A at the Department of Administration, One Capitol Hill, Providence, RI**. The room is accessible to the disabled and persons requesting interpreter services for the hearing impaired must notify the Council office at 401-783-3370 or RI 711 at least three (3) business days in advance of the hearing date so that such assistance can be provided at no cost to the person requesting.

Summary of Proposed Amendment to Management Procedures.:

The purpose of the proposed regulation change is to reformat CRMC Management Procedures into the RI Code of Regulations (RICR) specified format and eliminate some existing text and notations, and codify some existing notations in conformance with the RICR and the Administrative Procedures Act R.I.G.L. § 42-35.

The Council has complied with the requirements of R.I. General Laws §§ 42-35.1-3 and 42-35.1-4 and has filed copies of the proposed regulations with the Governors Office and the Office of Regulatory Reform of the Department of Administration's Office of Management and Budget. The Council has determined that the proposed regulations do not overlap or duplicate any other state regulation and will not have any adverse effect on small businesses.

The proposed regulations are available on the CRMC website – www.crmc.ri.gov. Additionally, the proposed regulations can be reviewed in person at the Coastal Resources Management Council offices located at the Oliver Stedman Government Center, 4808 Tower Hill Road, Wakefield, RI. Further information may be obtained by contacting the Coastal Resources Management Council offices at 783-3370.

All interested persons are invited to submit written comments on the proposed amendments to the **CRMC Management Procedures** by **March 10, 2017** to provide advance notice to the Council prior to the public hearing. All such comments should be directed to Grover J. Fugate, Executive Director, at the above address.

Signed this 6th day of February, 2017

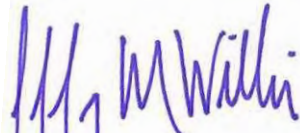

Jeffrey M. Willis, Deputy Director
Coastal Resources Management Council

Proposed Amendment

RI Coastal Resources Management Program – Management Procedures

The Management Procedures have been reformatted and some text edited as shown below in accordance with the RI Code of Regulations specified format to comply with the Administrative Procedures Act R.I.G.L. § 42-35

New text is underlined; deleted text is ~~struck through~~



**Town of Jamestown
Tax Assessor**

**93 Narragansett Avenue
Jamestown, RI 02835**

**Phone: 401-423-9802
Email: kgray@jamestownri.net**

To: PRESIDENT, JAMESTOWN TOWN COUNCIL

From: JAMESTOWN TAX ASSESSOR

Subject: ABATEMENTS/ADDENDA OF TAXES FOR THE **FEBRUARY 21, 2017** MEETING

REAL PROPERTY/TANGIBLE ABATEMENTS TO 2016 TAX ROLL

#02-0509-94 Bennett, Katherine & Weaver, Louise	Plat 2, Lot 40 – Property Transfer 1-13-17 to Account #19-0576-00	\$2,163.88
#03-1694-00 Curran Family Partnership	Plat 10, Lot 31 – Property Transfer 1-6-17 to Account #04-0863-10	\$15,220.33
#06-0115-50 Fazio, George J. & Susan E., Trustees	Plat 8, Lot 887 – Property Transfer 1-5-17 to Account #26-0053-75	\$3,600.26
#11-0119-00 Keen, Martin W. & Mary H.	Plat 4, Lot 24 – Property Transfer 1-10-17 to Account #19-1224-01	\$4,319.44
#12-0236-01 Laurie Family Trust	Plat 11, Lot 2 – Property Transfer 1-13-17 to Account #20-0587-05	\$22,943.19
#12-0925-00 Lukowicz, Loretta P.	Plat 3, Lot 196 – Property Transfer 1-26-17 to Account #06-0168-57	\$1,900.74
#13-1955-50 Moore, Lynn M.	Plat 14, Lot 282 – Property Transfer 1-9-17 to Account #03-0131-10	\$103.82
#18-0176-00 Rembijas, Richard J. & Elena V.	Plat 9, Lot 612 – Adjustment to property record First floor unfinished - Assessment to \$371,200	\$564.56
#18-0222-00 Renaud, Michael T. & Megan E.	Plat 8, Lot 252 – Tax Board Appeal – Reduced Garage value - Assessment lowered to \$801,500	\$772.20
#18-0347-15 Richard, Michael F. (Estate)	Plat 5, Lot 77 – Property Transfer 1-9-17 to Account #19-1487-00	\$3,216.91
#18-0640-00 Rockwood Lane Realty, LLC	Plat 2, Lot 69 – Property Transfer 1-12-17 to Account #04-0231-05	\$34,667.76
#18-0742-10 Rosenberg, Jerrold N.	Plat 10, Lot 1 – Property Transfer 1-17-17 to Account #13-1628-25	\$17,542.93
#18-0817-25 Rozes, James S. & Maureen A.	Plat 9, Lot 344 – Property Transfer 1-5-17 to Account #20-0544-20	\$2,402.11
#20-0544-20 Trinque, Brian & Anne	Plat 9, Lot 344 – Portion of previous owner’s Veteran exemption	\$10.47
#23-0080-00 Waldman, Margot & Haspiel, Elizabeth	Plat 9, Lot 267 – Tax Board Appeal – Reduced Grade & Depr. - Assessment lowered to \$797,700	\$1,113.68
#23-0942-00 Williams, Dennis K. & T. Roseann	Plat 10, Lot 55 – Property Transfer 1-23-17 to Account #23-0110-50	\$14,469.31
#23-0942-00 Williams, Dennis K. & T. Roseann	Plat 10, Lots 53&54–Property Transfer 1-23-17 to Account #03-1112-00	\$35,302.67

#23-1073-30 Woods, Darryl & Valerie L.	Plat 15, Lot 102 – Property Transfer 1-20-17 to Account #18-0875-01	\$2,594.00
---	--	------------

REAL PROPERTY/TANGIBLE ADDENDA TO 2016 TAX ROLL

#03-0131-10 Campot, Kevin R. & Marcie	Plat 14, Lot 282 – Property Transfer 1-9-17 from Account #13-1955-50	\$103.82
#03-1112-00 Collingsworth Breck&Tracy Family LLC	Plat 10 Lots 53&54–Property Trans. 1-23-17 from Account #23-0942-00	\$35,302.67
#04-0231-05 Davitt, Matthew Owen	Plat 2, Lot 69 – Property Transfer 1-12-17 from Account #18-0640-00	\$34,667.76
#04-0863-10 Driscoll, Keith L. et al	Plat 10, Lot 31 – Property Transfer 1-6-17 from Account #03-1694-00	\$15,220.33
#06-0168-57 Ferri, Thomas J. & Paula J.	Plat 3, Lot 196 – Property Transfer 1-26-17 from Account #12-0925-00	\$1,900.74
#13-1628-25 Milne, Simon S. & Julia I.	Plat 10, Lot 1 – Property Transfer 1-17-17 from Account #18-0742-10	\$17,542.93
#18-0875-01 Ryan, Mark	Plat 15, Lot 102 – Property Transfer 1-20-17 from Account #23-1073-30	\$2,594.00
#19-0576-00 Shafts, Robert & Catherine	Plat 2, Lot 40 – Property Transfer 1-13-17 from Account #02-0509-94	\$2,163.88
#19-1224-01 Snoeren, Pieter	Plat 4, Lot 24 – Property Transfer 1-10-17 from Account #11-0119-01	\$4,319.44
#19-1487-00 Stitt, Janet A. & Michael J.	Plat 5, Lot 77 – Property Transfer 1-9-17 from Account #18-0347-15	\$3,216.91
#20-0544-20 Trinque, Brian & Anne	Plat 9, Lot 344 – Property Transfer 1-5-17 from Account #18-0817-25	\$2,402.11
#20-0587-05 Tsocanos, Mark A. & Kimberly E.	Plat 11, Lot 2 – Property Transfer 1-13-17 from Account #12-0236-01	\$22,943.19
#23-0110-50 Walnut Grove, LLC	Plat 10, Lot 55 – Property Transfer 1-23-17 from Account #23-0942-00	\$14,469.31
\$26-0053-75 Zona, Anthony A. Jr., Trustee	Plat 8, Lot 887 – Property Transfer 1-5-17 from Account #06-0115-50	\$3,600.26

TOTAL ABATEMENTS	\$162,908.26
TOTAL ADDENDA	\$160,447.35

RESPECTFULLY SUBMITTED,

Kenneth S. Gray

KENNETH S. GRAY,
TAX ASSESSOR

Called 1/24
Spoke w/ Kim

New Mailing Address
Cumberland Farms, Inc.
Tax Department
165 Flanders Road
Westborough, MA 01581

TOWN OF JAMESTOWN

Town Clerk's Office
93 Narragansett Avenue
Jamestown, RI 02835
423-7200 ~ Fax: 423-7230

RECEIVED
TOWN OF JAMESTOWN, R.I.
17 JAN 23 AM 10:12

Holiday License Renewal Application

Please provide the following:

- Application Fee: \$20.00
- Retail Sales Tax Permit
- Department of Health Certificate

License Holder:

Permit for the Period of: March 1, 2017 to February 28, 2018

Corporate Name: Cumberland Farms, Inc.

Doing Business As: (dba) Cumberland Farms Store #1108

Location of Business: 41 North Road

Business Phone: 423-2507 RI Retail Tax ID #: 101786123

Hours of Operation: 5 am to Midnight

Business Address/Mailing Address & Phone Number (if different from above):
165 Flanders Rd. Westborough Ma 01581
100 Crossing Blvd. Framingham, MA 01702 508-270-1400

Partnerships & Corporations: Please list names, addresses & dates of birth for all partners and principal officers/stockholders:

<u>Name</u>	<u>Address</u>	<u>Date of Birth</u>
<u>Please Attach List</u>		

Type of Operation: (restaurant, bakery, gift shop, etc.)

Convenience Store

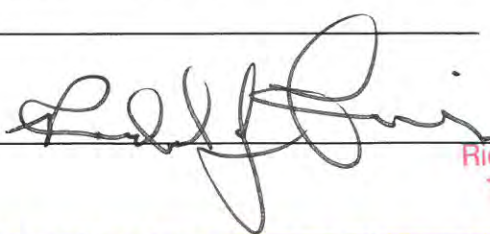
Signature of Applicant:  Richard Fournier
Tax Manager

All Tax & Water Assessments must be paid to date prior to any known Town Council Action.

Your application will not be acted upon should payment of these be in arrears.

For Office Use Only

Application Fee: \$20.00 ✓

Paid/Date: January 23 2017

Approval: Please Sign & Date

Chief of Police:  1-25-17

Fire Chief:  1-24-17

Zoning Official:  1-23-17

Water & Sewer Clerk:  2/6/17

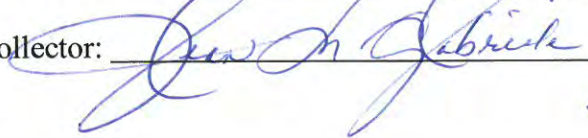
Tax Collector:  1/24/17



This application has been **GRANTED/DENIED** by the Jamestown Town Council at a meeting held on the _____ day of _____, 2017 for the period of **March 1, 2017 to February 28, 2018.**

Issued: _____

Cheryl A. Fernstrom, CMC, Town Clerk

TOWN OF JAMESTOWN

Town Clerk's Office
93 Narragansett Avenue
Jamestown, RI 02835
423-7200 ~ Fax: 423-7230

1/24
Spoken/Chuckle
Chopmist
MAY-OWNER
W/ST/Meeting

Holiday License Renewal Application

Please provide the following:

- Application Fee: \$20.00 Retail Sales Tax Permit
 Department of Health Certificate

License Holder:

Permit for the Period of: March 1, 2017 to February 28, 2018

Corporate Name: Islandish, Ltd.

Doing Business As: (dba) Chopmist Charlies

Location of Business: 40 Narragansett Avenue

Business Phone: 423-1020 RI Retail Tax ID #: 050481124

Hours of Operation: 11:30 am to 1:00 am by RIGL

Business Address/Mailing Address & Phone Number (if different from above):

Same as above 742-1980

Partnerships & Corporations: Please list names, addresses & dates of birth for all partners and principal officers/stockholders:

<u>Name</u>	<u>Address</u>	<u>Date of Birth</u>
-------------	----------------	----------------------

<u>Charles T. Masso</u>	<u>15 Weeden Ln. Jamestown</u>	<u>11/24/1956</u>
-------------------------	--------------------------------	-------------------

Type of Operation: (restaurant, bakery, gift shop, etc.)

Restaurant

Seating Capacity: 92

Signature of Applicant: _____

Charles Masso
Chopmist Charlies
40 Narragansett Ave
Jamestown, R.I. 02835

RECEIVED
TOWN OF JAMESTOWN, R.I.
17 JAN 11 PM 3:31

All Tax & Water Assessments must be paid to date prior to any known Town Council Action.

Your application will not be acted upon should payment of these be in arrears.

For Office Use Only

Application Fee: \$20.00

Paid/Date: January 10, 2017

Approval: Please Sign & Date

Chief of Police:  1-13-17

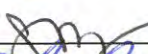
Fire Chief:  1-12-17

Zoning Official:  1-23-17

Water & Sewer Clerk:  2/3/17

Tax Collector:  1/19/17



This application has been **GRANTED/DENIED** by the Jamestown Town Council at a meeting held on the _____ day of _____, 2017 for the period of **March 1, 2017 to February 28, 2018.**

Issued: _____

Cheryl A. Fernstrom, CMC, Town Clerk

letter scal 1127

TOWN OF JAMESTOWN

Application for Private Investigator License Application

New

Renewal

Fee: \$150.00

Date: _____ Private Investigator License #: 1

Applicant(s) Name: South Shore Investigative Agency

Date(s) of Birth: 12/12/1932 / _____

Applicant's Home Address: 203 Seaside Drive, Jamestown

Race: White Hair: Brown Eyes: Blue

Height: 6' Weight: 185 lbs Occupation: Retired

Employer's Name: Malcolm Brown Phone #: 423-0068

Employer's Address: 203 Seaside Drive, Jamestown

Have you ever been arrested? No, if so, what was the offense(s), the location of the offense(s) and the final disposition of the offense(s): _____

Are you licensed to carry a revolver or pistol in the State of Rhode Island? Yes -or- No

Will a revolver or pistol be used in your capacity as a Private Investigator? Yes -or- No

A bond is required in the amount of \$5,000, please provide the following:

Bonding Company Name & Address: Meredith & Clarke OCEAN POINT INS
Ferry Wharf WEST MAIN RD
Jamestown, RI 02835 Middletown

Date Bond Expires: 07/30/2017

Identification card including photograph and fingerprint will be issued upon approval of this license.

Malcolm Brown

Signature of Applicant



For Office Use Only

Record Check: State BCI
 Jamestown BCI

Date Application Cleared: 1-11-17

Date Issuance Not Recommended: _____

Ell

Edward A. Mello, Jamestown Chief of Police

RECEIVED
TOWN OF JAMESTOWN, R.I.
17 JAN -4 PM 1:07

**State of Rhode Island
County of Newport**

The undersigned, being first duly sworn on oath, deposes and says as follows:

In accordance with Title 5, Chapter 5, Section 3 of the RI General Laws (license qualifications under the Private Detective Act), I hereby give oath that the following statements are true:

1. That I am a citizen of the United States or a resident alien;
2. That I have not been convicted in any jurisdiction of a felony;
3. That I have not had any pervious private investigator license or registration denied by the appropriate authority of any local licensing authority;
4. That I have not been declared by any court of competent jurisdiction incompetent by reason of mental defect or disease unless said court has subsequently determined that my competency has been restored;
5. That I do not suffer from habitual drunkenness or from narcotics addition or dependence;
6. That I am of good moral character;
7. That I have such experience as has been gained through **(circle all that apply)**:
 - a. At least five (5) years experience as an investigator or as a police officer with a state, county or municipal police department or with an investigative agency of the United States of America or of any other state, county or municipality with *(name department): Providence Police - 35 yrs* and/ or
 - b. Have received a degree in criminal justice from an accredited college or university *(name of college/university) _____*; and/or
 - c. Have been employed by a private detective as an investigator for at least five (5) years with *(name of business) South Shore Invest agency* and/or
 - d. Have substantively equivalent training or experience. *(Identify): _____*

1/5/17
Date

Malcolm Brown
Signature

Subscribed and sworn to before me in Jamestown, Rhode Island this 4 day of January, 20 17.

Devin Cecilia Gunn
Notary Public

DEVIN J. CARLIN-GAMON
NOTARY PUBLIC-RHODE ISLAND
ID# 757786
MY COMMISSION EXPIRES 04/13/2019

TOWN OF JAMESTOWN
Private Investigator License Application

Private Investigator License #: 1

Class: Renewal

Fee: \$150.00

Business/Organization Name: South Shore Investigative Agency

Location of Premise: P.O. Box 161, Jamestown

Renewal from: July 24, 2017 to February 28, 2018

Applicant(s) Name: Malcolm Brown

Date(s) of Birth: 12/12/1932 /

Home Address: 203 Seaside Drive, Jamestown

P.O. Box 161

Daytime Telephone Number: 423-3230



For Office Use Only

Filing Fee: \$150.00

Paid/Date/Check Number: January 4 2017 # 4352

Approvals: Please Date & Sign

Chief of Police: *[Signature]* 1-11-2017

Fire Chief: *[Signature]* 1-24-17

Zoning Official: *[Signature]* 1-23-17

Tax Collector: *[Signature]* 2-7-17

Water & Sewer Clerk: *[Signature]* 1/19/17

Board of Canvassers: *[Signature]* 1/17/17



This application has been **GRANTED/DENIED** by the Jamestown Town Council at a meeting held on _____ for the period of

March 1, 2017 to February 28, 2018.

Issued: _____

Cheryl A. Fernstrom, CMC, Town Clerk

HPF# _____
(For Office Use Only)



TOWN OF JAMESTOWN
P.O. Box 377
93 Narragansett Ave.
JAMESTOWN, RHODE ISLAND 02835
February 3, 2017

Planning Office - 423-7210
Fax - 423-7226

Ms. Kristine Trocki, Esq., President
Jamestown Town Council
93 Narragansett Avenue
Jamestown, RI 02835

Re: Administrative Subdivision between Westwind Drive and the 1 foot strip adjacent to Westwind Drive

Dear Ms. Trocki:

This letter hereby grants Administrative Subdivision approval in accordance with the Town of Jamestown Subdivision Regulations, RIGL 45-23-37 and the plans entitled "**Administrative Subdivision Plan for Westwind Drive from North Road to Lawn Avenue, Jamestown, Rhode Island**; prepared by **Darveau Land Surveying, Inc., P.O. Box 7918, Jamestown, RI 02835; dated December 7, 2016** based on the following Findings of Fact and subject to the following Conditions of Approval:

A. Findings of Fact

1. This subdivision is for the purpose of deeding a 1-foot wide parcel of Town land located between Westwind Drive and Plat 8, Lots 749, 109, 68, 651 and Pemberton and Lawn Avenues to the Town of Jamestown for incorporation into Westwind Drive for highway purposes;
2. This merger was approved by the Town Council at a meeting on October 3, 2016 and through Town of Jamestown Town Council Resolution #2016-16;
3. The subdivision (merger) is consistent with the requirements of the Jamestown Comprehensive Plan:
4. This is a road and not a buildable lot;
5. No building lot is designed and located in such a manner as to require relief from Article 3, Section 308 of the Zoning Ordinance because it is a roadway and not a buildable lot;
6. There will be no significant negative environmental impacts from the proposed subdivision (merger) as shown on the plans, with all required conditions for approval;
7. The subdivision is a merger and is only subject to future development related to utilities;
8. This subdivision involves Westwind Drive, a public street;
9. The subdivision (merger) provides for safe circulation of pedestrian and vehicular traffic, for adequate surface water runoff;

10. The design and location of streets, utilities, drainage improvements, and other improvements in the are of this subdivision (merger) minimize flooding and soil erosion;
11. The subdivision does not involve buildable lots and therefore potable water is not an issue.

B. Conditions of Approval

1. That payment of a fee in-lieu-of land dedication shall not be required for this subdivision as required by Article IIID of the Jamestown Subdivision Regulations because no new lots are being created for development;
2. This approval shall be recorded with the Town Clerk contemporaneously with the Final Plat; and,
3. This approval shall expire ninety days from the date of approval unless the Final Plat is signed by the Administrative Officer, or designee and recorded in the office of the Town Clerk of the Town of Jamestown.

Sincerely,

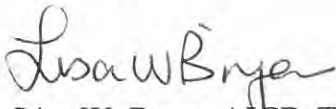

Lisa W. Bryer, AICP, Town Planner
Town of Jamestown

C: Jamestown Planning Commission

MEMORANDUM

Date: February 15, 2017
To: Cheryl Fernstrom
Town Clerk
Jamestown, RI
From: Robert Rodgers
Jamestown
Subject: Request to be placed on the town meeting agenda

Last year I requested an endorsement from the Town Council of pending legislation that would have restricted the carrying of firearms onto school grounds. The Town Council (and the School Committee) did endorse the proposed legislation, but unfortunately it did not pass in the last round. We are trying again this year.

I am requesting that I be placed on the next available town meeting agenda so that I can ask for the Council's endorsement again this year. I have hard copies of the endorsement form, as well as a copy of the current pending legislation, should you or any of the council members request them.

Thank you.

RESOLUTION OPPOSING THE FEDERAL RAILROAD ADMINISTRATION'S
PROPOSAL FOR AN ALTERNATIVE ROUTE FOR THE NORTHEAST CORRIDOR

WHEREAS, the Final Environmental Impact Statement released by the Federal Railroad Administration presents a preferred alternative route as part of the proposed upgrade to the Northeast Corridor which includes a section of nearly 13 miles of new rail line in the State of Rhode Island affecting the Towns of Westerly, Charlestown, Richmond and South Kingstown, as part of the so-called Old Saybrook to Kenyon Bypass; and

WHEREAS, the proposed new rail line will principally affect the Towns of Charlestown and Westerly in Rhode Island, including over 4 miles in Westerly; and

WHEREAS, through lack of specific outreach on the part of the Federal Railroad Administration, the Town of Westerly, its citizens, and impacted property owners were wholly unaware of the proposed new route alignment through Westerly and, as a result, there were no comments received from the Town or interested parties in Westerly during the public review and comment period for the Tier 1 Draft EIS last year; and

WHEREAS, the review and outreach that the Town of Westerly, stakeholders and active members of the community have undertaken since becoming aware of the project on or about December 18, 2016, is the first such engagement that the community has done; and.

WHEREAS, the scope of this project and the impact of the route on the Town of Westerly is significantly negative, as the proposed rail alignment will:

1. Destroy dozens of private homes
 2. Bisect Westerly's Aquifer Protection Overlay District, Wellhead Protection Area, Groundwater Recharge Area, Groundwater Reservoir Area and Town-Owned Conservation Land
 3. Fragment historic and active farmland
 4. Fragment the Grills Preserve and Riverwood Preserve, major land holdings of The Westerly Land Trust
 5. Pass through and/or destroy numerous publicly and privately owned open space otherwise protected in perpetuity
 6. Require several crossings of the Pawcatuck River which has been nominated by Congress as a Wild and Scenic River
 7. Lie entirely within the EPA designated Wood-Pawcatuck Sole Source Aquifer;
- and

WHEREAS, the Federal Railroad Administration has provided a 30 day waiting period on the Final EIS to allow feedback on the preferred alternative which ends on January 30, 2017, a period of time which the Town of Westerly considers inadequate to provide sufficient comments outlining in detail their opposition to the preferred alignment; and

WHEREAS, the Town of Westerly will bear a significant burden due to loss of areas of environmental, historic, agricultural and social importance without commensurate benefits to the community as a whole.

NOW, THEREFORE, BE IT RESOLVED that the Town Council of the Town of Westerly hereby opposes a change to the railroad alignment within its borders, and authorizes its Town Manager to undertake the following:

1. Prepare and send a letter of opposition to the Federal Railroad Administration, along with a request to extend the comment period on the Tier 1 Final EIS to April 1, 2017.
2. Prepare and send a letter to Governor Raimondo of Rhode Island stating the Town of Westerly's opposition to the so-called Old Saybrook to Kenyon Bypass rail alignment as proposed within its borders, and to keep the railroad on its current Right of Way, with copies to all of its federal and state legislators.
3. Prepare and send letters to U.S. Senator Jack Reed, U.S. Senator Sheldon Whitehouse and Congressman James Langevin stating the Town of Westerly's opposition to the so-called Old Saybrook to Kenyon Bypass rail alignment as proposed within its borders, and to keep the railroad on its current Right of Way.
4. Prepare a detailed response to the contents of the Final EIS, as time may allow, including evidence of incomplete and inaccurate data and improper process, to be distributed to all involved agencies and officials.
5. Prepare and send a request to all municipalities within the State of Rhode Island, requesting support of this resolution.
6. Invite a joint resolution with our neighboring towns in Washington County.

ADOPTED: February 6, 2017