



TOWN COUNCIL MEETING
Jamestown Town Hall
Rosamond A. Tefft Council Chambers
93 Narragansett Avenue
Tuesday, October 18, 2016
6:00 PM

The public is welcome to participate in this Town Council meeting. Open Forum offers citizens the opportunity to clarify an item on the agenda, address items not on the agenda, or comment on a communication or Consent Agenda item. Citizens are welcome to speak to the subject of a Public Hearing, and are allowed to speak at the discretion of the Council President or a majority of Councilors present, or at other times during the meeting, in particular during New or Unfinished Business.

Anyone wishing to speak should use the microphone at the front of the room, stating their name and address for the record; comments must be addressed to the Council, not the audience. It is the Town Council's hope that citizens and Councilors alike will be respectful of each other's right to speak, tolerant of different points of view, and mindful of everyone's time.

I. ROLL CALL

II. CALL TO ORDER, PLEDGE OF ALLEGIANCE

III. ACKNOWLEDGEMENTS, ANNOUNCEMENTS, PRESENTATIONS, RESOLUTIONS AND PROCLAMATIONS

- A) Presentation: Update on road work by RI Turnpike and Bridge Authority - Executive Director Buddy Croft and Director of Engineering Eric Offenberg, P.E.

IV. PUBLIC HEARINGS, LICENSES AND PERMITS

V. OPEN FORUM

Please note that, under scheduled requests to address, if the topic of the address is available to be put on the agenda, the Council may discuss the issue

- A) Scheduled to address
B) Non-scheduled to address

VI. COUNCIL, ADMINISTRATOR, SOLICITOR, COMMISSION/COMMITTEE COMMENTS & REPORTS

- A) Administrator's Report: Town Administrator Andrew E. Nota
- 1) Moody's Investors Services Report
 - 2) Town Ordinances
 - 3) League of Cities and Towns Annual Meeting
 - 4) RI Interlocal Risk Management Trust Board
 - 5) Town Staff Update
 - 6) Scheduling of Town Council Meetings, Work Sessions, and Public Hearings - Update

VII. UNFINISHED BUSINESS

- A) Aquaculture activities and expansion off Dutch Harbor: concerns of Westwind Drive neighbors (continued from October 3rd Town Council Meeting); review and discussion and/or potential action and/or vote
 - 1) Letter of Westwind neighbors re: Dutch Harbor aquaculture activities

VIII. NEW BUSINESS

- A) Tax Exemptions for Veterans; review and discussion and/or potential action and/or vote
 - 1) Letter of Commander Leslie Kurtz, Arnold-Zweir Post 22, American Legion
 - 2) Letter of Members of Jamestown Post 9447, Veterans of Foreign Wars
- B) Award of Bid: Jamestown Public Works Department
One (New) Public Works Equipment to Bacher Corporation of Billerica, MA. for an amount not to exceed Forty Three Thousand, Six Hundred, Nine and 18/100 Dollars (43,609.18), as recommended by Public Works Director Michael C. Gray; review and discussion and/or potential action and/or vote
- C) Award of Bids: Jamestown Fire Department and EMS Division
 - 1) One (New) 2017 Ferrara Pumper to Specialty Vehicles of North Attleboro, MA for an amount not to exceed Three Hundred Seventeen Thousand, Two Hundred and Seventeen Dollars (\$317,217.00), as recommended by the Jamestown Board of Fire Wardens (replacement for Engine 2); review and discussion and/or potential action and/or vote
 - 2) One (New) 2017 Ford E450 Life-Line Ambulance to Specialty Vehicles of North Attleboro, MA for an amount not to exceed One Hundred Eighty-Eight Thousand, One Hundred Twenty-Seven Dollars (\$188,127.00), as recommended by the Jamestown Board of Fire Wardens (replacement for Rescue 2); review and discussion and/or potential action and/or vote
 - 3) One (New) Stryker Power-Load Stretcher and System to Stryker Corporation of Portage, MI for an amount not to exceed Twenty Thousand, One Hundred Eighty Dollars (\$20,180.00), as recommended by the Jamestown Board of Fire Wardens; review and discussion and/or potential action and/or vote
- D) Discussion of Sub Committee Development and the appointment of Town Council liaisons. Review and discussion and /or potential action and/or vote.
 - 1) Discussion on recognition and participation of volunteer committees on town business.

- E) Discuss options and best practices for communication amongst Town Council, Town Administrator, Town Staff, Boards and Commissions and the Community. Review and discussion and / or potential action and/or vote.

IX. ORDINANCES AND APPOINTMENTS AND VACANCIES

- A) Appointments and Vacancies
 - 1) Jamestown Housing Authority (One vacancy with an unexpired five-year term ending date of December 31, 2017); duly advertised; no applicants
 - 2) Jamestown Tax Assessment Board of Review – Alternate (One vacancy with a one-year term ending date of May 31, 2017); duly advertised; no applicants
 - 3) Jamestown Tree Preservation and Protection Committee (One vacancy with an unexpired three-year term ending date of December 31, 2016); duly advertised; no applicants

X. CONSENT AGENDA

An item on the Consent Agenda need not be removed for simple clarification or correction of typographical errors. Approval of the Consent Agenda shall be equivalent to approval of each item as if it had been acted upon separately.

- A) Adoption of Council Minutes
 - 1) October 3, 2016 (special meeting)
 - 2) October 3, 2016 (executive session)
 - 3) October 6, 2016 (special meeting)
 - 4) October 6, 2016 (special executive session)
 - 5) October 6, 2016 (joint meeting)
 - 6) October 6, 2016 (joint executive session)

- B) Abatements/Addenda of Taxes
 - Total Abatements: \$88,567.34 Total Addenda: \$86,949.78
 - 1) Motor Vehicles – Abatements to 2011 Tax Roll
 - Account/Abatement Amount**
 - a) 01-0196-73M \$ 427.58
 - 2) Motor Vehicles – Abatements to 2012 Tax Roll
 - Account/Abatement Amount**
 - a) 01-0196-73M \$ 406.65
 - 3) Motor Vehicles – Abatements to 2013 Tax Roll
 - Account/Abatement Amount**
 - a) 01-0196-73M \$ 292.72
 - 4) Motor Vehicles – Abatements to 2014 Tax Roll
 - Account/Abatement Amount**

- a) 01-0196-73M \$ 282.64
- 5) Motor Vehicles – Abatements to 2015 Tax Roll
 - Account/Abatement Amount**
 - a) 01-0196-73M \$ 33.08
- 6) Motor Vehicles – Abatements to 2016 Tax Roll
 - Account/Abatement Amount**
 - a) 07-0844-30M \$ 35.52
 - b) 12-0841-15M \$ 139.37
- 7) Properties/Tangibles – Abatements to 2016 Tax Roll
 - Account/Abatement Amount**
 - a) 02-1390-00 \$ 6,181.30
 - b) 04-0775-75 \$ 641.19
 - c) 04-1037-00 \$ 8,165.80
 - d) 06-0110-65 \$ 5,925.61
 - e) 07-0816-90 \$ 3,463.27
 - f) 07-0894-00 \$ 3,725.70
 - g) 10-0010-20 \$ 5,622.17
 - h) 11-0514-00 \$ 5,297.56
 - i) 12-0448-75 \$18,497.03
 - j) 13-0326-00 \$ 7,260.66
 - k) 13-0326-00 \$11,534.36
 - l) 13-0523-97 \$ 3,269.84
 - m) 13-0525-50 \$ 2,582.58
 - n) 19-0593-00 \$ 4,782.21
- 8) Properties/Tangibles – Addenda to 2016 Tax Roll
 - Account/Abatement Amount**
 - a) 02-0227-50 \$ 6,181.30
 - b) 02-1138-10 \$ 5,622.17
 - c) 03-0748-00 \$ 4,782.71
 - d) 04-0083-02 \$ 2,582.58
 - e) 08-0003-77 \$ 5,925.61
 - f) 11-0090-00 \$ 8,165.80
 - g) 11-0408-00 \$ 7,260.66
 - h) 11-0408-00 \$11,534.36
 - i) 12-1037-00 \$ 5,927.56
 - j) 13-0640-10 \$ 3,725.70
 - k) 13-1956-40 \$ 3,269.84
 - l) 14-0045-90 \$ 3,463.27
 - m) 19-1371-00 \$ 641.19
 - n) 20-0506-00 \$18,497.03

C) One Day Event/Entertainment License

- 1) Applicant: Jamestown Police Department
- Event: Halloween Block Party
- Date: October 31, 2016
- Location: Jamestown Fire Station, 50 Narragansett Avenue

XI. COMMUNICATIONS, PETITIONS, AND PROCLAMATIONS AND RESOLUTIONS FROM OTHER RHODE ISLAND CITIES AND TOWNS

- A) Communications
- 1) Letter of Discover Newport with Audited Financial Statements for the fiscal years ended March 31, 2016 and March 31, 2015 (copy available in the Town Clerk's Office)
 - 2) Letter of David and Mary Dacquino re: replacement of street light at the corner of Walcott Avenue and Brook Street with solar LED street light
 - 3) Letter from RI Planning Council

XII. AGENDA ITEMS FOR THE NEXT MEETING AND FUTURE MEETINGS

XIII. EXECUTIVE SESSION

The Town Council may seek to go into Executive Session to discuss the following items:

- A) Pursuant to RIGL §42-46-5(a) Subsection (1) Personnel (Town Administrator/Fire Department communications and interactions); (2) (Town Administrator's review wrap up); discussion and/or potential action and/or vote in executive session and/or open session

XIV. ADJOURNMENT

Pursuant to RIGL § 42-46-6(c) Notice of this meeting shall be posted on the Secretary of State's website and at the Town Hall and the Jamestown Philomenian Library.

In addition to the two above-mentioned locations, notice also may be posted, from time to time, at the following location: Jamestown Police Station; and on the Internet at www.jamestownri.gov.

ALL NOTE: This meeting location is accessible to the physically challenged. If communications assistance is needed or other accommodations to ensure equal participation, please call 1-800-745-5555, or contact the Town Clerk at 401-423-9800, via facsimile to 401-423-7230, or email to cfernstrom@jamestownri.net not less than three (3) business days prior to the meeting.

THE RHODE ISLAND LEAGUE OF CITIES AND TOWNS

PROVIDENCE, RHODE ISLAND

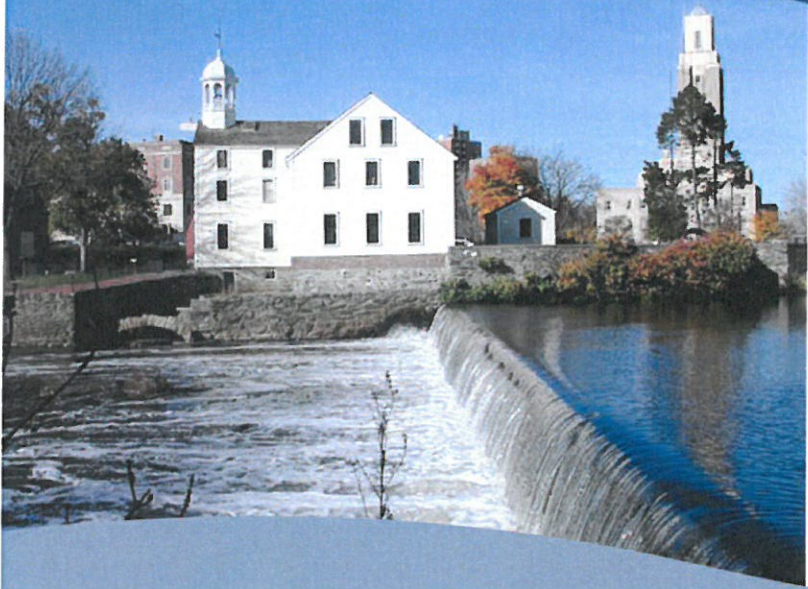

invites your interest in the position of

EXECUTIVE DIRECTOR



RHODE ISLAND LEAGUE OF CITIES AND TOWNS (RILCT): AN EXCEPTIONAL OPPORTUNITY



The Rhode Island League of Cities and Towns (RILCT) is seeking well qualified candidates with significant association or local government management experience, or other relevant experience, for the Executive Director position.

This is an exceptional opportunity to become the chief executive officer of an effective, progressive and respected state municipal league. The RILCT Search Committee and Board of Directors are seeking an effective legislative lobbyist, entrepreneurial leader and effective association manager, with a strong appreciation for good local government and significant experience with public policy issues and governmental decision-making processes. The next Executive Director will have an opportunity to work closely with members of the Board of Directors and other leaders within the RILCT membership to assure continued effectiveness and success, and potentially to enhance the League's service offerings to the membership.

The Executive Director manages a small but capable staff in advocating for the membership's policy goals and delivering several beneficial services to member municipalities.

ABOUT RHODE ISLAND AND OUR CITIES AND TOWNS

Rhode Island, known as the Ocean State, is the eighth least populous state (1,056,300), the second most densely populated after New Jersey, and the smallest state by land

area (37 miles wide and 48 miles long). But its official name is the longest among the states—the State of Rhode Island and Providence Plantations.

Roger Williams and his followers were forced out of the Massachusetts Bay Colony in 1636 over religious differences. Williams founded Providence Plantations as a free proprietary colony, seeking religious and political tolerance. With that history, it was not surprising that Rhode Island was the last of the 13 colonies to ratify the Constitution, after addition of the Bill of Rights.

The state is bordered by Rhode Island Sound and the Atlantic Ocean to the south, to the north and east by Massachusetts, to the west by Connecticut, and shares a short maritime border with New York. Narragansett Bay has more than 30 islands, the largest of which is Aquidneck Island, where Newport is located. It takes relatively little time to drive across the state or to destinations in other New England states.

Local government is vested mostly in the 39 cities and towns, which cover the entire state. Cities and towns have broad home rule, and perform functions commonly assigned to counties in other states, such as public education. Rhode Island state law does not distinguish between a city and a town.

Providence is the largest city (population 178,042) and the state capital. Some cities and towns operate under the strong mayor form of government, while others operate under the council-manager form. Unlike some other New England states, the town meeting form is not prevalent.

Rhode Island's five counties have no governmental functions. They are simply geographic regions, and those areas also are the judicial districts. There also are a number of special purpose units

Rhode Island is known for its picturesque sounds, fine sailing, New England villages and towns, urban sophistication, and grand waterfront mansions. The state also is famous for its seafood cuisine, especially clams, lobster and Rhode Island style clear broth clam chowder.

Much of the economy is based in services, particularly healthcare, tourism and education, but there still is significant manufacturing. CVS Trademark, Textron and other large companies are based in the state. Public school teachers are among the highest paid in the country.

For more information:

- Visit New England: <http://www.visitri.com/state/>

RILCT AND THE EXECUTIVE DIRECTOR POSITION

The League is a private, nonpartisan, nonprofit association of cities and towns formed in 1968 to advocate for the interests of cities and towns and improve the effectiveness of local government. The offices are in Providence, the state capital. RILCT represents municipalities at the General Assembly, before state executive branch and regulatory agencies, in the courts, and on federal issues with the National League of Cities; and provides other services to municipalities and municipal officials.

The Executive Director is appointed by the 21-member Executive Board, elected by and representative of member municipalities. The Executive Director supervises two other RILCT employees and administers a budget of \$645,000. Municipal officials oversee and participate actively in RILCT policy development and services.

More information:

- RILCT: <http://www.rileague.org/>
- National League of Cities: www.nlc.org

THE CANDIDATE

RILCT is seeking an innovative, resourceful and dynamic leader and effective manager, with considerable financial and public management skills, and the highest ethical standards.

The successful Executive Director candidate must engage citizens and be a visionary leader with a hands-on entrepreneurial approach to creating and providing meaningful service programs for municipalities. He or she must have a demonstrated commitment to professionalism and the mission and success of RILCT and our municipalities of all sizes, high energy and great enthusiasm for good local government. The Executive Director must be able to assess the current state and municipal government environment, and work productively with constituent groups, the Governor's Office, the General Assembly and congressional delegation, state and federal agencies, other associations and other potential partners. He or she must be able and willing to work with the Executive Board to establish priorities, refine and implement our RILCT strategic plan, and enhance our working relationships with and service offerings to our membership.





The candidate should have a Master's degree in Public Administration or related field from an accredited institution, with a minimum ten years of progressively higher levels of responsibility in administration of governmental or association programs and services, demonstrated supervisory and organizational development ability, and relevant experience with intergovernmental issues and processes, or an equivalent combination of education, skills and experience.

Desired background, qualifications, experience and characteristics:

- Significant legislative lobbying experience and demonstrated effectiveness
- Able and willing to lead active and effective RILCT advocacy efforts on significant municipal issues, based on the membership's adopted policies, maintaining the scrupulous non-partisan role of RILCT
- Politically astute, with demonstrated sound professional judgment and thorough understanding of the appropriate respective roles of elected officials and RILCT staff
- Demonstrated ability to work productively with and for elected or appointed governing bodies
- Demonstrated strong financial and budget development and management skills, with entrepreneurial aptitude

- Able and willing to make sound, timely decisions after consideration of relevant information and alternatives, including evaluation of results of prior decisions, and adequate consultation with the Executive Board and others
- Ability to exercise sound professional judgment, initiative, tact and discretion in assisting the membership in developing policies, in presenting recommendations to resolve challenging issues, and bringing the membership's goals to fruition



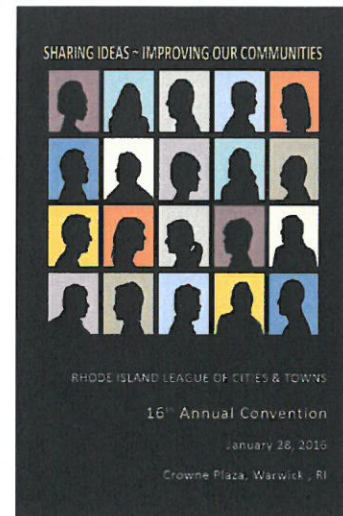
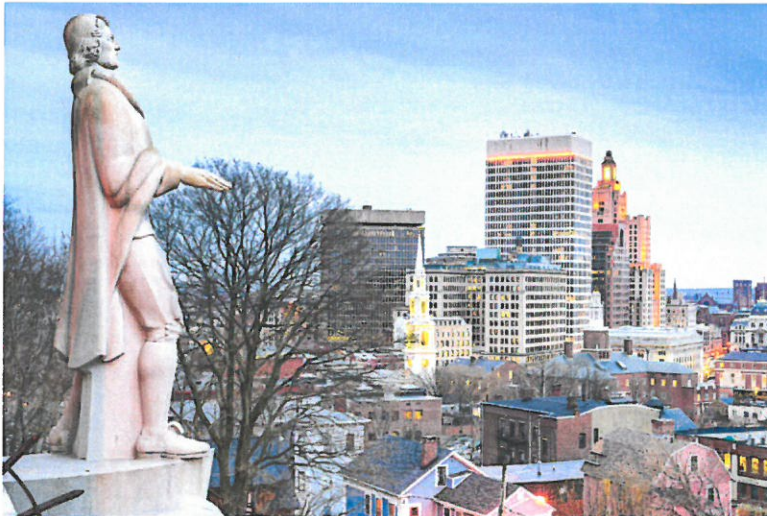

- Ability to understand a broad range of public policy issues and look for opportunities for the RILCT membership, in the interests of good local government
- Good at relationship building, able to build credibility and work productively with municipal, state and federal elected officials and professional staff members, including the Governor's Office and legislators
- Understanding of and appreciation for the forms of municipal government in Rhode Island, and for the tradition of strong municipal home rule
- Openness and creativity to work with the Executive Board, municipal officials and staff to capitalize on needs and opportunities to provide broader service offerings to assist municipal officials with their responsibilities, such as better education and training, in a financially sustainable way
- General working knowledge of public finance and municipal insurance
- Ability to emphasize to the membership the value of their municipal association, and willingness to encourage capable municipal officials to become actively involved
- Able and willing to provide leadership and supervision to a small association staff, assuring that they function collaboratively as valuable, accessible and helpful resources to municipal officials, with a strong culture of service, creativity and excellence
- Leadership style that delegates authority and responsibility, motivates staff, encourages employees to offer constructive input with meaningful consideration, and empowers staff members to make productive contributions to serving our membership based on clear communication of general expectations without micromanagement, but with accountability and recognition of achievements
- Able and willing to keep staff members well informed about issues and priorities, to enhance their ability to serve our cities and towns of all sizes
- Strong appreciation for the character and diverse culture of our cities and towns, with a realization that continuing changes present new opportunities and needs
- Demonstrated ability to keep membership informed about significant trends, opportunities and challenges that should be addressed
- Creative, flexible, lifelong learner, open to new ideas, able and willing to develop and recommend innovative but sound policies and membership services
- Strong negotiation and problem solving skills to address future opportunities, needs and challenges
- Strong public presentation and written communications skills and ability to address complex municipal issues clearly and persuasively, in the media and otherwise
- Effective interpersonal skills and willingness to reach out to the RILCT membership and citizens and emphasize crucial local government issues and needs
- Ability and willingness to oversee planning for productive RILCT annual conferences, legislative meetings, training workshops and other meetings for the benefit of the membership
- Impeccable integrity, committed to high ethical standards and transparent government operations, ability to sustain consistent compliance with legal requirements and establish a high level of credibility with citizens, municipal officials and RILCT employees
- Able and willing to seek productivity, member service and citizen information improvements through cost effective information technology enhancements and innovation
- Commitment to maintaining productive working relationships with other associations and institutions, and influential citizen groups and business leaders, and all potential partners, to advance the interests of good municipal government
- Sound personnel management experience with willingness and ability to make timely and fair personnel decisions
- Commitment to productive personal and staff professional development

COMPENSATION

The starting salary will be market competitive, depending on experience, education and other qualifications. Attractive benefits.

HOW TO APPLY

To apply for this outstanding opportunity, send letter of interest, resume and salary history by email to:

Ellis Hankins, Senior Vice President, The Mercer Group, Inc., Raleigh, North Carolina

Email: ellis.hankins@gmail.com

Cell voice and text: 919-349-8988

Website: www.mercergroupinc.com

The Mercer Group, Inc., a firm that provides executive search and other consulting services to local governments and other public and private sector clients nationwide, is assisting the RILCT Search Committee with this Executive Director search.

Receipt of applications will be acknowledged by email. If timely acknowledgement is not received, please contact Mr. Hankins.

First review of applications will begin by **October 18, 2016**. Interviews with selected finalists will be conducted in November.

RILCT is an Equal Opportunity Employer and values diversity across the work force, in order to serve our membership and the citizens of our cities and towns.



RHODE ISLAND

League of Cities and Towns

Presentation to the Board of Directors

September 20, 2016

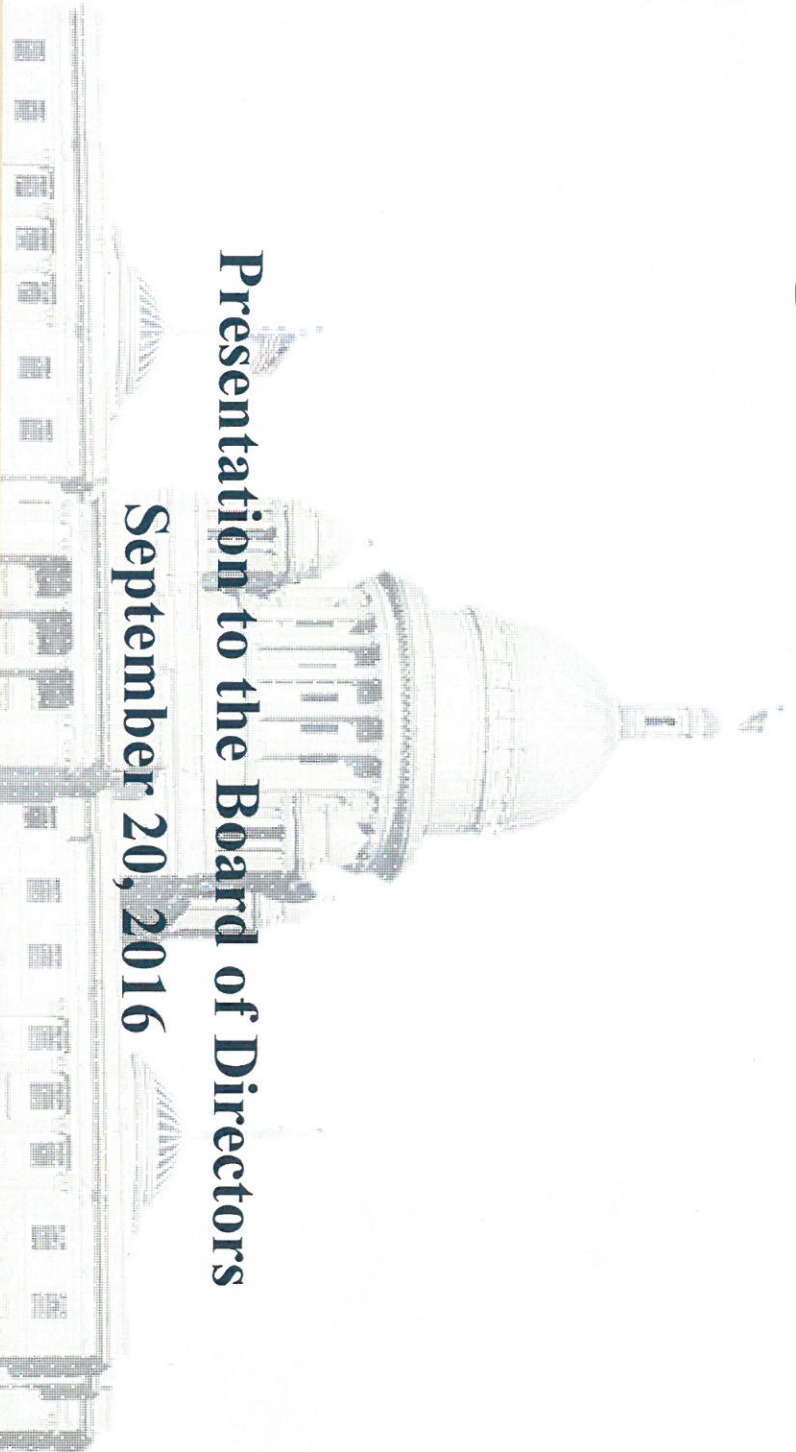

Citrin Cooperman

- Effective 9/1, LGC+D became the Providence office of CCC
- 800+ firm headquartered in NY
- Founded in 1979; top 20 CPAs
- A dozen offices located in the Northeast corridor
- www.citrincooperman.com



Summary of Results

- Services provided:
 - Accounting services – preparation for audit
 - Audit of the League
 - Propose correcting/adjusting entries
 - Prepare draft financial statements



Summary of Results (continued)

Auditors' Report	<ul style="list-style-type: none"> Unmodified opinion
Proposed Audit Adjustments	<ul style="list-style-type: none"> Reconcile net assets to prior year audited ending balance = \$3,390 Adjust trade show deferred revenue/revenue = \$41,530 Reclassify REAP revenue to dues revenue = \$97,337 Correct transfer from REAP checking account to money market account and record interest earned = \$40,215 Accrue underpayment of retirement contribution = \$887
Uncorrected Misstatements	<ul style="list-style-type: none"> None



Financial Statement Highlights

- Cash and CDs increased \$59K
 - *All cash is fully ensured by the FDIC*
- Accounts receivable, *Other* decreased \$14K
 - *Timing of payment from RIRMT under consulting arrangement*
- Deferred Revenue, *Direct Energy* decreased \$17.6K
 - *Amortization of renewal bonus; done in December 2016*
- Net Assets increased \$57K



Financial Statement Highlights

(continued)

- Revenue increased \$26K or 7%
- New members: *Cities of Central Falls and Woonsocket*
- Total revenues (including REAP) trend:

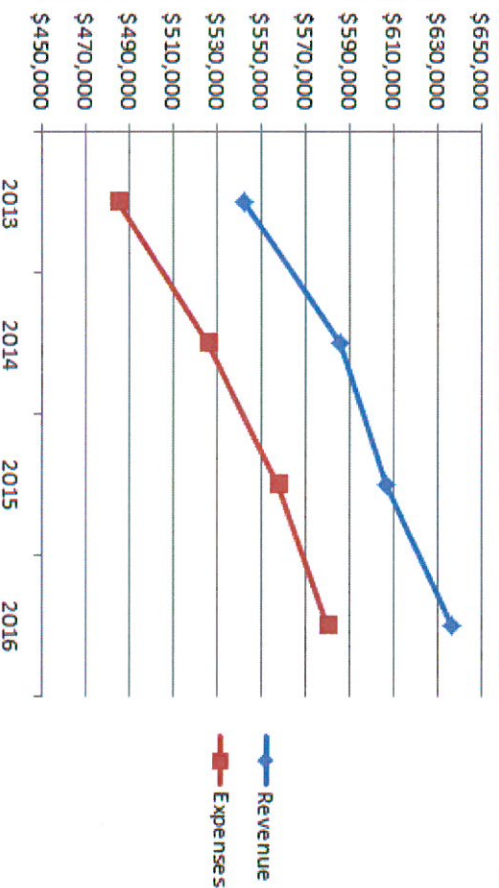

- Expenses increased \$22K or 4%
- Increase in health insurance premiums and retirement
 - FY 15 health insurance understated by 1 mo.; FY 14 overstated



Financial Statement Highlights

(continued)

- Footnotes
- *Retirement Plans (FN-2)*
 - Updated to reflect actual plan provisions in place
 - Includes subsequent event
- *Otherwise, no new FNs*



Observations

- **Retirement**
 - *Although not specifically allowed by Personnel Policies, one employee allocates a portion of his retirement contribution to wages at his discretion, for which no written documentation is retained to support the activity.*
 - *Personnel Policies specify the Executive Director's retirement contribution as a percentage of gross annual salary, yet actual & budgeted contributions exceed that amount.*
 - *Personnel Policies specify retirement contributions as a percentage of gross annual salary, yet the amount is not defined (i.e. are bonuses included?).*



Recommendations

- **Retirement**
 - *Personnel Policies should be revisited to ensure the provisions of the “Retirement Program” section meet management’s intent and practice, and revised accordingly, including defining gross annual salary.*
 - *Management may want to consider limiting the number of times per year changes in allocations between wages and retirement contributions can be made, if still allowed, and update Personnel Policies accordingly.*
 - *Written documentation should be required and retained for all changes to employee elections for contribution investment.*



Auditors' Required Communications

(continued)

- Significant accounting policies – *no changes*
- Accounting estimates and management judgment – *no changes*
- Sensitive financial statement disclosures – *revenue recognition policies as disclosed in Note 1*
- Other use of financial statements – *not aware*
- Representations from management – *signed upon acceptance of audit by BOD*



Auditors' Required Communications

(continued)

There were no:

- Significant audit issues
- Alternative accounting treatments discussed with management
- Disagreements with management
- Consultations with other accountants
- Significant unusual transactions
- Difficulties encountered in performing the audit

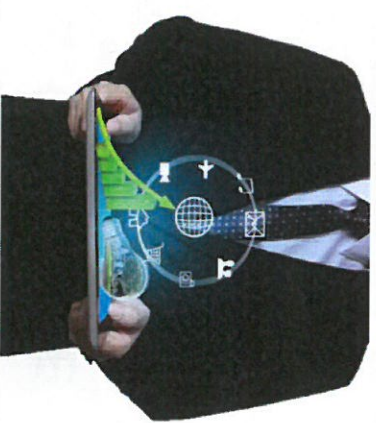

Contact Information

We appreciate the opportunity to make this presentation and to be of service to the League

Judith Ventura Enright, Director, jenright@citrincooperman.com

Cassie Fidalgo, Senior, cfidalgo@citrincooperman.com



CITRINCOOPERMAN®

Accountants and Advisors

10 Weybosset Street, Suite 700 + Providence, RI 02903 + 401-421-4800 + www.lgcd.com



THE GATHERING STORM: THE LOOMING RHODE ISLAND FINANCIAL CRISIS IN PUBLIC PENSIONS AND OTHER POST EMPLOYMENT BENEFITS

It has been widely reported that the State of Rhode Island has "fixed" its public pension problems by a variety of legislative reforms. While it is true that the State has enacted and implemented important legislative reforms that address the problem, it persists and may yet explode in our very midst unless immediately addressed. As recently reported in the Providence Business News based upon data from the Rhode Island Department of Revenue, Division of Municipal Finance, pension plans for 18 Rhode Island cities and towns remain in critical status. Even more significantly, only 12 communities have begun funding trusts for Other Post Employment Benefits (OPEB). Of those, the best is a mere 35.5 % of the funded liability and the rest are funded at a much lower percentage. By way of example, the City of Providence has a \$1.149 billion liability that is entirely unfunded. Furthermore, effective June 15, 2017, Government Accounting Standards Board (GASB) Standard 75 will go into effect requiring cities and towns to clearly present as a liability on their balance sheets the present value of the entire OPEB liability less any funding. It appears reasonably clear that the effect of GASB 75 will be to highlight most of Rhode Island's cities and towns as balance sheet insolvent, which will present a new set of financial challenges.

The Seminar will discuss the accounting, actuarial and legal ramifications of this dire public fiscal crisis and the perspectives of the cities and towns and the affected employees and retirees in light of the existing and impending GASB requirements and the recent rulings of the Superior Court for Providence County in the City of Woonsocket health benefits case and the City of Cranston pension benefit case, and the impending ruling in the City of Providence pension and health benefits case.

This event has been approved for 1.5 hours of Continuing Legal Education credit by the Rhode Island Supreme Court

THE FOLLOWING PANELISTS WILL SHARE THEIR PERSPECTIVES:

- Ernie Almonte, RSM US LLP
- William M. Dolan III, Esq. | Donoghue Barrett & Singal
- Paul A. Doughty, Esq., President | Providence Fire Fighters
- Carly B. Iafrate, Esq. | Law Offices of Carly Beauvais Iafrate
- Daniel W. Sherman | Sherman Actuarial Services, LLC
- Angel Taveras, Esq. | Greenberg Traurig LLP | Former Mayor of Providence

Friday, October 14, 2016
12:00-2:00PM

Rhode Island Convention Center, Ballroom B

[Member Login](#)

Focused insurance and risk management solutions for Rhode Island public entities since 1986.

[Search](#)[Property/Liability](#)[Workers' Compensation](#)[Health](#)[Dental](#)[Group Life](#)[OPEB](#)[Loss Prevention](#)[Wellness](#)[Claims](#)[About Us](#)[Contact Information](#)[Home](#) / [About Us](#) / [Who is The Trust?](#)

First One in the Pool

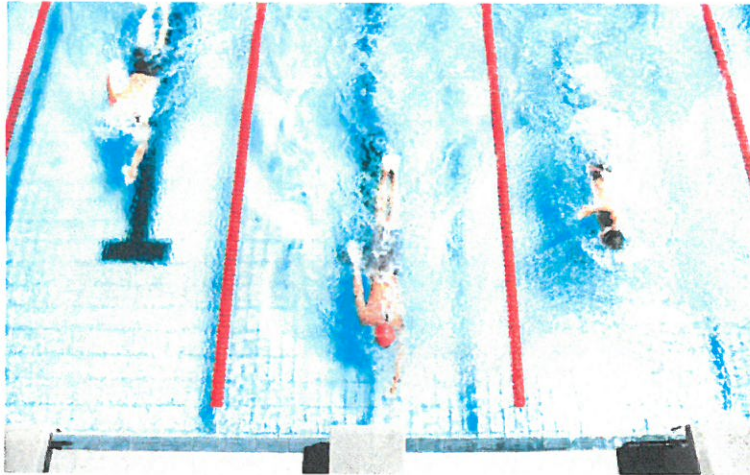

The Trust is the pioneer and undeniable leader of intergovernmental risk-sharing pooling in Rhode Island. Born from a national insurance crisis in the 1980s that affected numerous states, The Trust became Rhode Island's first intergovernmental risk-sharing pool in 1986 when six municipal entities came together through the Rhode Island League of Cities and Towns to develop affordable insurance solutions for Rhode Island's local governmental entities.

During that critical time, you might say that The Trust became a life ring, a first of its kind risk-sharing insurance pool for Rhode Island local government brought about by special legislation advanced by the Rhode Island League of Cities and Towns through the General Assembly.

It's important not to confuse The Trust with an insurance agency or broker. Rather, The Trust is a true risk-financing and sharing partnership that works to keep insurance premiums affordable by helping its Member-Owners learn and consistently practice the highest standards of public sector risk management.

The Trust is focused exclusively on Rhode Island public sector entities and by virtue of the State enabling legislation allowing it to exist, no other type of business interest can be pursued.

Because of this singular focus, The Trust is the only insurance and risk management provider in Rhode Island that has the know-how, experience, and tools necessary to provide public sector entities —municipalities, school districts, and special purpose districts— with highly specialized risk management solutions designed to help reduce claims and minimize losses.

Who is The Trust?

[Our Mission and History](#)[Boards and Committees](#)[Conference Center](#)[Employment Opportunities](#)[News and Announcements](#)[Trust Publications](#)[Bylaws](#)[Partners and Associations](#)[Membership Overview](#)

Quick Links

Member Login



Focused insurance and risk management solutions for Rhode Island public entities since 1986.

Home / About Us / Who is The Trust? / Our Mission and History

- [Search](#)
- [Property/Liability](#)
- [Workers' Compensation](#)
- [Health](#)
- [Dental](#)
- [Group Life](#)
- [OPEB](#)
- [Loss Prevention](#)
- [Wellness](#)
- [Claims](#)
- About Us**
- [Contact Information](#)

Our Mission

The Rhode Island Interlocal Risk Management Trust is Member-owned and managed, providing the highest risk management service opportunities to Rhode Island public entities and the people they serve.

View Our History

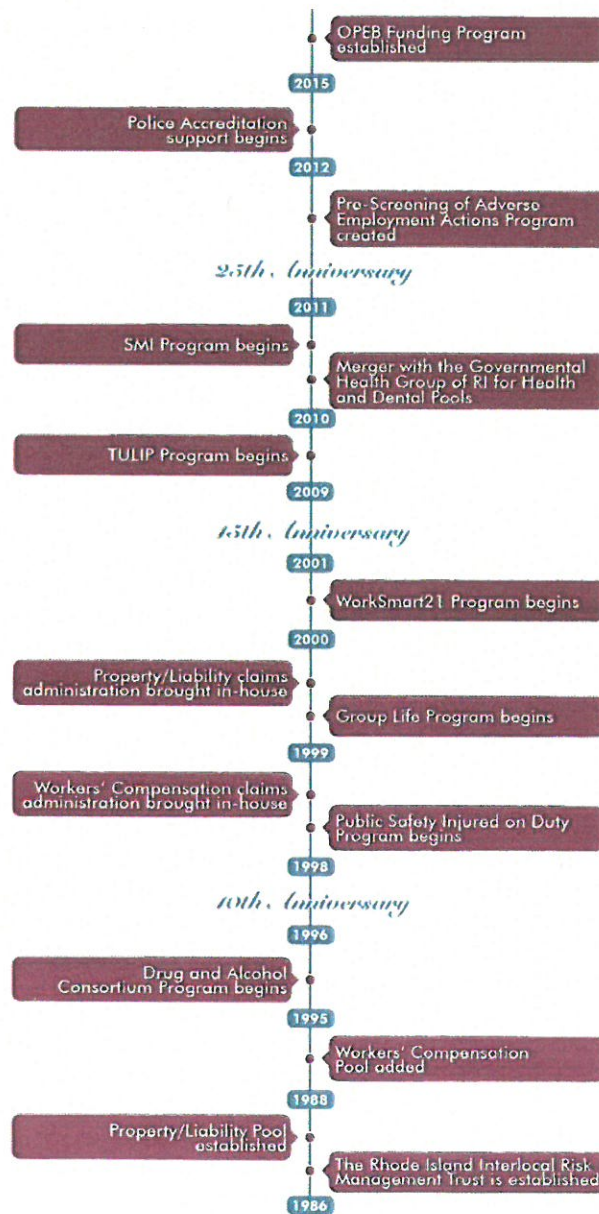

Who is The Trust?

Our Mission and History

[Boards and Committees](#)

[Conference Center](#)

[Employment Opportunities](#)

[News and Announcements](#)

[Trust Publications](#)

[Bylaws](#)

[Partners and Associations](#)

[Membership Overview](#)

[Member Login](#)

*Focused insurance and risk management solutions for
Rhode Island public entities since 1986.*

[Search](#)[Property/Liability](#)[Workers' Compensation](#)[Health](#)[Dental](#)[Group Life](#)[OPEB](#)[Loss Prevention](#)[Wellness](#)[Claims](#)[About Us](#)[Contact Information](#)[Home](#) / [About Us](#) / [Boards and Committees](#)

Boards and Committees

Board of Trustees

CHAIR

Stephen A. Alfred

Town Manager

Town of South Kingstown

VICE CHAIR

Peter A. DeAngelis, Jr.

Town Manager

Town of Barrington

Scott Avedisian

Mayor

City of Warwick

Joseph A. Balducci

Chief Financial Officer

Cranston Public Schools

Jeffry Ceasrine, P.E.

Town Engineer

Town of Narragansett

Thomas E. Coyle, III

Town Manager

Town of East Greenwich

Maryanne Crawford, CPA, SFO

Chief Financial Officer

South Kingstown School Department

James A. Diosa

Mayor

City of Central Falls

Craig T. Enos

Director of Administration

Northern Rhode Island Collaborative

[Who is The Trust?](#)

Boards and Committees

[Management Committee](#)[Underwriting Committee](#)[Employee Benefits Committee](#)[Investment and Audit Commit](#)[Risk Management Committee](#)[Officers of the Trust](#)[Conference Center](#)[Employment Opportunities](#)[News and Announcements](#)[Trust Publications](#)[Bylaws](#)[Partners and Associations](#)[Membership Overview](#)

Douglas Fiore

Director of Finance and Administration
Tiverton School Department

Lori A. Miller

Business Administrator
Lincoln Public Schools

Mark S. Stankiewicz

Town Administrator
Town of Charlestown

Antonio A. Teixeira

Town Administrator
Town of Bristol

EX-OFFICIO

Daniel L. Beardsley

Executive Director
Rhode Island League of Cities and Towns

Quick Links

[Submit a Claim](#)
[Training and Events](#)
[FAQs](#)
[Change Your Password](#)

[About Us](#)
[Contact Us](#)
[Site Map](#)

[Terms of Use](#)
[Privacy Policy](#)
[Security](#)



Oliver Stedman Government Center
4808 Tower Hill Road; Suite 116
Wakefield, RI 02879
401-783-3370

PUBLIC NOTICE

File Number: 2015-09-105 (modification) Date: August 24, 2016

This office has under consideration the application of:

Walrus & Carpenter Oysters LLC
c/o Jules Opton-Himmel
73 Harrison Street
Providence, RI 02909

for a State of Rhode Island Assent to: add sugar kelp to the species that can be cultured at this site. Kelp is grown during the winter and harvested in the spring.

Project Location:	Dutch Island Harbor
City/Town:	Jamestown
Waterway:	Dutch Island Harbor

Plans of the proposed work may be seen at the CRMC office in Wakefield. An electronic copy of the application can be sent upon request to the CRMC Aquaculture Coordinator.

In accordance with the Administrative Procedures Act (Chapter 42-35 of the Rhode Island General Laws) you may request a hearing on this matter.

You are advised that if you have good reason to enter protests against the proposed work it is your privilege to do so. It is expected that objectors will review the application and plans thoroughly, visit site of proposed work if necessary, to familiarize themselves with the conditions and cite what law or laws, if any, would in their opinion be violated by the work proposed.

If you desire to protest, you must attend the scheduled hearing and give sworn testimony. A notice of the time and place of such hearing will be furnished you as soon as possible after receipt of your request for hearing. If you desire to request a hearing, to receive consideration, it should be in writing (**with your correct mailing address, e-mail address and valid contact number**) and be received at this office on or before September 23, 2016.

WINTER PROFILE

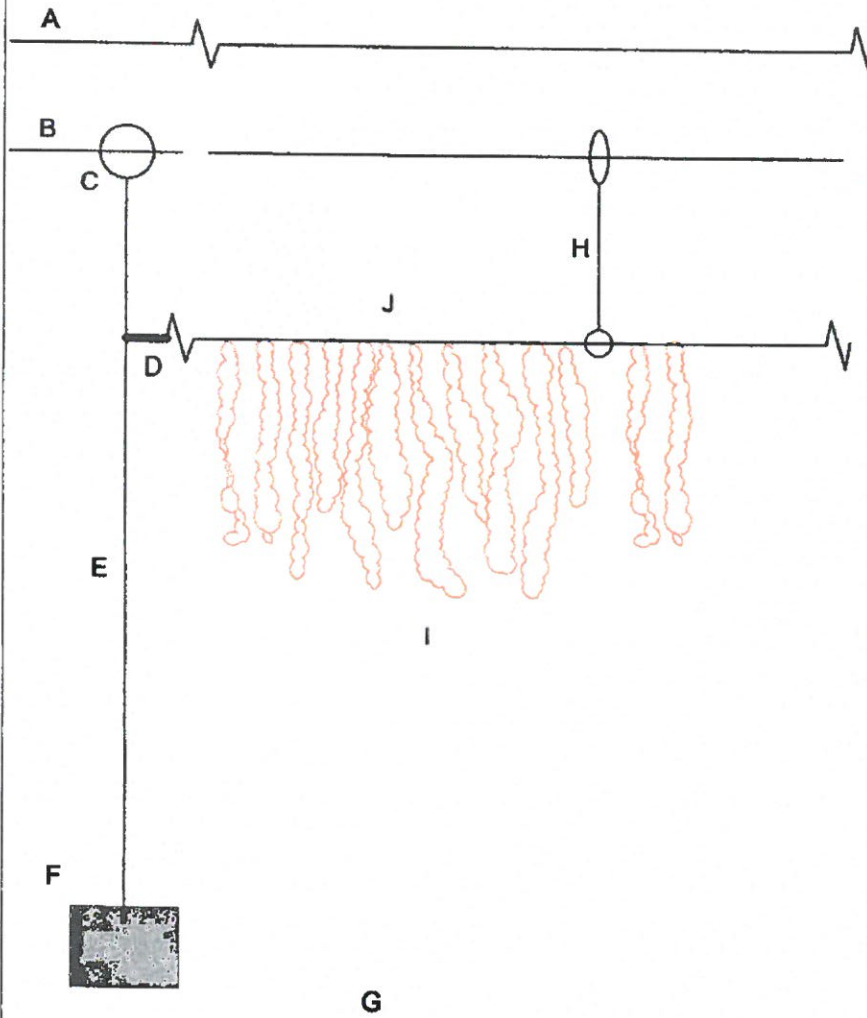

SUMMER PROFILE

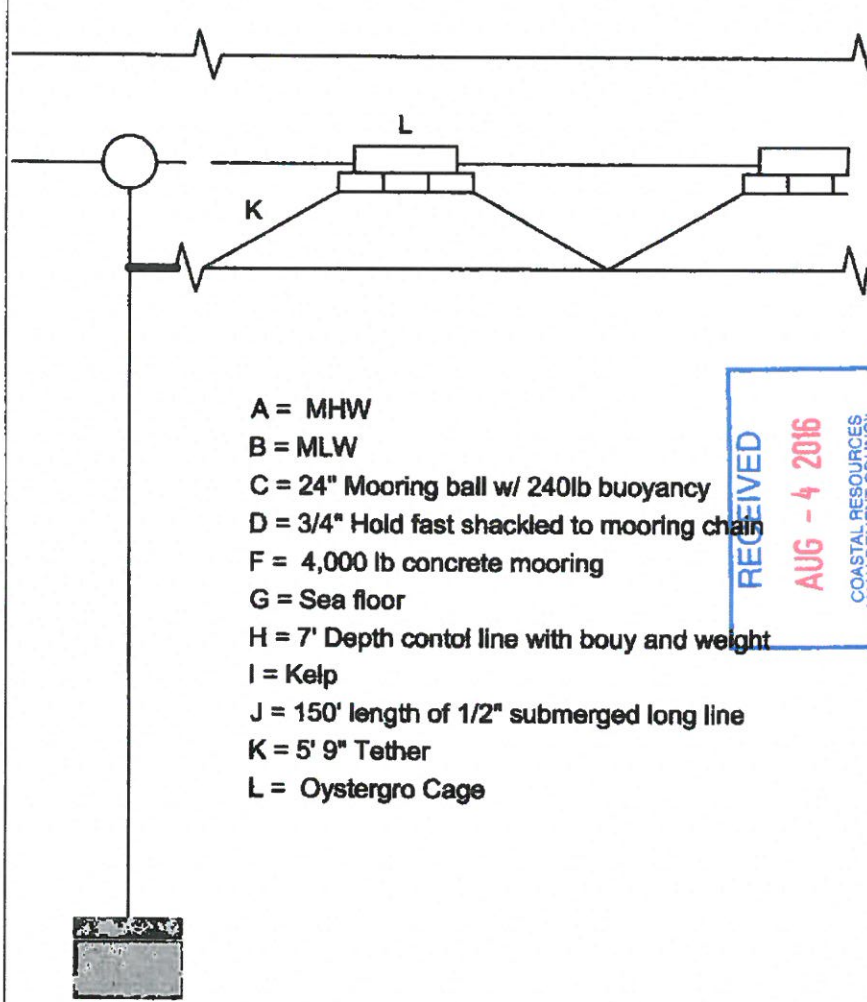

- A = MHW
- B = MLW
- C = 24" Mooring ball w/ 240lb buoyancy
- D = 3/4" Hold fast shackled to mooring chain
- F = 4,000 lb concrete mooring
- G = Sea floor
- H = 7' Depth control line with bouy and weight
- I = Kelp
- J = 150' length of 1/2" submerged long line
- K = 5' 9" Tether
- L = Oystergro Cage

RECEIVED
 AUG - 4 2016
 COASTAL RESOURCES
 MANAGEMENT COUNCIL

VALRUS AND CARPENTER
 OYSTERS LLC
 PREPARED JANUARY 23, 2015

PROPOSED SITE A - SECTION AT
 SHALLOWEST DEPTH
 (WINTER and SUMMER)
 BUTCH ISLAND, JAMESTOWN, RI

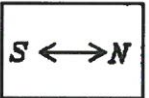

SCALE 1" = 8'

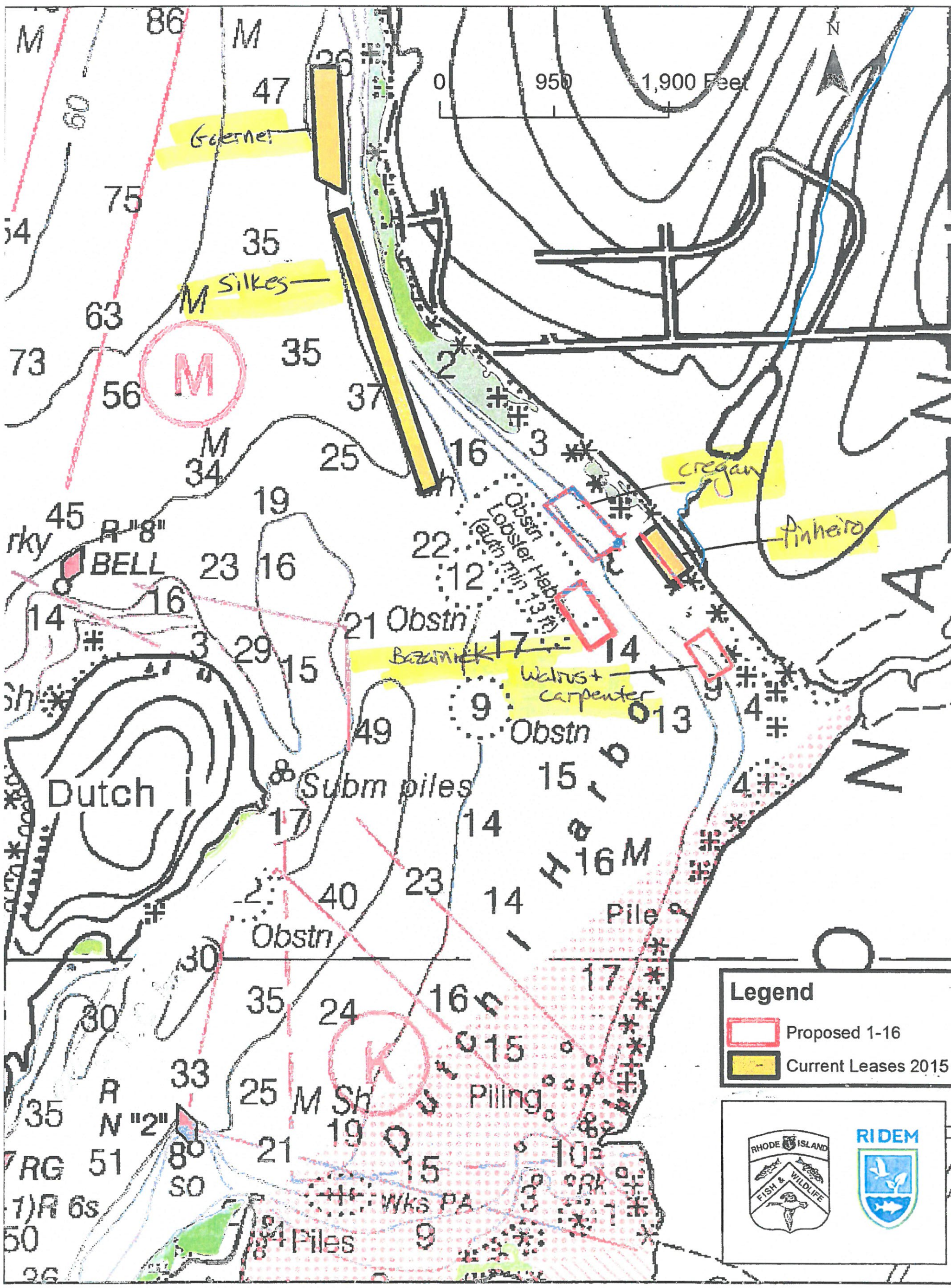

Legend

- Proposed 1-16
- Current Leases 2015

RHODE ISLAND FISH & WILDLIFE
RIDEM

To the Jamestown Town Council:

9-27-16

We would like to make you aware of what is happening in Dutch Harbor concerning aquaculture. What was once a pristine scenic vista has now turned into a working aquaculture farm with what will eventually have approximately 1400 cages and possibly twice that number of floats and buoys in one area. Great Creek had been one of the most scenic areas in Jamestown's waters. But now it is covered in floats, oyster cages, light markers and buoys. We are directly impacted by what has become a commercial shell fishing site. All this activity will have a negative effect on our property values, particularly for those with riparian right in Dutch Harbor. Our use and access to Dutch Harbor for our moorings and boats is being drastically interfered with and limited.

We would like to request that no more applications or modifications be approved until all the current approved leases have been set up so everyone can see what the full impact will be on the area. Some of the floats are more intrusive than others. We were hoping that a low profile type of float could be used that does not sit above the water. Also, is it possible to move the leases farther out, as they take up space for moorings and boating navigation. We also don't know why adjacent home owners with riparian rights are not notified directly about these applications, because they certainly impact the home owners.

Thank you for your considerations.

Alan and Lorraine Katz
52 Westwind Drive
Jamestown, R.I. 02835

Edmund Sybertz and Sharon Purdie
60 Westwind Drive
Jamestown, R.I. 02835

Al and Anne Yole
24 West Passage Drive
Jamestown, R.I. 02835

Scott and Kelly Palumbo
12 Westwind Drive
Jamestown, R.I. 02835

Robert and MaryJo Braisted
85 Westwind Drive
Jamestown, R.I. 02835

Charles and Susan Long
80 Westwind Drive
Jamestown, R.I. 02835

Robert Powers
30 Westwind Drive
Jamestown, R.I. 02835

Jim and Renee McCooey
70 Westwind Drive
Jamestown, R.I. 02835

RECEIVED
TOWN OF JAMESTOWN, R.I.
16 SEP 27 PM 2:02



TOWN OF JAMESTOWN
93 NARRAGANSETT AVENUE
P.O. Box 377
JAMESTOWN, RHODE ISLAND 02835

TO: HONORABLE TOWN COUNCIL
FROM: ANDREW E. NOTA, TOWN ADMINISTRATOR
SUBJECT: VETERANS TAX EXEMPTION
DATE: October 13, 2016

In review of the Towns present Veterans Tax Exemption limits and based on several inquiries from within our Veterans community, provided on the attached spreadsheet is a comparison of similar exemption limits applied in several other Town's within the state: Barrington, Bristol, E. Greenwich, Middletown, Narragansett, Newport, N. Kingstown, Portsmouth, and S. Kingstown. This comparison outlines the differences, by community, for the Veterans with 100% Service Connected Disabilities and the Veterans and Widow/Widowers Exemption programs.

Veterans and Widows/Widowers Exemption:

The following information has been provided by the Town's Tax Assessor, Ken Gray regarding the Veterans and Widows/Widowers of Veterans tax exemption. This community program presently offers a \$5,000 reduction in an eligible Veteran or Widowers assessment. When this exemption is applied to real estate, at \$8.58/M, it amounts to a tax credit of \$42.90. When the exemption is applied to motor vehicles, at \$14.42/M, the exemption credit is \$72.10. In order to clear up the disparity between real estate and motor vehicles, if this exemption is to be adjusted, the Assessor has recommended consideration be given to one of the two following options: 1) Either offer two exemption amounts, as is done in several other towns (for example, offer a \$20,000 exemption when applied to real estate and a \$12,000 exemption when applied to motor vehicles); or simply offer a Tax Credit, which would be the same for everyone, as we do similarly for the eligible volunteer members of the Fire Department.

This year the Town has recognized 386 people benefiting from the Veterans and Widows Exemption. The total cost to the town during the 2016-17 tax year is \$15,836. For comparison purposes, using Tax Credits rather than assessment reductions, below are some projected costs to the town at various Tax Credit amounts:

@ \$100 Tax Credit per recipient the total town cost would be:	\$38,600
@ \$200 Tax Credit per recipient the total town cost would be:	\$77,200
@ \$400 Tax Credit per recipient the total town cost would be:	\$154,400
@ \$500 Tax Credit per recipient the total town cost would be:	\$193,000

Veterans with 100% Service Connected Disabilities:

The Town offers Veterans with 100% Service Connected Disabilities a tax exemption of \$2,000 off their assessments. When this exemption is applied to real estate (\$8.58/M), it amounts to a tax reduction of \$17.16. When the exemption is applied to motor vehicles, at \$14.42/M, the exemption amount is \$28.84.

The Service Connected Disability Program is state mandated, with exemption amounts that vary widely from community to community. At \$2,000, Jamestown ranks in a tie with Foster for the second lowest exemption amount in this category. Only Coventry, at \$1,000, offers a lesser exemption limit. At the high end of the exemption scale, Westerly offers disabled Veterans an exemption of \$49,100 off their assessments, which in Jamestown would amount to a Tax Credit of \$421.28. The average Tax Credit offered by neighboring town's totals \$234.

Jamestown presently has eleven Veterans who qualify for this disability exemption, costing the town \$188.76. If we were to increase the exemption amount using Tax Credits, with 11 qualifiers, the cost to the town would be as follows:

With a Tax Credit of \$100 the total cost to the town would be	\$1,100
With a Tax Credit of \$200 the total cost to the town would be	\$2,200
With a Tax Credit of \$300 the total cost to the town would be	\$3,300
With a Tax Credit of \$400 the total cost to the town would be	\$4,400
With a Tax Credit of \$500 the total cost to the town would be	\$5,500

As referenced on the attached Exemption Comparison worksheet, similar Towns vary greatly in how they fund the various Veterans Exemptions. In terms of the *Veteran* specific Exemptions, the credits vary from a low in Jamestown of \$42.90 for real estate or \$72.10 for motor vehicles to a high in other communities of \$250 real estate and \$371.70 for motor vehicles. In respect to the *Veterans with a Service Disability* Jamestown stands at the tax credit limit of \$17.16 for real estate and \$28.84 for motor vehicles while other can be as high as \$442.34 in real estate and \$743.42 in motor vehicles. There clearly exists a wide disparity on how each community has chosen to address this issue and the likelihood is that the existing limits have evolved over time for an abundance of reasons specific to each individual community.

In review of this information and in speaking with the Assessor after his research into this matter, there appears to be sufficient basis for an adjustment, inclusive of an exemption expansion to the existing limits the Town has in place at this time.

Should the Council require any additional information in this regard, please contact me at your convenience.

INTRODUCTION

This report is the result of a survey of Rhode Island's 39 cities and towns relating to veterans', elderly, and other tax exemptions. Because personal exemptions are subject to change, the user of this publication should contact a local tax assessor for the most current information available. This survey was conducted by the Division of Municipal Finance with the cooperation of local tax assessors. We are grateful for the cooperation the tax assessors have provided.

Section I - Veterans' Exemptions

The veterans' exemptions are prescribed by Title 44, Chapter 3, Sections 4, 5 and 24 of the General Laws of Rhode Island. To be eligible, a veteran must have served or been discharged under conditions other than dishonorable and served during wartime periods as specified by law. The eligible wartime periods are:

World War I
World War II, December 7, 1941 - December 31, 1946
Berlin: May 9, 1945 to October 2, 1990. Cold War/Show of Strength
Korean Conflict, June 27, 1950 - January 31, 1955
Quemay and Matsu: August 23, 1956 to June 1, 1963. Show of Force and Escort
Vietnam: July 1, 1958 to July 3, 1965. Advisory/US Troops Ordered to Undertake Offensive Position
Vietnam Conflict, February 28, 1961 - May 7, 1975
Vietnam Conflict & RVNMC: July 3, 1965 to March 8, 1973. U.S. Troops Ordered to Offensive Position
Korea: October 1, 1966 to June 30, 1974. Treaty Commitment
El Salvador: January 1, 1981 to February 1, 1992. Advisory/Training
Persons who actually served in the Grenada or Lebanon Conflicts of 1983 - 1984.
Persian Gulf: August 2, 1990 to November 30, 1995. Operation Desert Shield & Desert Storm
Persian Gulf Conflict, the Haitian Conflict, the Somalian Conflict and the Bosnian Conflict at anytime during the period beginning August 2, 1990 and ending May 1, 1994, or in any conflict or undeclared war for which a campaign ribbon or expeditionary medal was earned, and who was honorably discharged from the service, or who, if not discharged, served honorably, or of the unmarried widow or widower of that person.
Southwest Asia: December 1995 ongoing. Maritime Intercept Operation, Operation Southern Watch, Operation Vigilant Sentinel, Operation Northern Watch, Operation Desert Thunder, Operation Desert Fox, Exercise Intrinsic Action, Exercise Iris Gold, Operation Desert Spring
Former Republic of Yugoslavia: December 20, 1995 - ongoing. Operation Joint Endeavor, Joint Guard and Force

Haiti: April 1, 1995 to January 31, 2000. Operation: UNMHI, U.S. for Haiti, USSPTG-Haiti
Kosova, March 24, 1999 to Present
Operation Noble Eagle, September 12, 2001 to Present
Operation Enduring Freedom, September 12, 2001 to Present
Operation Iraqi Freedom, September 12, 2001 to Present

Please note there are other military engagements that encompass a smaller period of eligible time for which veteran's exemptions are available. It is highly recommended that you contact the local tax assessor for eligibility.

Exemptions shall be applied to the property in the municipality where the person resides, and if there is not sufficient property to exhaust the exemption, the person may claim the balance in any other city or town where the person may own property. An exemption shall not be allowed to persons who are not legal residents of the State of Rhode Island. To qualify for an exemption, appropriate documentation will be required by the municipality at time of application. The seven exemption categories include:

Veterans' regular exemption

Unmarried widow/widower of qualified veteran

Veterans' exemption for totally disabled through service connected disability

Veterans' exemption partially disabled through service connected disability

Gold Star parents' exemption

Prisoner of war exemption

Specially adapted housing exemption

Section II - Elderly Exemptions

The elderly exemptions are prescribed by Title 44, Chapter 3, and Sections 13, 13.1, 13.2, 16, 32 and 39. This elderly exemption section describes the type of program, the amount of exemption or tax credit, income requirements and other eligibility requirements required by the various cities and towns. It is highly recommended that you contact the local tax assessor for eligibility.

Included in this section is an explanation of the Property Tax Relief Program administered by the State Division of Taxation and a copy of form RI-1040H Property Tax Relief Claim.

Section III - Miscellaneous Exemptions

A number of other exemptions are available to eligible citizens and businesses in the various cities and towns of Rhode Island. Section III lists the most commonly used exemptions, but this report is not inclusive of all exemptions. This survey should be used as a guide and more detailed information can be obtained by contacting the individual city or town assessor.

The notes page cites the sections of the Rhode Island General Law for the exemptions listed under miscellaneous exemptions.

SECTION I
VETERANS' EXEMPTIONS

VETERANS' EXEMPTION PROGRAMS

<u>Community</u>	<u>Regular Exemption/ Tax Credit</u>	<u>Unmarried Widow/ Widower</u>	<u>Totally Disabled Service Connected</u>	<u>Partially Disabled Service Connected</u>	<u>Gold Star Parents</u>	<u>Prisoner of War</u>	<u>Specially Adapted Housing</u>	<u>Application Deadline</u>
Barrington	\$13,900 ¹ \$ 3,000 ²	\$13,900 ¹ \$ 3,000 ²	\$13,900 ¹ \$ 3,000 ²	None	\$13,900 ¹ \$ 3,000 ²	None	100%	March 15
Bristol	\$250.00	\$250.00	\$323.50	\$66.00	\$227.00	\$340.00	Variable	March 15
Burrillville	\$225.00⁵	\$225.00⁵	\$300.00⁵	None	\$225.00	\$900.00	Variable	December 31
Central Falls	\$3,856	\$3,856	\$3,856	None	\$3,856	\$11,009	Variable	March 15
Charlestown*	\$150.00	\$150.00⁶	\$500.00⁶	None	\$5,100	\$500.00⁶	\$500.00	January 31
Coventry	\$8,000	\$8,000	\$ 1,000	None	\$3,000	\$15,000	\$10,000	December 31
Cranston	\$7,972 ¹ \$3,000 ²	\$7,972 ¹ \$3,000 ²	\$50,000** \$ 3,000 ²	None	\$12,131 ¹ \$ 3,000 ²	\$39,852 ¹ \$ 3,000 ²	\$79,705 ¹ \$ 3,000 ⁵	March 15
Cumberland	\$20,378	\$20,378	\$40,756	None	\$20,378	\$20,378	None	March 15
East Greenwich	\$110.00	\$110.00	\$300.00	None	\$115.00	\$745.00¹ \$743.60²	<u>100%¹</u> \$297.44²	March 15
East Providence	\$7,200 ¹ \$3,000 ²	\$7,200 ¹ \$3,000 ²	\$14,400 ¹ \$6,000 ²	None	\$10,900 ¹ \$4,500 ²	None	\$14,400 ¹ \$4,500 ²	March 15
Exeter	\$5,000	\$5,000	None	None	\$3,000	None	None	March 15

Bold print represents tax credit rather than exemption off of assessment.

*Credit available for all honorably discharged veterans including those not eligible under prescribed service dates

**Assessor is authorized to grant an exemption of \$50,000 a year aggregated for 5 years up to \$250,000 of the real property

<u>Community</u>	<u>Regular Exemption/ Tax Credit</u>	<u>Unmarried Widow/ Widower</u>	<u>Totally Disabled Service Connected</u>	<u>Partially Disabled Service Connected</u>	<u>Gold Star Parents</u>	<u>Prisoner of War</u>	<u>Specially Adapted Housing</u>	<u>Application Deadline</u>
Foster	\$1,000	\$1,000	\$2,000	None	\$3,000	None	\$10,000	January 31
Glocester	\$267.10	\$267.10	\$641.04	None	\$63.72	\$318.60	\$10,000	March 15
Hopkinton	\$6,700	\$6,700	\$13,500	None	\$21,500	None	\$30,000	March 15
Jamestown	\$5,000	\$5,000	\$2,000	None	\$5,000	None	\$10,000	February 15
Johnston	<u>\$4,970¹</u> <u>\$3,000²</u>	<u>\$4,970¹</u> <u>\$3,000²</u>	\$9,980	None	\$7,450	\$24,850	\$16,580	March 15
Lincoln	\$10,000	\$10,000	\$15,000	None	\$5,000	\$11,000	\$11,000	April 15
Little Compton ⁷	<u>\$18,000¹</u> <u>\$1,000²</u>	<u>\$18,000¹</u> <u>\$1,000²</u>	Based on Income	None	None	\$30,000	\$10,000	February 15
Middletown	\$25,777	\$25,777	\$51,555	None	\$38,676	\$31,290	\$106,083	March 15
Narragansett	\$55.00	\$55.00	\$110.00	None	\$165.00	\$400.00	100%	March 15
New Shoreham	\$170,356	\$170,356	\$170,356	None	None	None	\$10,000	December 31
Newport	\$21,400	\$21,400	\$18,000	None	\$3,000	\$52,000	\$10,000 or 10%	March 15
N. Kingstown	<u>\$12,500¹</u> <u>\$10,000²</u>	<u>\$12,500¹</u> <u>\$10,000²</u>	<u>\$14,600¹</u> <u>\$11,000²</u>	None None	<u>\$11,000¹</u> <u>\$8,750²</u>	<u>\$54,700¹</u> <u>\$26,993²</u>	\$21,040	March 15

Bold print represents tax credit rather than exemption off of assessment.

~ Volunteer – Fire/Rescue Exemption \$700

<u>Community</u>	<u>Regular Exemption/ Tax Credit</u>	<u>Unmarried Widow/ Widower</u>	<u>Totally Disabled Service Connected</u>	<u>Partially Disabled Service Connected</u>	<u>Gold Star Parents</u>	<u>Prisoner of War</u>	<u>Specially Adapted Housing</u>	<u>Application Deadline</u>
N. Providence	\$5,000	\$5,000	\$10,000	None	\$5,000	\$5,000	\$15,000	December 31
N. Smithfield	\$45.50	\$45.50	\$91.00	None	\$136.50	\$15,000	\$10,000	December 31
Pawtucket	$\frac{\$8,290^1}{\$2,000^2}$	$\frac{\$8,290^1}{\$2,000^2}$	$\frac{\$16,670^1}{\$4,000^2}$	None	$\frac{\$12,475^1}{\$3,000^2}$	$\frac{\$16,670^1}{\$4,000^2}$	$\frac{\$16,670^1}{\text{See Assessor}}$	March 15
Portsmouth	$\frac{\$14,530^1}{\$1,400^2}$	$\frac{\$14,530^1}{\$1,400^2}$	$\frac{\$19,315^1}{\$2,800^2}$	None	\$7,265	\$71,540	\$18,390	January 31
Providence	$\frac{\$8,138^1}{\$1,000^2}$	$\frac{\$8,138^1}{\$1,000^2}$	$\frac{\$16,330^1}{\$1,000^2}$	None	$\frac{\$24,468^1}{\$3,000^2}$	\$40,780	100% to \$45,000	March 15
Richmond	\$6,825	\$6,825	\$10,000	None	\$1,500	\$15,000	\$10,000	April 15
Scituate	\$46.10	\$46.10	\$92.20	None	\$112.11	\$112.11	\$373.70	March 15
Smithfield	\$4,000	\$4,000	\$10,000	None	\$6,000	\$15,000	\$20,000	March 15
S. Kingstown	\$146.00	\$146.00	\$272.00	None	\$378.00	\$430.00	\$710.00	June 7
Tiverton	\$10,225	\$10,225	\$20,460	None	\$6,140	\$30,690	\$10,225	March 15
Warren	$\frac{\$9,584^1}{\$5,500^2}$	$\frac{\$9,584^1}{\$5,500^2}$	\$19,291	None	\$9,215	None	\$10,000	December 31
Warwick	\$138.40	\$138.40	\$346.00	None	\$207.60	\$519.00	\$20,000⁸	March 15

Bold print represents tax credit rather than exemption off of assessment.

<u>Community</u>	<u>Regular Exemption/ Tax Credit</u>	<u>Unmarried Widow/ Widower</u>	<u>Totally Disabled Service Connected</u>	<u>Partially Disabled Service Connected</u>	<u>Gold Star Parents</u>	<u>Prisoner of War</u>	<u>Specially Adapted Housing</u>	<u>Application Deadline</u>
W. Greenwich	\$50.00	\$50.00	\$150.00	Pro-Rated	\$75.00	\$100.00	\$10,000	March 15
W. Warwick	\$ 170.00 ¹ \$ 1,000. ²	\$ 170.00 ¹ \$ 1,000. ²	\$ 200.00 ¹ \$ 3,000. ²	None	\$225.00	\$190.00	\$190.00	March 15
Westerly	\$31,609 ⁵	\$31,609 ⁵	\$36,244 ⁵	None	\$36,244 ⁵	\$53,071 ⁵	\$36,244 ⁵	April 15
Woonsocket	\$79.38 ⁵	\$79.38 ⁵	\$396.90 ^{5/6}	None	\$238.14 ⁵	None	\$10,000	January 31

- 1 - Exemption for real estate
- 2 - Exemption for motor vehicle
- 3 - Only on real estate, not on motor vehicle
- 4 - Or 10% of assessed valuation, whichever is greater
- 5 - Can be applied to Motor Vehicle if no real estate
- 6 - In addition to veteran's exemption
- 7 - In addition to the previously provided exemption, any veteran who is discharged from the military or naval service of the United States under conditions other than dishonorable, or an officer who is honorably separated from military or naval service, who is determined, under applicable federal law by the veterans administration of the United States to be totally and permanently disabled through a service connected disability, who owns a specially-adapted homestead, which has been acquired or modified with the assistance of a special adaptive housing grant from the Veteran's Administration and that meets Veteran's Administration and Americans with disability act guidelines from adaptive housing or which has been acquired or modified, using proceeds from the sale of any previous homestead, which was acquired with the assistance of a special adaptive housing grant from the veteran's administration, the person or the person's surviving spouse is exempt from all taxation on the homestead.
- 8 - Paraplegic Veteran

Bold print represents tax credit rather than exemption off of assessment.

VETERANS EXEMPTION COMPARISON

Exemption	Property Type	Jamestown		Barrington		Bristol		E. Greenwich		Middletown	
		Asmt Amt	Tax Credit	Asmt Amt	Tax Credit	Asmt Amt	Tax Credit	Asmt Amt	Tax Credit	Asmt Amt	Tax Credit
Veterans	Real Estate	\$5,000	\$42.90	\$13,900	\$119.26	\$29,137	\$250.00	\$12,820	\$110.00	\$25,777	\$221.17
	Motor Vehicle	\$5,000	\$72.10	\$3,000	\$43.26	\$29,137	\$250.00	\$12,820	\$110.00	\$25,777	\$371.70
Widow	Real Estate	\$5,000	\$42.90	\$13,900	\$119.26	\$29,137	\$250.00	\$12,820	\$110.00	\$25,777	\$221.17
	Motor Vehicle	\$5,000	\$72.10	\$3,000	\$43.26	\$29,137	\$250.00	\$12,820	\$110.00	\$25,777	\$371.70
Disabled	Real Estate	\$2,000	\$17.16	\$13,900	\$119.26	\$37,704	\$323.50	\$34,965	\$300.00	\$51,555	\$442.34
	Motor Vehicle	\$2,000	\$28.84	\$3,000	\$43.26	\$37,704	\$323.50	\$34,965	\$300.00	\$51,555	\$743.42

Exemption	Property Type	Narragansett		Newport		N. Kingstown		Portsmouth		S. Kingstown	
		Asmt Amt	Tax Credit	Asmt Amt	Tax Credit	Asmt Amt	Tax Credit	Asmt Amt	Tax Credit	Asmt Amt	Tax Credit
Veterans	Real Estate	\$6,410	\$55.00	\$21,400	\$183.61	\$11,700	\$100.39	\$14,530	\$124.67	\$17,016	\$126.00
	Motor Vehicle	\$6,410	\$55.00	\$21,400	\$308.59	\$10,000	\$144.20	\$1,400	\$20.19	\$17,016	\$126.00
Widow	Real Estate	\$6,410	\$55.00	\$21,400	\$183.61	\$11,700	\$100.39	\$14,530	\$124.67	\$17,016	\$126.00
	Motor Vehicle	\$6,410	\$55.00	\$21,400	\$308.59	\$10,000	\$144.20	\$1,400	\$20.19	\$17,016	\$126.00
Disabled	Real Estate	\$12,820	\$110.00	\$18,000	\$154.44	\$13,630	\$116.95	\$19,315	\$165.72	\$31,702	\$252.00
	Motor Vehicle	\$12,820	\$110.00	\$18,000	\$259.56	\$11,000	\$158.62	\$2,800	\$40.38	\$31,702	\$252.00

Note: Some towns offer their exemptions in the form of Tax Credits (like the \$700 credit we give to our Volunteers) and some offer assessment reductions. For the ease of comparison this chart shows exemptions as both Assessment Credits and Tax Credits, using our Tax Rates of \$8.58 per M and \$14.42 per M.

Average Veterans/Widows Tax Credit	\$150.00
------------------------------------	----------

Average Disabled Veterans Tax Credit	\$234.00
--------------------------------------	----------

Arnold-Zweir Post 22, American Legion

P.O. Box 41

Jamestown, RI 02835

September 21, 2016

RECEIVED
TOWN OF JAMESTOWN, R.I.
16 SEP 22 PM 12:47

Jamestown Town Council
93 Narragansett Avenue
Jamestown, RI 02835

Dear Councilors:

I am writing to express our support for your current effort to re-evaluate the amount of Town's Veterans' Tax Credit. The amount of this tax credit has not changed in many decades, and the research you are doing to find a fair amount is much appreciated.

As was suggested in an August 18 Jamestown Press editorial, money is not the driving issue here—it is more a matter of appreciation. A tax benefit to veterans is meaningful acknowledgment, an ongoing affirmation of the men and women who served their country via military service.

Thank you for your efforts in this respect. If Jamestown's American Legion Post can support this process in any way, we would be honored to do so.

Respectfully,

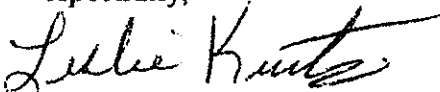

Leslie Kurtz

Commander

Arnold-Zweir Post 22, American Legion

2

September 29, 2016

Kristine S. Trocki, President
Jamestown Town Council
93 Narragansett Avenue
Jamestown, RI 02835

RECEIVED
TOWN OF JAMESTOWN, R.I.
16 SEP 33 PM 1:50

Dear Ms. Trocki,

Subject: Tax Exemption for Jamestown Veterans

Jamestown's VFW Post 9447 is following with interest the recent Jamestown Press articles regarding tax exemptions for veterans.

Central to this issue is not money, but rather the town's appreciation and acknowledgement of military service to our country. Just the fact that this issue is being discussed and re-considered is powerful affirmation for the men and women who have served.

If we can contribute anything to your research and discussion, please let us know. Post members appreciate your consideration and review of this veteran-related issue.

Kindest regards,

Members of Jamestown VFW Post 9447



Daniel Ustick (423-2638)
by direction

**Town of
Jamestown, Rhode Island**

PO Box 377
Jamestown, RI 02835- 1509
Phone: (401) 423-7220
Fax: (401) 423-7229



Date: October 13, 2016

To: Andrew Nota
Town Administrator

From: Michael Gray
Public Works Director

RE: Bid Award
New Closed Cab, Four Wheel Drive, Articulating Tractor with Attachments

The FY 16/17 capital budget included funding to purchase a piece of equipment for removing snow and ice from the sidewalks during the winter. The Department of Public Works completed a review of many pieces of equipment to determine the most effective tool for conducting snow and ice removal from Jamestown's sidewalks. After our review which included demonstrations with vendors we determined that an articulating tractor would be best suited for our operations. A Bid was prepared for a New Closed Cab, Four Wheel Drive, Articulating Tractor with Attachments that include a snow plow, snow blower, hydraulic broom, bucket, and spreader to apply deicing materials.

The Bid was advertised and one was received and opened on October 13, 2016. I have reviewed the specifications for the equipment that will be provided and recommend that the **Bid for a New Closed Cab, Four Wheel Drive, Articulating Tractor with Attachments be awarded to Bacher Corporation for an amount not to exceed \$43,609.18.**

Attached is a copy of the catalog provided by the vendor that shows the equipment that will be purchased.

ALL NEW PROFESSIONAL SNOWBLOWER

Model # **SB648**

COMPATIBLE WITH: **440 | 235**



- Commercial-grade dual-stage snow blower designed for productivity
- 48"-wide clearing path moves snow up to 27" deep
- 18" four-blade impeller, sawtooth auger, 237° chute rotation
- Heavy-duty steel and cast iron construction

SNOW BLOWER

Model # **SB454 (54") | SB448 (48")**

COMPATIBLE WITH: **440 | 235**



- Heavy-duty 2-stage snow blower, perfect for occasional to moderate use
- No-maintenance gearbox
- 14" four-blade impeller, serrated auger, 237° chute rotation



POWER ANGLE BLADE

Model # **BD248 (48") | BD260 (60")**

BD272 (72")



COMPATIBLE WITH:

440 | 235 | 430 MAX | 525 | 415 | 230 | UM 428

- Blade angles hydraulically 30° left or right
- Reversible cutting edge for longer life
- Spring-loaded, forward-tilt safety trip
- Optional poly edge and scarifier wear edge available



BUILT FOR ALL YOU DO



STEINER



JAMESTOWN FIRE DEPARTMENT

INCORPORATED 1897



Telephone 401/423-0062
Fax 401/423-7278

50 Narragansett Avenue
Jamestown, RI 02835

October 11, 2016

Christina D. Collins
Finance Director
Town of Jamestown
93 Narragansett Avenue
Jamestown, RI 02835

Re : Engine 2 and Rescue 2 Recommendation

The Jamestown Fire Department Board of Fire Wardens hereby recommends the Town Council of the Town of Jamestown award the bid for the delivery and acceptance of a new 2017 Ferrara Pumper (Engine 2) from Specialty Vehicles of North Attleboro Massachusetts. This new pumper will replace the current 1984 EONE Pumper (Engine 2). The cost of the vehicle is not to exceed Three Hundred Seventeen Thousand, Two Hundred and Seventeen Dollars (\$ 317,217.00).

Also

The Jamestown Fire Department Board of Fire Wardens hereby recommends the Town Council of the Town of Jamestown award the bid for the delivery and acceptance of a new 2017 Ford E450 Life-Line (Rescue 2) Ambulance from Specialty Vehicles of North Attleboro Massachusetts. This new Rescue will replace the current 1998 Ford Ambulance (Rescue 2). The cost of the vehicle is not to exceed One Hundred Eighty-Eight Thousand, One Hundred Twenty-Seven Dollars (\$ 188,127.00).

Also

The Jamestown Fire Department Board of Fire Wardens hereby recommends the Town Council of the Town of Jamestown award the bid for the delivery, installation and acceptance of a new Stryker Power-Load Stretcher and System to Stryker Corporation of Portage, Michigan. The cost of the new Stretcher System is not to exceed Twenty Thousand, One Hundred and Eighty Dollars.

Sincerely,

Howard F. Tighe
Deputy Chief

Per the order of the Board of Fire Wardens



Similar Truck Shown

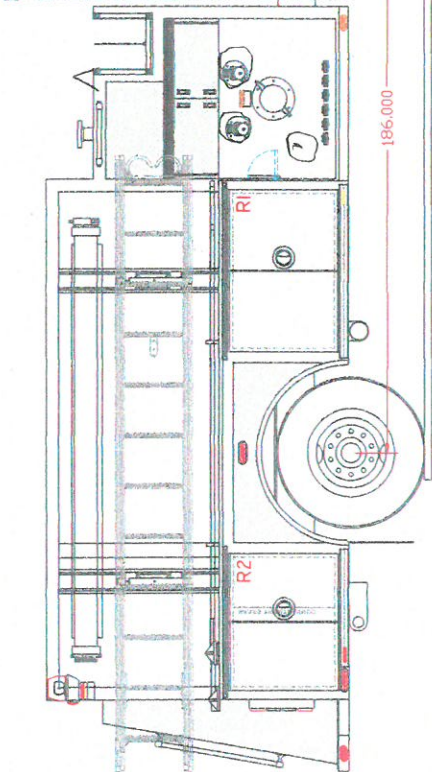
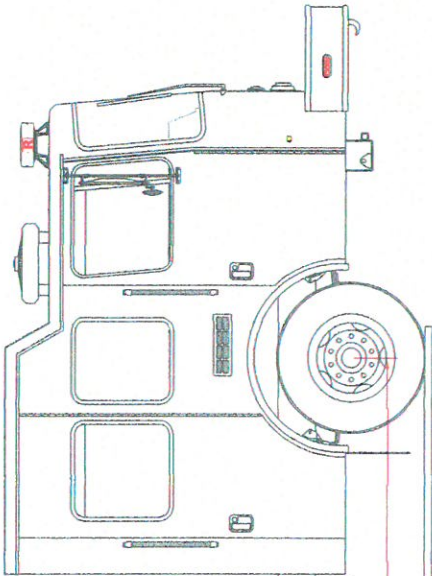
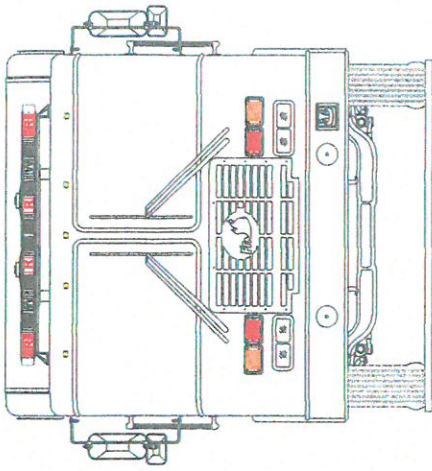

FERRARA
 FERRARA FIRE APPARATUS, INCORPORATED
INTRUDER 2 PUMPER (STOCK)
 1500 GPM HALE QMAX PUMP
 1000 GALLON WATER TANK

DRAWING IS A VISUAL REPRESENTATION OF SPECIFIED APPARATUS. IN THE EVENT OF DISCREPANCIES BETWEEN SPECIFICATIONS AND DRAWING, THE SPECIFICATIONS SHALL PREVAIL. SOME DIMENSIONS AND DETAILS MAY NOT BE SHOWN OR NOTED. A DETAILED DRAWING WILL BE DONE AFTER RECEIPT OF CONTRACT AND SPECIFICATIONS.

DRAWING IS A VISUAL REPRESENTATION OF A SPECIFIED PUMP PANEL. FERRARA FIRE APPARATUS, INC. RESERVES THE RIGHT TO MAKE ANY CHANGES TO OPERATORS' PANEL WITHOUT NOTICE DUE TO PUMP MANUFACTURER'S PLUMBING REQUIREMENTS AND/OR SPECIFICATIONS.

HOSEBED CAPACITY
 NOTE: HOSE CAPACITY WAS SPECIFIED AT TIME OF APPROVAL. DRAWING COMPLETION. OVERALL HEIGHT MAY INCREASE DUE TO HOSE AMOUNT. PLEASE SUPPLY AMOUNT OF HOSE TO BE STORED IN HOSE BED.

LADDER STORAGE COMPLIMENT
 1-24' 2-SECTION LADDER (PEL-24)
 1-14' ROOF LADDER (PRL-14)
 10' ATTIC LADDER (FL-10)

COMP. / OPENING	INTERIOR
L1	43W X 60H 43W X 64H X 12/25D
L2	50W X 28H 50W X 32H X 12D
L3	36W X 60H 36W X 64H X 12D/TRANS.
R1	43W X 28H 43W X 28H X 25D
R2	36W X 28H 36W X 28H X TRANS.
E1	46W X 28H 46W X 28H X 34D

IT IS UNLAWFUL TO COPY OR REPRODUCE ANY OF ALL OF THIS DRAWING WITHOUT THE WRITTEN PERMISSION OF FERRARA FIRE APPARATUS, INC. ANY VIOLATION OF THE LAW, ORDINANCES AND ITEM LOCATIONS ARE FULLY THE RESPONSIBILITY OF THE USER. DIMENSIONS AND ITEM LOCATIONS ARE SHOWN FOR INFORMATION ONLY. DIMENSIONS MAY VARY WITHOUT NECESSARY NOTICE. SOME DETAILS MAY NOT BE SHOWN NECESSARY DURING CONSTRUCTION. SOME DETAILS MAY NOT BE SHOWN.

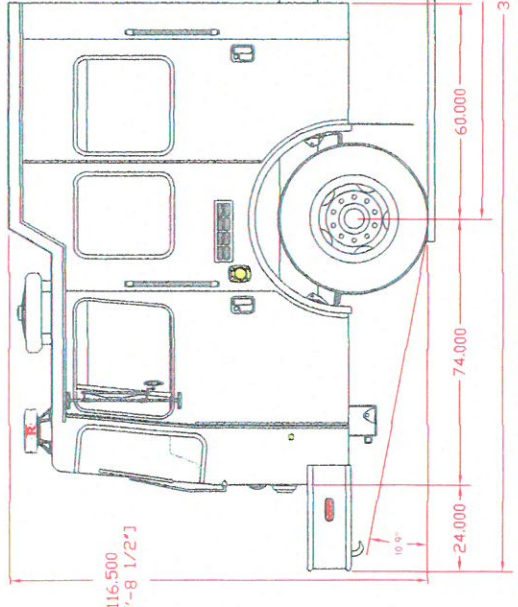
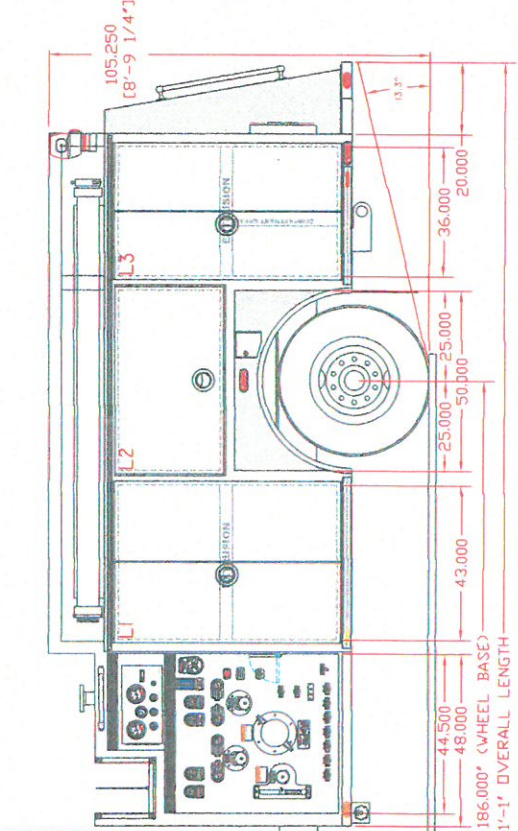
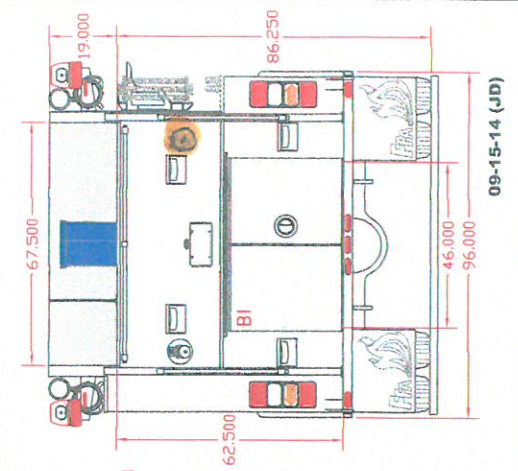

09-15-14 (JD)

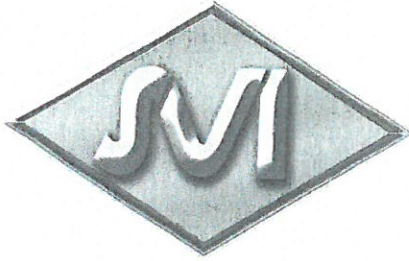

Specialty Vehicles, Inc.

www.svine.com



58 George Leven Drive
North Attleboro, MA 02760
Tel: 508.699.0616
Fax: 508.699.0977
Toll Free: 888.699.0616

PAYMENT TERMS

Full payment shall be made upon delivery and acceptance of the apparatus. The vehicle(s) shall not be released to the BUYER until payment is made. If the selling price is subject to any taxes, the taxes added will be that which are prevailing at the time of delivery.

Payment shall be made directly to FERRARA FIRE APPARATUS, INC. Payment shall be made in United States Currency. No checks or any other form of payment shall be made to any sales representatives, dealer, agents, etc.

If these payment terms are not strictly adhered to, Ferrara Fire Apparatus, Inc. shall assess a daily interest charge based on an annual percentage rate of 18% on the unpaid balance. If more than one vehicle is covered by this contract and the vehicles are shipped on different dates, the terms stated above shall apply to each vehicle.

SINGLE SOURCE MANUFACTURER

To provide the customer with a single point of contact for service, warranty, and parts, proposals shall only be accepted from manufacturers who assemble the complete apparatus in their own facility.

VIRTUAL MANUFACTURING

The manufacturer shall have a web site available for the customers to 'watch' their unit being produced. The "Trucks in Production" shall be updated a minimum of three-(3) times per week.

The web site shall also include documentation of cab and body crash tests, take a virtual tour of the production facility, videos of both current and new innovative products, updates on trade shows, photos of new deliveries and the opportunity to include customer 'Action Photo's'.

Customer shall be able to access the web site without the requirement of a password.

PRINCIPAL DIMENSIONS

The apparatus shall have the following dimensions:

Overall Length: 31' 1"

Overall Height: 9' 8-1/2"

Wheelbase: 186"

Cab to Axle: 126'

CERTIFIED WELDERS

The manufacturer shall employ individuals that are certified aluminum and stainless steel welders. The welders shall be certified by an outside testing laboratory. The certifications shall be available for viewing through the Human Resources office upon request.

BODY WEIGHT DOCUMENTATION

The manufacturer shall weigh each body prior to mounting on the chassis. The information shall be included in the documentation of the finished vehicle. Each body produced by the manufacturer shall be weighed, not just one body per model.

DRAWING, APPROVAL

Prior to construction, the successful bidder shall provide three-(3) approval drawings of the apparatus for the fire department's review. The drawings shall show such items as the chassis being utilized, lights, horns, sirens, pump panels, and all compartment locations and dimensions. The blueprint shall be a visual interpretation of the unit as it is to be constructed. The buying authority shall sign all drawings. One-(1) print shall be retained by the Fire Department, the dealer/sales representative shall retain one-(1) print, and one-(1) print shall be returned to the manufacturer.

TRANSPORTATION

To insure proper break-in of all components while still under warranty, the apparatus shall be delivered over the road under its own power (Rail and/or truck freight shall not be acceptable).

DELIVERY

The manufacturer will deliver the completed apparatus in one hundred twenty (120) calendar days receipt of the approved signed off pre construction changes.

The manufacturer shall not be held liable for changes arising from its failure to make or delay in making delivery because of fire, flood, strike, riot, chassis shortage, accidents, acts of God, or any circumstances beyond our control.

VEHICLE FAMILIARIZATION & DEMONSTRATION

Familiarization and demonstration of the vehicle shall be by a competent and qualified person as defined in the current standard of NFPA 1901 standard.

Familiarization of the vehicle shall include the following:

- How to locate gauges or indicators and check all fluid levels and operational issues of the vehicle
- How to tilt the chassis cab or hood assembly for access to the engine, fire pump, or aerial control, or any other device to allow access to fluids or for required maintenance
- Interior cab controls, instruments, mirrors, safety devices or alarms, brake operations, transmission control, pump controls, exhaust regeneration (if provided), seat adjustments, warning light engagement, and other operational equipment
- If the apparatus is provided with a fire pump system, the following minimum instructions:
 1. Setting of parking brake, proper transmission gear, and fire pump engagement operations
 2. Throttle control
 3. Primer and tank-to-pump operation
 4. Use of pressure control devices
 5. Tank refilling operations
 6. Proper operation of discharge controls
 7. Proper shutdown and draining of system

- 5) If the apparatus is provided with a generator, the following minimum instructions
 - a) Proper engagement if driven by the chassis
 - b) Startup, operation, and shutdown of generator
 - c) Monitoring of controls and instruments

- 6) If the apparatus is provided with a foam system, the following minimum instructions:
 - a) Startup, operation, and shutdown of foam system
 - b) Setting of foam percentages and other operational settings
 - c) Proper flushing and draining of the system

- 7) If the apparatus is provided with a water tower or aerial device, the following minimum instructions:
 - a) Positioning and locating the vehicle for safe operations
 - b) Chassis parking brakes and engagement of hydraulic system
 - c) Deployment of stabilization devices and use of ground pads
 - d) Operation of elevation, extension, and rotation of the aerial device
 - e) Operation of waterway, nozzle, and other firefighting devices of aerial device
 - f) Operation and use of breathing air system (if provided)
 - g) Specific aerial device maintenance and service areas for operators
 - h) Shutdown and return to service operations
 - i) Operation of tip controls and platform controls
 - j) General familiarization and demonstration of aerial device
 - k) Review of all safety devices, interlocks, and operational Hazards

MANUFACTURER SERVICE CONTACTS

The manufacturer must have a 24 hour/ 7 day a week, toll-free emergency hot line. The manufacturer must be capable of providing both in-house and on-site service for the apparatus. The service technicians shall be EVT certified in compliance with NFPA 1071 classifications F2 through F6. On-site service and maintenance shall be the primary function, to eliminate the vehicle having to leave the fire department jurisdiction. Copies of the certifications shall be made available through the Human Resources office.

SERVICE VEHICLES

The manufacturer shall have a minimum of 10 full time, company owned, service vehicles. The vehicles shall be available 24 hours a day, seven days a week to respond to customer needs. The Service Vehicles shall be operated by full time EVT Certified Technicians.

REPLACEMENT PARTS

Replacement parts shall be available directly from the manufacturer, as well as the dealer and or service centers.

NFPA 1901-2009

The National Fire Protection Association "Standard for Automotive Fire Apparatus, 2009 Edition, is hereby adopted and made a part of these specifications for the componentry supplied in the incomplete chassis.

CUSTOM FIRETRUCK CHASSIS

The chassis shall be designed and manufactured by a custom chassis manufacturer. The manufacturer shall demonstrate evidence of manufacturing similar custom vehicles for at least fifty (50) years.

The chassis shall be designed and manufactured for heavy duty fire service with adequate strength and capacity for all components as detailed within these specifications.

CHASSIS FRAME

The frame shall be designed to industry standards. The manufacturer shall provide a life time frame side rail warranty to the original purchaser of the chassis. The frame rails shall be 10.5" x 3.5" x .375" heat treated steel.

The frame side rails shall be 110,000 psi minimum yield and shall have a minimum section modulus of 18.34 cu. in. calculated by using the square corner shape method. The resulting frame rail resistance to bending moment shall be 2,017,400 in. lb. per rail.

To insure the maximum clamp load for the fastener prevailing torque the crossmembers shall be bolted in place using grade 8 bolts, hardened washers, and grade C distorted thread locknuts. Flanged head fasteners shall not be acceptable. The top of the frame rails shall be free of bolt heads.

Frame engine cutouts shall be made with a plasma torch to minimize the heat affected zone of the cut. All cutouts shall have a minimum of 6 inch transitions between rail flange cut depths to reduce the stress concentrations throughout the cutout area. The root of all transition areas shall have a minimum of a 2 inch radius to reduce stress concentrations at the root.

The frame rails shall be powder coated prior to chassis painting to reduce the effect of harsh road chemicals.

CHASSIS PAINT

The frame and running gear shall be painted gloss black enamel. The running gear shall consist of the axles, drivelines, air tanks, steering gear, frame mounted brackets, draglink(s), and fuel tank.

The air system piping and electrical harnesses shall not be installed in the frame at the time of the frame painting. This shall insure complete coverage of paint behind those areas, as well as to insure that the air piping and wiring harnesses do not have paint applied to them, hindering troubleshooting.

CAB MAIN FRAME CROSSMEMBER

In addition to the rear cab support crossmember there shall be a main frame cross member mounted in the rear cab area. This cross member shall be a wide base flanged design to provide frame spacing and excellent strength to prevent frame paralleling. Every frame cross member shall be bolted in place using grade 8 bolts, hardened washers, and grade "C" distorted thread locknuts.

FRAME WARRANTY

The frame and cross members shall carry a limited lifetime warranty to the original purchaser. The warranty shall include conditional items listed in the detailed warranty document which shall be provided upon request.

FRONT AXLE

The front axle shall be a MERITOR model "MFS-18-133A-N" with a 18,740 lb. capacity.

CRAMP ANGLE

The chassis shall have a turning cramp angle of 45-degrees. Both left and right turns have a full 45° cramp angle with tires and wheels mounted on the axle and installed in the chassis. The 45° cramp angle is achieved irrespective of options such as front suction and disc brakes.

FRONT AXLE OIL SEALS

The front axle shall be equipped with oil bath type oil seals as supplied on the axle from the axle manufacturer. The spindles shall be equipped with transparent covers for oil level inspection.

FRONT AXLE BRAKES

The front brakes shall be Cam-Master Q Plus, 16-1/2" X 6" (419 x 152), S-Cam, air operated heavy duty brakes for increased stopping power and brake life in severe braking applications.

The "S" cam brakes shall incorporate a double anchor pin design, for stability and smooth consistent stopping. The camshafts shall be heat treated with rolled spline construction.

The front axle shall be equipped with automatic slack adjusters (ASA) to provide optimum brake performance.

FRONT SUSPENSION

The front suspension shall be a pin and shackle design. Front springs shall be a minimum of ten (10) leaf elliptical type, 53" x 3-1/2" x .499" forged steel. The front springs shall have a military wrapper for safe operation. For a smooth ride the spring rate shall not exceed 3,000 lbs/in deflection.

All front spring pins shall be ground heat treated steel with grease fittings for lubrication.

The entire front suspension shall be designed for heavy duty custom fire apparatus with a capacity at ground of 18,740 lbs.

Double acting hydraulic shock absorbers are to be installed.

STEERING SYSTEM

The steering shall be equipped with a single SHEPPARD M110 integral power steering gear. The engine shall be equipped with a gear driven pump.

A remote steel reservoir shall be provided with the ability to check the fluid level when the cab is in the lowered position.

FRONT TIRES

The front tires shall be 315/80R22.5-20PR (L) GOODYEAR G-291 all weather tread, tubeless radial tires. These tires shall be mounted on 22.5" x 9.00" rims.

STANDARD LOAD RATING

The front axle GAWR using these tires shall be 18,180 lbs. @ 130 psi.

TIRE SPEED RATING

The maximum tire speed rating is 68 MPH.

FRONT STEEL RIMS

ACCURIDE, hub piloted, acrylic e-coat, painted steel disc wheels shall be supplied on the front axle.

SINGLE REAR AXLE

The rear axle shall be a MERITOR model "RS-24-160" with a 24,000# capacity for the fire service.

MERITOR DIFFERENTIAL

The rear axle shall contain a Meritor 160 Series differential with an 18 inch diameter ring gear utilizing hypoid-Generoid gearing and a 2-1/4 inch diameter axle shaft.

AXLE DIFFERENTIAL LUBE

The axle shall have the initial factory fill made with non-synthetic axle lube meeting the axle manufacturer's recommendations.

REAR AXLE OIL SEALS

The rear axle shall be equipped with premium oil bath type oil seals as supplied on the axle from the axle manufacturer.

REAR AXLE BRAKES

The rear brakes shall be Cam type, 16-1/2" X 7" (419 x 178), S-Cam, air operated heavy duty brakes for increased stopping power and brake life in severe braking applications.

The "S" cam brakes shall incorporate a double anchor pin design, for stability and smooth consistent stopping. The camshafts shall be heat treated with rolled spline construction.

The rear axle shall be equipped with automatic slack adjusters (ASA) to provide optimum brake performance.

VEHICLE TOP SPEED

The rear axle shall be geared for a top speed of 65 to 68 mph at engine governed RPM.

NFPA TOP SPEED STATEMENT

NFPA-1901, 2009 Edition - 4.15.2 The maximum top speed of fire apparatus with a GVWR over 26,000 lb (11,800 kg) shall not exceed either 68 MPH (105 km/hr) or the manufacturer's maximum fire service speed rating for the tires installed on the apparatus, whichever is lower.

NFPA-1901, 2009 Edition - 4.15.3 If the combined water tank and foam agent tank capacities on the fire apparatus exceed 1250 gal (4732 L), or the GVWR of the vehicle is over 50,000 lb (22,680 kg), the maximum top speed of the apparatus shall not exceed either 60 MPH (105 km/hr) or the manufacturer's maximum fire service speed rating for the tires installed on the apparatus, whichever is lower.

The speed selected on this apparatus exceeds 60 MPH (105 km/hr) and the customer is aware of NFPA-1901 and the top speed that will be achieved with the finished apparatus.

SINGLE AXLE REAR SUSPENSION

The rear springs shall be a minimum of seventeen (17) main including four (4) auxiliary leaves. The rear suspension shall have a rating of 27,000 lbs. Capacity. The rear suspension shall be a "self-leveling" slipper type with a main torque leaf that contains a military wrapper. The torque leaf shall contain a bronze bushing for long service life.

The rear hangers are to be of the slipper design. For a smooth ride the rear suspension deflection rate shall not exceed 3,790 lbs. per inch.

One (1) inch diameter rear suspension U-bolts are required.

Two (2) main frame cross members shall be mounted in the rear suspension area, bolted to the frame rail as a rear suspension support member. Each cross member shall be a wide base flanged design to provide frame spacing and excellent strength to prevent frame paralleling. Each cross member shall be bolted in place using grade 8 bolts, hardened washers, and grade "C" distorted thread locknuts.

AIR SYSTEM

An air brake system meeting the requirements of the FMVSS-121 shall be provided. The system shall consist of three (3) reservoirs with a 4,362 cu. in. volume. The air system shall consist of the following components:

Dual air system with dual gauges and a warning light and buzzer. A spring actuated parking brake built into the rear axle brakes with a manual control and warning light the in cab. These shall automatically apply in case of air system failure. A mechanical means of releasing the spring brake shall be provided in the event of total loss of air pressure.

A quick build up system shall be provided, capable of building enough air pressure to release the spring brake in less than thirty (30) seconds, when starting with the entire air system at zero pounds pressure.

The brake system shall be a split system. One (1) system serving the rear brakes and one (1) system serving the front brakes. The two (2) systems shall be connected with a double check valve that shall automatically shuttle air from the front system to the rear system should loss of air pressure occur. This system shall also modulate the amount of air so the spring brakes shall apply in direct relationship to the amount of pressure applied to the treadle valve.

The brake system shall be equipped with a Bendix SR-7 valve to provide modulated spring brakes in the event there is low air pressure in the rear axle air supply reservoir.

The spring brakes shall be piped in such a manner that if the treadle valve is depressed while the spring brakes are applied, the spring brakes shall release and remain released as long as the treadle valve is depressed. They shall reapply immediately when the treadle valve is released.

The piping in the air system shall be 2-ply nylon reinforced color coded tubing for all stationary lines.

AIR DRYER

The air system shall include a BENDIX AD-SP air dryer.

The air dryer shall have a spin off desiccant cartridge.

The air dryer shall incorporate an integral turbo cutoff valve. The turbo cutoff valve shall close the path between the air compressor and the air dryer purge valve during the compressor "unload" cycle. This shall allow the air dryer to purge the water and contaminants without any loss of turbo boost or engine horsepower.

A 12 volt heated moisture ejector shall be an integral part of the air dryer. This heater shall be thermostatically controlled. The electrical connection for the heater shall use a sealed electrical connector to protect against moisture and corrosion.

MANUAL AIR TANK DRAINS

All air reservoirs shall have manual 1/4 turn drain valves. The drain valves shall be supplied with rubber seats to reduce air system leaks. The reservoir drain valves shall allow the accumulation of contaminants that are collected in the reservoirs to be drained off to the atmosphere.

MERITOR/ROCKWELL/WABCO ABS BRAKE SYSTEM

A four channel, single rear axle model, MERITOR/ROCKWELL/WABCO ABS Braking System shall be supplied.

A frame mounted electronic control unit (ECU) shall monitor and control wheel speed during braking. Wheel sensors, constantly monitoring wheel speed, send information to the ECU. If a wheel begins to lock the ECU transmits an electrical impulse to modulator valves that can apply, release or hold the air pressure in the brake chambers. The rapid modulation of air pressure prevents wheel lock-up and increases driver control.

This ABS system shall be a 4S/4M system with four (4) wheel speed sensors and four (4) modulator valves.

If a fault occurs in one wheel, that wheel shall have normal (non-ABS) brake function. The other wheels shall continue to provide the ABS function. If the ABS system should fail completely, the brake control shall be returned to normal (non-ABS) braking.

An ABS warning light shall be installed on the driver's dash message center. This warning light shall cycle through a test stage at the point of ignition turn on and remain illuminated until the vehicle reaches approximately four (4) MPH. The light shall illuminate in other conditions to warn of an ABS system failure and shall illuminate when the diagnostic function is activated.

MERITOR/WABCO STABILITY ENHANCEMENT SYSTEM

A Meritor / Wabco Roll Stability Control (RSC) System shall be provided on the apparatus chassis. The RSC shall assist in managing road conditions that may result in a vehicle rollover.

The RSC shall intervene to regulate the vehicle's deceleration functions. by automatically reducing engine torque, engage the vehicle retarder and apply pressure to the brakes.

Electronic Stability Control (ESC) shall be included building upon the established RSC system by sensing the tendency of the vehicle to spin around and automatically applying the brakes to reduce that risk.

This system conforms to the requirements of NFPA-1901 4.13.1.2 - If the apparatus is equipped with a stability control system, the system shall have, at a minimum, a steering wheel position sensor, a vehicle yaw sensor, a lateral accelerometer, and individual wheel brake controls.

REAR TIRES

The rear tires shall be 11R22.5-16PR (H) GOODYEAR UNISTEEL G182 RSD traction tread, tubeless radial tires. These tires shall be mounted on 22.5" x 8.25" rims.

Single rear axle GAWR using these tires shall be 24,000 lbs. @ 120 psi.

TIRE SPEED RATING

The maximum tire speed rating is 75 MPH.

REAR STEEL RIMS

ACCURIDE, hub piloted, acrylic e-coat painted steel disc wheels shall be supplied on the rear axle.

LASER ALIGNMENT

The chassis shall have a laser alignment performed at the factory before delivery.

Toe In Front Axle - The toe in on a vehicle is set to reduce tire wear and to insure that the vehicle shall steer in a straight line. Toe in measurements are set to a positive 2.5 millimeters total, giving the vehicle 1.25 millimeters from side to side.

Toe In Rear Axle - The toe in on the rear wheels is set up slightly different in that the axle and wheels are set to ride the "crown" of the road. This is achieved by adjusting the toe to a measurement of no less than 1 millimeter, but no more than 2 millimeters. The ideal measurement is 1.5 millimeters total for both sides.

Cramp Angle - Cramp angle is set to achieve the greatest turning radius possible with the selected components of the vehicle. Each front wheel is set to zero degrees. The wheel is then turned until it reaches the steering stops. This measurement is the cramp angle.

TIRE PRESSURE MONITORING DEVICE

Each tire installed on the apparatus shall be equipped with a tire pressure monitoring device. The device shall consist of a valve stem cap to with an LED tire alert to indicate tire pressure conditions. The LED will flash when the tire drops 8 psi below the factory setting.

DIESEL ENGINE

The chassis shall be powered by a Cummins diesel engine as described below:

MODEL:	ISL9-330
NUMBER OF CYLINDERS:	Six
BORE AND STROKE:	4.49 in (114 mm) x 5.69 in (145mm)
DISPLACEMENT:	543 cu. in. (8.9L)
RATED BHP:	330 hp (246kW) @ 2000 RPM
TORQUE:	1000 lb-ft (1357 N-m) @ 1400 RPM
COMPRESSION RATIO:	16.6:1
GOVERNED RPM:	2200

Standard Equipment on the engine to include the following:

OIL FILTER: A full flow / by-pass combination

LUBE OIL COOLER:	High efficiency non-drainback full flow cooling
FUEL FILTER:	One fuel filter providing 10 micron absolute filtration
STARTER:	12 volt
AIR COMPRESSOR:	A Wabco 18.7 cfm compressor shall be provided

ENGINE COOLANT RADIATOR

The engine coolant radiator shall have sufficient capacity to perform under the engine manufacturer installation requirements. The chassis manufacturer shall demonstrate the ability to meet this requirement with the submittal of an approved IQA to the fire department for the apparatus.

The engine coolant radiator shall have a minimum core area of 989 square inches.

This radiator shall have drawn steel top and bottom tanks. These tanks shall have a material thickness of 16 gauge.

The tanks shall be bolted to the radiator header assemblies.

The header plates shall be made of 16 gauge brass.

The radiator tubes shall be constructed of .0068 inch thick brass and have a dimensional size of .076 inch x .625 inch. These radiator tubes shall have welded tube seams.

The radiator shall contain four (4) rows of tubes arranged in an inline profile across the radiator core. The entire radiator shall contain (184) tubes. These tubes shall have a smooth bore to allow for radiator cleaning.

In the critically stressed area, where the radiator tubes are attached to the header plates, this joint shall be accomplished with a welding process on the coolant side. In addition to the welded joint a solder fillet joint shall occur on the air side of the core creating a continuous dual bond.

The radiator shall have a louvered serpentine type core that contains fins constructed of .003 inch thick copper. These fins shall be spaced to a maximum density of 14 fins per inch of radiator tube. Each fin shall have a louvered surface for high cooling efficiency.

The radiator shall contain an integral coolant de-aeration tank. This tank shall be designed to remove entrapped air or gas from the coolant side of the radiator.

The bottom tank of the radiator shall have a drain valve for coolant removal.

The bottom tank of the radiator shall have a transmission cooler with a plate-type design. The plates shall have internal turbulators to break up laminar oil flow across the surface. The cooler shall have 1175 square inches of surface area for water surface contact and heat transfer.

All radiator hoses shall be attached to the cooling system with stainless steel worm drive clamps.

The radiator system shall be pressurized with a cap rated per the cooling system requirements of the specific engine manufacturer.

The high efficiency engine fan shall be encompassed with a radiator shroud to provide the proper air flow from the fan blade to the radiator.

The radiator shall have recirculation baffles to eliminate the possibility of recirculation of "hot" air to the face of the radiator core. The bottom of the radiator shall have a recirculation baffle from the radiator to the frame rails.

COOLANT RECOVERY SYSTEM

A coolant recovery system shall be installed on the chassis. This tank is designed to capture coolant overflow when the engine coolant warms and expands. As the engine cools the overflow is then pulled out of the tank and back into the radiator, thus maintaining proper coolant levels.

CHARGE AIR COOLER RADIATOR

The engine charge-air cooler shall have sufficient capacity to perform under the engine manufacturers installation requirements. The chassis manufacturer shall demonstrate the ability to meet this requirement with the submittal of an approved EPQ to the fire department for the apparatus.

This radiator shall have cast aluminum side tanks. These tanks shall have a material thickness of .200. These tanks shall be attached to the charge-air core with the ALBRAZE construction technique.

The external air fins shall be louvered serpentine and constructed of .006 inch thick aluminum.

The internal air fins shall be of the lance-and-offset design for greater air turbulence and higher efficiency. The internal fins are to be constructed of .010 inch thick aluminum.

The charge-air cooler shall be mounted directly in front of the engine coolant radiator. To reduce vibration rubber "iso" mounts shall be used for mounting of the charge-air cooler to the engine radiator.

The charge air cooler shall contain (12) rows of internal fins within a .313 x 2.632 aluminum tube assembly. This tube assembly shall be constructed of .025 thick aluminum.

The charge-air cooler shall contain thermal expansion slots to allow the expansion and contraction of the charge-air core over the wide range of temperatures that are expected in operation.

The charge air piping between the engine and charge-air cooler shall be aluminum tubing with a wall thickness of .065 inch. The system shall utilize four (4) ply silicone rubber woven Nomex hoses with stainless steel pressure bands. These bands are designed to maintain the hose shape under the pressure of the turbocharger boost air. All clamps used on the charge air piping are to be stainless steel constant torque and shall be installed at each joint.

COOLANT

The coolant system shall contain an ethylene glycol and water mixture to keep the coolant from freezing to a temperature of -34 degrees F.

COOLANT HOSES

The entire chassis cooling system shall have premium rubber hoses. All clamps to be stainless steel worm drive type clamps.

HEATER LINE SHUT OFF VALVES

The heater circuit shall have quarter turn shut off valves installed on both the supply and return lines to allow a complete shut off of coolant flow to the cab heaters in hot seasons of the year. These valves shall be installed in addition to the valves in the heater unit(s).

ENGINE AIR INTAKE FILTER

The engine shall be equipped with a K&N heavy duty washable intake air filter. The filter shall utilize a media that does not require oil.

ENGINE OIL

The engine shall have the initial factory fill made with a non-synthetic engine oil meeting the engine manufacturer's recommendations.

ENGINE BRAKE

A "JACOBS" Engine Brake shall be supplied.

The Driver's dash shall include an engine brake control switch.

Activation of the engine brake shall occur at zero throttle position. The transmission ECU shall be programmed to operate in the pre-select downshift mode to maximize the retarding power of the engine brake.

The brake lights shall illuminate when the Jacobs Brake is in operation.

The Jacobs Brake shall be inoperative when the chassis is in pump mode.

The "JACOBS" engine brake shall be covered under the standard five year Cummins engine warranty.
ENGINE FAST (HIGH) IDLE

The chassis shall be equipped with an Electronic Idle Control (EIC) for the electronic engine. Preset speed is factory adjustable.

The fast idle provision shall only function when the parking brake is set and the transmission is in neutral. Manual selection of the fast idle shall be controlled by a driver's momentary switch.

Automatic activation of the fast idle shall occur when a low voltage condition exists, the truck is in neutral and the parking brakes are applied.

Cancellation of the fast idle shall be achieved by resetting the manual switch or by depressing the service brake pedal.

CORROSION INHIBITOR

Corrosion inhibitor shall be provided as an additive to the chassis cooling system.

AUXILIARY ENGINE COOLER

The cooling system shall have one (1) SENDURE auxiliary engine cooler mounted in the upper radiator water pipe. The apparatus shall have the fire pump water circulated to the cooler from a valve located on the apparatus pump panel.

SPARK ARRESTOR

A spark arrestor shall be installed in the chassis air intake system. This arrestor shall be mounted behind the intake grille to filter out airborne embers.

HORTON FAN

A fan clutch shall be installed on the engine. A manual switch shall be provided in the dash, to over ride the fan control in event of fan failure or conditions that may result in overheating of the engine.

EXHAUST SYSTEM

A single exhaust pipe shall be provided for the engine. The exhaust pipe shall be supplied with a heat wrap. The wrap shall extend from the engine turbo charger to just below the frame rail.

The exhaust tubing from the turbocharger to the exhaust after treatment device shall be stainless steel.

CUMMINS AFTERTREATMENT SYSTEM

The chassis shall be equipped with a Cummins exhaust after treatment system in compliance with EPA 2010.

TAILPIPE

The tailpipe shall extend from the exhaust muffler/aftertreatment device to the rear of the vehicle making a 90° bend to exit the vehicle ahead of the rear tires on the curbside of the vehicle. The end of the pipe shall be cut square or perpendicular to the exhaust pipe centerline.

The pipe shall be unpolished stainless steel.

An exhaust gas diffuser shall be furnished on the end of the tailpipe.

DIESEL EXHAUST FLUID SYSTEM

The chassis shall be equipped with a 5 gallon Shaw Development Diesel Exhaust Fluid (DEF) reservoir system. The reservoir shall contain an Multifunctional Head Unit (MFHU) that contains integrated level and temperature sensors. The MFHU also shall contain a coolant powered heater to thaw DEF in conditions below 12°F (-11°C) to meet governmental regulations. The reservoir shall be located on the left frame rail behind the front axle beneath the cab. The mounting system shall use stainless steel mounting brackets to reduce the possibility of corrosion.

TRANSMISSION

The transmission shall be an Allison 3000EVS automatic transmission with electronic controls.

The transmission shall be equipped with a lock-up control circuit that shall automatically shift the transmission into 4th gear lock-up when the pump is shifted into gear.

TRANSMISSION COOLER

An automatic transmission cooler shall be provided as an integral part located in the bottom tank of the radiator. It shall be designed to withstand 165 psi working pressure and an intermittent pressure of 250 psi. The cooler shall be of sufficient size to maintain the operating temperature within the recommended limits of the transmission manufacturer.

TRANSMISSION FLUID

The transmission shall be provided with heavy-duty transmission fluid meeting Allison specification TES-389.

FIVE SPEED PROGRAMMING

The transmission shall be programmed for five speeds.

First - 3.49
Second - 1.86
Third - 1.41
Fourth - 1.00
Fifth - 0.75
Reverse - 5.03

The transmission shall be able to shift from first through fifth gear without operator intervention. The chassis shall be geared for the top speed in 5th gear.

AUTOMATIC NEUTRAL

The transmission shall be provided with circuitry to provide automatic neutral. Setting the parking brake commands the transmission to neutral when the park brake is applied, regardless of drive range requested on the shift selector. Requires re-selecting drive range to shift out of neutral.

After the transmission has been activated with the automatic neutral feature the shift lever must be returned to neutral and back to drive for midship pump operations.

REMOTE FLUID LEVEL SENSING

The chassis shall be equipped with an electronic low fluid level indicator system for the engine oil, transmission oil, engine coolant and power steering fluid as part of the instrumentation package. This system eliminates the need for daily checking of fluid levels with manual dipsticks.

Coolant over temperature sensors are only capable of sensing excessive coolant temperature caused by clogged radiators, malfunctioning thermostats, failed water pumps or any other "circulation" problem. Upon loss of coolant, however, these temperature sensors must try to respond to hot air which, being a poor thermal conductor, results in signals that arrive only after the engine is severely damaged.

In a like manner, under leaking oil conditions low oil pressure signals are not obtained until the oil pump is starved for oil. Since the oil pump draws liquid from the very bottom of the crankcase pan, these signals arrive only after virtually all oil has been lost. Again, the damage has already occurred.

The liquid level sensor provides an early warning that fluid is being lost and allows corrective action to be taken before damage can occur. By using a sensor to turn on an indicator light, the low fluid level condition is communicated immediately to the operator.

ENGINE COOLANT

The coolant level sensor is located in the upper radiator reservoir. The corresponding LED indicator light is included in the display module.

ENGINE OIL

The engine oil sensor is in the engine oil sump. It monitors the oil level at approximately the 50% level. The corresponding LED indicator light is located to the right of the instrument panel on the doghouse in clear view of the driver.

POWER STEERING FLUID

The power steering fluid sensor is located in the power steering fluid reservoir at the same level as the "Add" indicator on the dip stick. The corresponding LED indicator light is located to the right of the instrument panel on the doghouse in clear view of the driver.

FUNCTION

The LED indicator lights will illuminate when the ignition is placed in the ON position as a test to insure that the warning circuits are working. They will go out when the starter button is pressed if normal fluid levels are detected. One or more of the lights staying on indicates a low fluid level in the corresponding system(s). Any time the engine is ON and a low fluid level is detected, the appropriate light will illuminate. The sensor output will reset when the ignition is turned off.

TRANSMISSION OIL

The transmission oil sensor is in the transmission oil sump. The fluid level indicator is integrated into the shift selector. Accessing the fluid level status is dependent upon the style of shift selector provided.

The transmission fluid level status is accessed through the "mode" function of the shift selector controls. First, park the vehicle on a level surface, shift to N (Neutral), and apply the parking brake. If equipped with a pushbutton shift selector, simultaneously press the Up and Down arrow buttons. If equipped with a lever shift selector, press the display mode button one time. A code will be displayed on the shift controls indicating that the oil level is HI, LO or OK. If the level is HI or LO, the display will also indicate the number of quarts of oil necessary to be added or removed to bring the oil level into the OK range. It may also display an error code that explains why fluid level information is not available. The fluid level check may be delayed until the following conditions are met:

- The fluid temperature is above 60°C (140°F) and below 104°C (220°F).
- The transmission is in N (Neutral).
- The engine is at idle

- The transmission output shaft is stopped.
- The vehicle has been stationary for approximately two minutes to allow the fluid to settle.

See the Care and Maintenance section of the transmission Owner's Manual for a more detailed description of the fluid check procedure along with a complete list of error codes.

DRIVELINES

Universal joints and driveshafts shall be SPICER 1710 series or equal. The driveshaft tube shall be a minimum of 4.0" diameter with a .134" tube wall thickness. The driveshaft slip joints shall be coated to reduce sliding friction and thrust under high torque loads. Permanent driveline installations shall be balanced to prevent vibration.

TEMPORARY DRIVELINE INSTALLATION

The drivelines and driveline center bearing supports shall be a temporary installation for completion by the apparatus manufacturer.

FUEL TANK

The fuel tank shall have a capacity of 50 gallons (US) and be D.O.T. certified. It shall be mounted with straps bolted to the bottom frame flange to allow for easy removal. The tank construction shall be of 12 gauge steel with single fuel pickup and return tubes. The baffled tank shall be vented to prevent low vacuum and facilitate rapid filling.

The tank shall have a 2" NPT fill to the driver's side of the chassis.

The fuel tank sending unit is to be mounted to the driver's side of the fuel tank for easy replacement without removing body panels.

FUEL LINES

Polyamide fiber, nylon braided, reinforced tubing with push-on reusable fittings shall be provided for the chassis fuel lines.

FUEL/WATER SEPARATOR

The Cummins engine shall be equipped with an integrated fuel / water separator with a self venting bottom drain valve. This filter shall be able to remove up to 95% of dissolved water and up to 99% of free standing water.

ALTERNATOR

A LEECE-NEVILLE model LN4867J 270 Amp alternator shall be installed on the engine. This alternator is internally rectified and regulated.

FIRETRUCK CAB

The apparatus shall be designed to operate in emergency conditions. These conditions require the apparatus to maneuver into areas at a high rate of speed. To facilitate in these operations a cab-over-engine design is required in order to reduce the overall length of the apparatus thus increasing the maneuverability.

The cab design must be such to provide safe and efficient transport of emergency personnel. The cabin shall be designed with four (4) side doors of the largest size possible and with a grab handle and step arrangement to provide ease of entry and egress.

There shall be up to six (6) positions available for occupant transport with a minimum of four (4) forward facing seating positions in the cab. The number of seats and seating locations are described in detail later in this document.

The apparatus cab shall be of the latest in automotive design, styling and appearance.

CAB MATERIALS AND CONSTRUCTION

The extruded aluminum x/ cab shall have the following material gauges as a minimum:

- Cab floor - 3/16" (.190") aluminum
- Front skin - 3/16" (.190") aluminum
- Cab side panels - 3/16" (.190") aluminum
- Cab rear wall - 3/16" (.190") aluminum
- Cab driver's floor - 3/16" (.190") aluminum
- Cab officer's floor - 3/16" (.190") aluminum
- Cab crew area floor - 3/16" (.190") aluminum
- Cab roof - 3/16" (.190") aluminum
- Cab doors - 3/16" (.190") aluminum

Roof Rail Section Extending from the front to the rear of the cab above the doors the cab shall have and extruded aluminum section. This section shall be designed to interlock with the roof sheet and incorporate the door drip molding in one single piece.

Upper Transverse Member Amid ship in the cab there shall be a boxed beam header assembly located transverse in the cab from left to right.

Front Door B-Post This vertical box section of the cab located behind each of the front doors provides the slam post for the door latch assembly. This section also is a main member in the cab skeletal system. The B-Post ties into the Upper Transverse Member to provide torsional stiffness in the open space design of the cab.

Rear Door B-Post The box assembly design of the rear door B-post provides an anchor for the rear door latch assembly. This section is the main vertical support at the cab rear corner providing the anchor point for the rear wall structural lattice network.

Roof Panel Rails - The roof panel sub-assembly shall have extruded hat section supports bonded to the roof skin. These roof hat sections shall be joined to the Cab Roof Rail Section to complete the upper cab skeletal structure. These completed Roof Panel Rails shall provide a grid for maximum roof crush and deflection strength. The roof shall support a minimum weight of 250 lbs. / sq. ft. without permanent roof deformation.

Rear Wall Rails - The rear wall assembly shall have extruded hat section supports bonded to the wall skin. These sections shall be joined to the Roof Panel Rails and to the rear door slam post and floor provide a rear wall grid structure with maximum strength.

Cab Front Wall - The front wall of the cab shall be designed with a double wall construction to reduce the effects of exterior noise in the crew and operator compartment.

CAB DIMENSIONS

The cab shall have the following overall dimensional requirements:

- Overall Width - 100 inches
- Roof - 12" Extended Forward Raised
- Center of front axle to back of cab - 60 inches
- Center of front axle to front of cab - 74 inches
- Windshield area - 4,200 sq. in. minimum
- Front grille opening - 470 sq. in. minimum
- Combined side grille opening - 84 sq. in. each minimum
- Cab full tilt angle - 45 degrees minimum
- Cab full tilt height - 185 inches maximum

Cab interior dimensions shall be provided as a minimum in the following chart:

- Drivers side floor width 25-1/2 inches minimum
- Floor to the ceiling in the driver and officers area of the cab 59-1/2 inches minimum
- Floor to the top of the doghouse 28-1/2 inches maximum
- Officers side floor width 24-1/2 inches minimum
- The measurement across the floor from the rear wall to the first vertical portion of the engine enclosure 39 inches
- Floor to the ceiling in the rear of the cab 65-3/4 inches minimum

CAB DOORS

The cab entry and egress shall be designed for a firefighter in full turnout gear. Each door shall open a minimum of ninety degrees to afford the firefighter maximum space.

The doors shall be of a flush design each having exposed, one-piece, polished stainless steel hinges. The hinge shall be made of 12-gauge material with a minimum hinge pin diameter of 1/4 inch.

The door windows shall have interior and exterior glass weather seals to prevent the influx of exterior air.

The doors shall have exterior and interior paddle type latches for ease of opening with a gloved hand. The paddle latches are to have a rubber gasket, on the outside, separating the handle from the finished painted surface.

FRONT DOORS

The cab front doors shall be of the full-length design enclosing the entire step area of the cab. The door shall be a minimum of 38-1/2 inches wide and 74 inches tall. The front door windows shall have a minimum of 712 square inch area of viewing glass per door. There shall be a fixed piece of forward glass in each of the front doors.

REAR CAB DOORS

The rear cab doors shall be similar to the forward doors and shall be located directly behind the front wheel well area. These doors shall be 86 inches high x 34 inches wide. Each door shall have a roll down rear window with a minimum glass viewing area of 670 square inches.

INTERIOR DOOR LOCKS

All doors shall have door locks with interior controls and exterior keyed door locks. The installation shall be in conformance with FMVSS 206, with specific adherence to 49 CFR 571.206 Section 4.1.3 requiring that "Each door shall be equipped with a locking mechanism with an operating means in the interior of the vehicle". All doors shall be keyed alike. The doors shall be equipped with appropriate safety interlocks to prevent accidental locking of the doors when closed.

CAB GLASS

All glass shall be tinted.

All fixed glass shall be installed with a one-piece triple locked rubber lacing material. Due to long term appearance two-piece chrome trim lock lacing is not desired.

SUNVISORS

The driver and officer side of the cab shall be equipped with a sun visor. The vinyl covered visors shall be a minimum of 17-1/2" by 9".

DRIVER SIDE ELECTRICAL CABINET

Beneath the drivers seat there shall be an electrical cabinet designed to house the main battery electrical disconnect and facilitate the installation of an onboard battery charger or battery conditioner. A bolt on limited access; aluminum diamond plate hatch shall be installed on the front side of the seat box. The access hatch shall have a louvered section to provide air circulation to the cabinet. This cabinet shall not be used for casual storage.

WINDSHIELD WIPERS

Two speed electric pantograph wipers shall be installed. These wipers shall have minimum 24" blades and have 28 1/2" wet arm electric pump washers. A 70 oz. Minimum windshield washer reservoir shall be furnished.

STEERING WHEEL AND COLUMN

The steering column shall be a DOUGLAS tilt / telescopic type with an integral high beam / turn signal control switch. The column shall have self-canceling design for the turn signal switch. A 4-way warning "Hazard" light switch shall be mounted on the column. For safety, a rubber boot shall be installed to cover the steering shaft from the dash to the floor.

The steering wheel shall be a minimum of 18-inch diameter, covered with a padded absorbite finish. A lever on the left side of the steering column shall control the telescopic feature of the steering column.

FASTENERS

All cab exterior fasteners shall be stainless steel type fastened to the cab with nutserts.

BATTERY ACCESS

The rear cab steps shall have a removable kick panel, providing access to the batteries for routine maintenance and inspection.

TRANSMISSION RANGE SELECTOR

The transmission shall be controlled by an electro-mechanical lever type shift control. It shall be internally illuminated for night operation and have an internal lock (hold override button) to securely hold the shifter in the position selected.

TRANSMISSION OIL LEVEL SENSOR

The transmission shall be equipped with the oil level sensor (OLS). This sensor shall allow the operator to obtain an indication of the fluid level from the shift selector. The sensor display shall provide the following checks, correct fluid level, low fluid level and high fluid level.

EMI/RFI PROTECTION

The apparatus shall incorporate the latest designs in the electrical system with state of the art components to insure that radiated and conducted electromagnetic interference (EMI) and radio frequency interference (RFI) emissions are suppressed at the source.

The apparatus proposed shall have the ability to operate in the environment typically found in fire ground operations with no adverse effects from EMI/RFI.

EMI/RFI susceptibility is controlled by utilizing components that are fully protected and wiring that utilizes shielding and loop back grounds where required. The apparatus shall be bonded through wire braided ground straps. Relays and solenoids that are suspect to generating spurious electromagnetic radiation are diode protected to prevent transient voltage spikes.

In order to fully prevent the radio frequency interference the purchaser shall be requested to provide a listing of the type, power output, and frequencies of all radio and bio medical equipment that is proposed to be used on the apparatus.

BATTERY BOX TRAY - STAINLESS STEEL

The battery box trays shall be stainless steel to reduce the corrosive potential of the tray. The battery hold down and brackets and hardware shall also be made of stainless steel.

BATTERY BANK

A single battery system shall be provided, utilizing three (3) high cycle type Group 31 batteries.

This system shall be capable of engine start after sustaining a continuous 150 amp load for 10 minutes with the engine off (NFPA-1901).

A battery disconnect switch (Rated at not less than 450 amps continuous) shall be used to activate the system and provide power to the power panel. A green pilot light shall illuminate to indicate that the battery bank is activated.

BATTERY CABLES

All battery wiring shall be "GXL" battery cable capable of handling 125% of the actual load. It shall be run through a heat resistant flexible nylon "HTZL" loom rated at a minimum of 300 degrees Fahrenheit. All cable connections shall be machine crimped and soldered.

STARTING CIRCUIT

One (1) engine start button is to be located on the lower right dash panel. It shall be wired to heavy duty solenoid rated at not less than 1100 amps. The battery indicator light is to be located directly above the start button to indicate that the battery bank is on.

ENGINE DOGHOUSE

The engine doghouse inside the cab will be padded with a layer of sound and heat absorbing foam and covered with heavy duty vinyl trim upholstery to match or accent the interior of the cab.

The underside of the engine enclosure shall be covered with a sandwiched material for interior cab noise and heat rejection. This sandwiched acoustical material shall have one layer of 1/8" foam, a 3/16" single barrier septum and a 7/8" layer of foam to provide an overall thickness of 1-3/16". The sandwich material shall be chemically bonded to prevent layer separation. A finished surface treatment of metalized film shall be provided on the engine side of the barrier. The acoustical barrier shall be held in place with mechanical fasteners in addition to adhesive.

The insulation for protection from heat and sound shall keep the dBa level within the limits stated in the current edition of NFPA 1901.

CAB DOORS - INTERIOR TRIM

To provided durability the interior of the cab doors shall be finished with full length aluminum panel that is finished with Zolatone high abuse paint.

INTERIOR CEILING PADDING AND TRIM

The cab front interior ceiling shall have a one-piece, removable, vinyl headliner to cover all wiring and tubing used for lights and antenna leads.

REAR WALL COVERING

The rear interior wall of the cab shall have a two-piece, removable, wall covering to finish the interior trim, cover all wiring and tubing used for lights and antenna leads.

FLOOR COVERING

The front and rear floor areas of the cab shall be covered with "HUSHCLOTH" sound barrier floormats. This floormat shall be a three ply material with a 3/16" thick open cell isolation barrier of Polyurethane, a 3/32" thick closed cell Nitrile mid barrier for section reinforcement, and a 1/16" thick embedded pebbled grain wear surface.

REAR FACING SEAT BOX COVERING

The rear facing seat box area of the cab shall be covered with "HUSHCLOTH" sound barrier floormat. This floormat shall be a three ply material with a 3/16" thick open cell isolation barrier of Polyurethane, a 3/32" thick closed cell Nitrile mid barrier for section reinforcement, and a 1/16" thick embedded pebbled grain wear surface. The seat box covering shall blend with the cab interior paint color.

INTERIOR CAB STEP TRIM

The cab steps shall be completely enclosed behind each door. The top surface of the steps shall be covered with non-skid aluminum treadplate trim.

RADIO COMPARTMENT

Beneath the officer's seat there shall be a radio compartment with an interior dimensions of 19-1/2" wide x 17" long x 7" high.

CAB STEP DIMENSIONS

The front cab steps shall have the following overall dimensional requirements:

- Driver's lower step size 10-1/4 inches deep minimum
- Driver's lower step size 29-1/2 inches front to back

- Officer's lower step size 10-1/4 inches deep minimum
- Officer's lower step size 29-1/2 inches front to back

INTERMEDIATE CAB STEP

The cab shall have a full width intermediate "LaserGrip" anti slip inside step. The intermediate step shall be approximately 9 inches from the top of the lower step to the top of the intermediate step.

INTERIOR CAB STEP TRIM

The cab steps shall be completely enclosed behind each door. No portion of the cab entrance step shall be exposed when the door is in the closed position. The lower step shall be sealed from the underside of the cab to eliminate road splash from entering the step area while the vehicle is driving. The horizontal step surfaces shall be covered with bright aluminum tread plate meeting the requirements of NFPA-1901.

The vertical toe kick surface area of the cab step wells shall be covered with aluminum tread plate.

COMPARTMENT OPEN LIGHT

A Red Open Compartment Flashing Light, Whelen OS Series LED shall be mounted on the driver's side face of the overhead panel. A chrome flange is to be supplied with the light.

This light is wired with a flasher to the power panel for completion to circuit on the body.

The light circuit shall be wired so that the light circuit is deactivated when the parking brakes of the apparatus are applied.

A label shall be applied adjacent to the light '**DOOR OPEN**'.

Interior Lighting Group - Ferrara

LED WHITE DOME LIGHTS

Four (4) 6" diameter white LED interior dome lights shall be provided. Each light shall be surface mounted and draw 0.65 amps at 12 volts. The lamp shall have high output white LED's with a light output of 700 lumens. The light shall be rated for 50,000 hours and have a Lifetime Limited Warranty.

Two (2) lights shall be installed in the front of the cab, one each adjacent to the driver and officer. Two (2) lights shall be installed in the rear crew area and all white lights and shall be operated by opening any cab door.

STEP WELL LIGHTING

Four (4) step well lights shall be supplied. The lights shall be Whelen OS Series white LEDs with angled chrome plated covers, one in each step well. All step well lights shall be illuminated when any door is opened and the battery selector switch is on.

HEATER / DEFROSTER

A 57,600 BTU heater with a three speed fan shall be mounted in the front of the cab, centered over the windshield. This heater shall have six (6) adjustable vents to assure windshield defogging.

45,000 BTU AIR CONDITIONING

A climate control system shall be furnished in the cab. The system shall consist of a 45,000 BTU air conditioning evaporator centrally located on the rear of the engine doghouse.

The system is to have a 12.6 cu. in. minimum compressor mounted on the engine to provide the compressed refrigerant to the system. The compressor is to be plumbed to a heavy duty truck, triple fan air conditioning condenser mounted on the cab roof. The condensing unit shall have an aerodynamic shroud that is painted to match the color of the cab roof. There shall be an extended life filter receiver/dryer with a pressure relief valve installed to protect the system from contaminants, moisture, and high pressure. It is to have a sight glass for visual inspection and ease of service.

The evaporator shall have an externally equalized expansion valve and be thermostatically protected to prevent freeze up. Dual high performance 3-speed blowers shall provide a minimum of 700 CFM air flow. Each blower is to be controlled separately. Four (4) forward facing and three (3) rear facing full adjustable diffusers with shutoff capability shall be utilized to direct the air flow through the cab.

The air conditioning on/off switch, thermostat control, and blower switches shall be located on the evaporator unit.

The air conditioning system shall use R134A freon.

36,000 BTU SUPPLEMENTAL HEATER

A 36,000 BTU auxiliary heater shall be furnished inside the conditioning evaporator unit to provide additional cab heating during cooler weather. The heater core is to be plumbed to the water lines of the engine cooling system.

CAB INSULATION

Foam rubber type insulation shall be installed in the rear wall and the cab ceiling to provide a better sound and heat barrier. The insulation shall be a minimum of 1" thick. The material shall be compliant with FMVSS-302.

DRIVER INSTRUMENTATION AND CONTROLS

The gauges shall have red LED back lighting for enhanced visibility. Upon an initial ignition sequence a lamp check function shall illuminate the warning light telltales, the self diagnostic message center shall sequence the warning light telltales if data link communications are lost. The instrument panel shall include the following gauges and indicators.

Electronic speedometer with LCD odometer

Tri cluster gauge that includes:

- Electronic tachometer
- Engine coolant temperature gauge, with warning light and buzzer
- Engine oil pressure gauge, with warning light and buzzer
- Transmission fluid temperature gauge, with warning light and buzzer
- Two air pressure gauges, with warning light and buzzer
- Voltmeter, with low voltage warning light and buzzer
- Fuel level gauge

- High beam indicator light
- Parking brake set light
- Turn signal indicator lights

The lighting control panel is to be located to the left side of the instrument panel. The lighting control panel shall include the following:

- Headlight control switch
- Dash rheostat for instrumentation lighting control
- Wiper and washer control switches

The engine control panel is to be located beneath the instrument panel on the driver's right hand side. The engine control panel shall include the following:

- Keyless ignition switch with a green pilot light

The apparatus control panel is located beneath the instrument panel on the driver's left hand side. The apparatus control panel is designed for the location of pump shift controls.

AUDIBLE TURN SIGNAL REMINDER

There shall be an audible alarm that shall sound when the turn signal remains flashing for a distance greater than one mile. The reminder shall not sound when the hazard lights are operating.

AUDIBLE LIGHTS ON REMINDER

There shall be an audible alarm that shall sound when the headlight switch is left in the on position and the ignition is off. The alarm shall self cancel after 2 minutes of operation.

AUDIBLE PARKING BRAKE REMINDER

There shall be an audible alarm that shall sound when the parking brakes are NOT set and the ignition is turned off. This alarm shall self cancel after 2 minutes.

The Parking Brake reminder shall sound an audible alarm when the parking brakes are set and an indicated speed of over two miles per hour occurs.

DUAL TRIP ODMETERS

There shall be two (2) trip odometers in the driver's information center. Each shall be capable of independent operation and reset. They shall be labeled Trip1 and Trip2 when the trip mileage is shown in the LCD panel.

SPEEDOMETER ACTIVATED IN PUMP MODE

The speedometer and odometer shall be activated while in pumping mode.

LOW FUEL LIGHT

A "Low Fuel" warning light and alarm shall be installed in the dash message center. This light shall illuminate when the apparatus fuel level reaches 25% of the fuel remaining.

TRANSMISSION OVERHEAT WARNING LIGHT

A transmission oil temperature light with alarm shall be provided on the dash message center.

LOW VOLTAGE WARNING

A low voltage indicator light shall be installed on the dash message center. An alarm and the dash indicator light shall activate when the system voltage drops below 11.8 volts.

AIR CLEANER RESTRICTION INDICATOR

An air cleaner restriction indicator shall be installed in the driver's message center. The indicator shall provide visual warning when a high air restriction condition exists for a minimum of 4 seconds.

LOW COOLANT WARNING

Low coolant warning shall be accomplished through the engine electronics to provide driver warning via the engine stop warning light.

INTERMITTENT WIPER CONTROL

A rotary combination intermittent electric wiper / washer switch shall be provided on the left hand side of the driver's dash.

CONTROL CENTER

Mounted on the doghouse there shall be a driver / officer control center. This area shall include various controls and functions that must be available to the driver and officer.

The apparatus warning light switch panel shall be mounted on the control center immediately to right of the driver. The panel will have a black anti-glare surface, and within easy reach of the driver. The panel shall include one (1) lighted master control switch to allow for preselection of the other switches and thirteen (13) lighted individual lighting control and chassis option switches.

Each switch shall have back-lit legends with a 100,000 hour lamp for illumination.

The master lighting control switch shall be wired to three (3) 30 amp circuit breakers and three (3) 40 amp relays. Three (3) 10 gauge wires are powered by this circuit and run to the roof for light bar power. The remaining switches shall be wired to 20 amp circuit breakers and relays.

PARKING BRAKE CONTROL VALVE

The parking brake control valve shall be located in the driver's dash engine control panel.

CUP HOLDERS

There shall be two (2) recess mounted cup holders mounted on top of the doghouse console.

CHASSIS ELECTRICAL SYSTEM

The apparatus "Electrical Distribution System" (EDS) shall be mounted inside the cab to prevent moisture from entering the area. It shall be mounted under the dash on the officer's side behind a diamond plate cover.

The EDS shall be fed by one power stud:

One (1) battery positive

The battery positive stud is to be controlled by the master disconnect switch mounted on the lower right dash panel. A green light shall indicate when the ignition circuit(s) are energized.

EDS MODULE

The EDS system shall be designed with locally available **plug-in** circuit breakers and **plug-in** relays. Each component position shall be labeled to indicate its function. All electrical connections shall be insulated and secured behind the panel face to eliminate the chance of accidental electrical shorts while performing electrical system service.

The EDS shall control a minimum of thirteen (13) low voltage, analog switched, high amperage electrical loads.

Provision for a minimum of thirty-one (31) automatic reset circuit breakers is required to protect the vital circuits of the apparatus.

The EDS system shall be removable with only four (4) fasteners for major electrical service or modifications.

The EDS panel shall have one (1) lamp for illumination of the panel during service.

CHASSIS COLOR CODED WIRING

All chassis wiring shall be type "GXL" in accordance with S.A.E. J1128 and NFPA-1901. ALL wiring shall be **COLOR CODED** and continuously marked with the circuit number and function.

All wiring to be covered in nylon heat resistant "HTZL" loom rated at a minimum of 300 degrees F exceeding the heat requirements of NFPA-1901.

A battery "loop back" ground circuit shall be supplied for the EDS system to reduce the possible effects of Electromagnetic and Radio Frequency Interference.

The chassis cab, engine and transmission shall be electrically bonded to the chassis frame rails with braided ground straps.

ELECTRICAL SYSTEM CONNECTORS

All multiple conductor electrical connections shall be made with Packard electrical connectors. The Packard connectors shall become mechanically locked when mated.

All single wire terminations requiring special connectors with a ring or spade terminal shall be crimped, and wrapped with heat shrink tubing.

CAB CRASHWORTHINESS TEST

Dynamic tests shall be performed to evaluate the crashworthiness of the proposed vehicle cab configuration to the requirements of NFPA 1901-09 section 14.3.2.

Cab roof strength shall be tested utilizing the dynamic preload criteria from SAE J24221 paragraph 5 specifications and procedures.

Front impact strength integrity shall be tested utilizing SAE J24202 with ECE R293 Annex 3 paragraph 4 equivalent energy.

Quasi-static roof strength shall be based on SAE J2422 paragraph 6 and ECE R293, paragraph 5 specifications and procedures.

A letter of certification shall be provided upon request by the department.

EXTERIOR GRAB HANDLES

The cab shall have a bright anodized extruded aluminum 24" grab handles at each door position. The aluminum shall be bright anodized for long service. Molded rubber gaskets shall be installed under the grab handles to protect the painted surface of the cab.

FRONT GRILLE - THREE DIMENSIONAL - FFA LOGO

A stainless steel square, three dimensional bright polished stainless steel front grille shall be installed on the front cab face. The front grille shall have a radiator rock guard to assist in preventing damage to the radiator core.

The cab shall have one (1) engine "hot" air exhaust and one (1) engine air cleaner intake, on each side of the cab. These openings shall be covered with a honey comb wire screen and shall have a bright polished stainless steel outer grille.

CAB GROUND LIGHTING - LED

One (1) LED, round 4" LED light shall be mounted beneath each door. These lights shall be designed to provide illumination on areas under the driver and crew riding area exits. All cab ground lights shall be switchable and shall automatically activate when any cab exit door is opened.

MIRRORS

MOTO-MIRROR 16 1/2" X 7" stainless steel heated, remote control mirror heads shall be mounted on spring loaded retractable mirror arms. Includes a 5-1/2" x 8.5" convex mirror head.

CAB SIDE WINDOWS

Two AS-2 tempered glass, fixed side windows, 26-1/2" high x 16" wide shall be furnished, one on each side behind the forward doors. All glass shall be tinted. These windows shall be installed with a one-piece triple locked rubber lacing material.

UNDER CAB ENGINE MAINTENANCE LIGHTS

Two (2) engine maintenance lights shall be supplied beneath the cab. These lights shall illuminate automatically when the cab is tilted to the full tilt position.

WHEEL WELL LINERS

To reduce road splash and allow for easy cleaning, bolt in front wheel well liners are to be installed. Stainless steel material is to be used for the liner for ease of cleaning and eliminate corrosive action created by road debris. The wheel well liners are to be a minimum of 22 inches in width.

STAINLESS CAB FENDERETTES

To reduce road splash on the cab sides, polished stainless steel fenderettes shall be installed around each the wheel opening.

EXTERIOR REAR WALL DIAMOND PLATE OVERLAY

The cab exterior rear wall shall be covered with a single sheet of bright aluminum tread plate to protect the back of the cab from scratches.

CAB TILT SYSTEM

The cab shall tilt a minimum of 45 degrees for ease of serving. Tilting shall be accomplished by means of a tilt pump connected to two (2) heavy duty lift cylinders. It shall be equipped with a positive locking mechanism (service lock) to hold the cab in the full tilt position. Release of the service lock shall be by means of a pull type cable assembly. The cylinders shall have a velocity fuse at the base to prevent the cab from falling in the event of a hydraulic hose failure. The cab shall be capable of tilting 90 degrees for major engine service, if necessary. The 90 degree cab tilt shall be accomplished by removing the cab cylinder pins, removing one bolt in the steering shaft, and removing the front bumper and treadplate.

The cab shall have a three (3) point cab locking system. To prevent undue stresses in the cab, the cab mounting shall incorporate a five (5) point load mounting system.

The front cab pivot/lock assemblies shall utilize four (4) radially loaded, bonded rubber, axial mounts. These mounts shall have a maximum radial load rating of 925 pounds each and a torsional rating of 25 lbs-in/deg. Two one (1) inch diameter cab pivot pins shall be installed at the front of the cab.

The rear cab lock shall be center point mounted to prevent normal twist of the chassis from affecting the cab mounting, cab structure and windshield areas of the cab. This rear cab lock shall be mounted on a chassis crossmember to provide a stable platform for the locking system. The cab lock shall be mounted to a baseplate that is fastened to rubber isolators to reduce road noise and provide additional movement of the cab lock. This locking system shall automatically open prior to the cab tilting and automatically relatch when the cab is lowered completely into the travel position.

Two (2) outboard frame mounted urethane "V" blocks shall be provided at the rear of the cab. These dual purpose mounts shall align the cab upon lowering as well as provide non-latching support for the cab in the down position. With this system, extreme chassis twist shall allow the cab to move independently of the rear cab supports, reducing the structural stress damage often caused by outboard dual cab locking systems.

An electric-over-hydraulic cab tilt pump shall be supplied. This pump shall have a remote control for cab tilting operation. The control shall be "safety-yellow" in color.

CAB TILT INTERLOCK

The cab lift system shall have a cab tilt interlock. The cab tilt shall not be able to be activated unless the master battery switch is in the on position with the parking brake set.

INTERIOR FINISH

The entire interior of the cab shall be painted with spatter paint, gray in color. Gray spatter paint is selected for ease of repairs when the interior is scratched.

The cab metal finish shall be covered with one coat of base self-etching primer to fill the small surface imperfections.

Then the interior of the cab is to be blocked and a coat of sealer-primer is to be sprayed to the interior finish.

Next a sealer primer is applied and shall be sanded to a smooth finish ready for final color coat application.

Two (2) coats of finished paint are to be applied to a final thickness of 4 mills.

The following interior components shall be finished in black:

- Overhead console
- Sun visors

The interior headliner of the cab shall be gray in color.

The interior rear wall covering of the cab shall be gray in color.

The interior flooring material of the cab shall be gray in color.

The doghouse covering material in the cab shall be gray in color.

The dash housing, doghouse console; when so equipped; and the officer's glove box or console shall be black in color.

CAB EXTERIOR FINISH

The exterior doors and all fixed cab glass are to be removed from the cab prior to the paint and body process beginning.

The final finish of the cab shall be to fire apparatus standards; exhibiting excellent gloss durability and color retention properties.

PREPARATION

The removal of all contaminants and oxidation is essential to the final effect of a finish system, the cab shall be precleaned with a Wax and Grease Remover and prior to evaporation, towel dried.

To remove all oxidation and foreign materials, the cab shall be sanded with a 180 grit abrasive using an orbital type disc sander.

All weld marks and other major surface imperfections shall be filled with a polyester type body filler, prior to body filler application special attention shall be given to the areas requiring filler again sanding and cleaning.

The body fillers shall be thoroughly mixed in accordance with the manufacturer's directions.

After the final coat of filler is sanded, spray polyester shall be applied in sufficient amounts as to provide a final base and sanded with abrasive paper.

PRECLEAN

Within 45 minutes of pretreat the cab must be again washed with a Wax and Grease Remover using a "Scotch brite pad". Towel dry prior to evaporation.

Special precaution shall be taken NOT to saturate any polyester body fillers with the cleaning solvents.

PRETREAT AND PRIMERS

The pretreat and primer applications shall be made in two independent steps. A combined pretreat/primer one product application shall not be allowed as a substitute.

The prepared substrate shall be pretreated with an acid curing 2-component Transparent Primer. This pretreat shall be designed to provide corrosion protection and to create an adhesive bond between the substrate and the surface applications.

It is critical that the body fillers not receive a saturation of solvents associated with the pretreat application. Only the pretreat over spray resulting from product application to the adjacent metal areas should be allowed to come in contact with the body fillers.

All polyester body fillers are porous, and shall absorb liquids. Solvents when absorbed not only soften but shall create swelling of the polyester filler. After sanding and later shrink the fillers shall create blemishes in the painted surfaces.

Prior to complete primer application, each area with applied body fillers be precoated with a 2-dry applications of primer (sander surfacer) of which shall be allowed to "Touch Dry" between coats. This procedure shall isolate the filled areas and protect them from subsequent product applications.

The primer (sander surfacer) shall be a poly-acrylic resin, zinc and chromate free surfacer that is designed to create a superb surface smoothness, increase the depth of color, and insure top coat gloss.

The cab after pretreat and precoat shall be primed with a 3 to 4 medium applications of a Hi-Build Tintable Surfacer.

To create a finish base that meets the rigid requirements of the fire and emergency service; the primed surface shall be dry sanded smooth thus removing all texture and surface imperfections with a 320 grit (minimum) sanding abrasive.

FINISH AND COLOR COATS

The color coat application shall consist of two to three applications of acrylic urethane color coat. After the color coat has been applied, the cabs shall be sprayed with 1.5 to 2.0 mills of clear coat finish. The clear coat finish is then sanded and buffed to remove any imperfections that can occur during the application of the color coat.

The final finish shall be free of dirt and sags and shall meet a minimum grade of 7 when compared to the "ACT" general orange peel standards by "ACT" Laboratories, Inc. Of Hillsdale, MI.

The final sanding and buffing of the clear coat shall result in a flat / glass like finish. The clear coat shall also provide a UV barrier to prevent fading and chalking.

PPG brand urethane materials will be used for the cab exterior paint.

CAB PAINT WARRANTY

The chassis manufacturer shall provide a limited parts and labor warranty to the original purchaser of the custom built cab & chassis for a period of sixty (60) months. The warranty period shall commence on the date the vehicle is delivered to the end user. The warranty shall include conditional items listed in the detailed warranty document which shall be provided upon request.

DRIVER'S SEATING POSITION

The seat shall be Seats, Inc. 911, non-suspension, high back seat with a 4" double locking fore and aft slide adjustment.

A red 3-point, shoulder harness type seat belt shall be supplied for the seat.

OFFICER'S SEATING POSITION

The seat shall be Seats, Inc. 911, Series Self-Contained Breathing Apparatus (SCBA) type seat with a fixed bottom cushion and a split head rest. The seat shall contain a SCBA filler pad for when the bottle is not in use.

A red 3-point, shoulder harness type seat belt shall be supplied for the seat.

CREW AREA - REAR FACING LEFT OUTBOARD SEAT POSITION

The seat shall be Seats, Inc. 911, Series Self-Contained Breathing Apparatus (SCBA) type seat with a fixed bottom cushion and a split head rest.

A red lap type, metal to metal quick release seat belt, with automatic seat belt retractor shall be provided for the seat.

CREW AREA - REAR FACING RIGHT OUTBOARD SEAT POSITION

The seat shall be Seats, Inc. 911, Series Self-Contained Breathing Apparatus (SCBA) type seat with a fixed bottom cushion and a split head rest.

A red lap type, metal to metal quick release seat belt, with automatic seat belt retractor shall be provided for the seat.

CREW AREA - FORWARD FACING LEFT INBOARD SEAT POSITION

The seat shall be Seats, Inc. 911, Series Self-Contained Breathing Apparatus (SCBA) type seat with a fixed bottom cushion and a split head rest.

A red 3-point, shoulder harness type seat belt shall be supplied for the seat.

CREW AREA - FORWARD FACING RIGHT INBOARD SEAT POSITION

The seat shall be Seats, Inc. 911, Series Self-Contained Breathing Apparatus (SCBA) type seat with a fixed bottom cushion and a split head rest.

A red 3-point, shoulder harness type seat belt shall be supplied for the seat.

FORWARD FACING SEAT RISER

The center forward facing seat(s) shall be installed on a powder coated aluminum riser. The front of the seat riser will be open without a restraint system to provide a location for storage of small lightweight gear.

The seats shall be gray in color.

RIP STOP FABRIC

The chassis seats shall have Rip Stop, denier nylon cloth, material in lieu of the standard vinyl. The seats shall have the Rip Stop material in the following applicable areas.

- Seat Base Top
- Seat Base Sides
- Seat Back Support Face
- Seat Back Support Sides
- Seat Headrests

SEAT BELT WARNING LABELS

The cab shall be equipped with two (2) seat belt warning labels. These labels are to be in full view of the occupants in the seated position.

VEHICLE DATA RECORDER

Apparatus shall be equipped with a Class1 "Vehicle Data Recorder and Seat Belt Warning System" (VDR/SBW) that is connected to the power train CAN (Controller Area Network) bus consisting of transmission (TCM), engine control (ECM) and antilock brake (ABS) modules mounted on the apparatus. The VDR/SBW will function per NFPA 1901-2009 sections 4.11 (Vehicle Data Recorder) utilizing the power train's J1939 data and 14.1.3.10 (Seat Belt Warning) using the Class1 "Seat Belt Input Module" for seat occupied and belt status information.

The VDR data shall be downloadable by USB cable to a computer using either Microsoft™ or Apple™ Operating Systems using Class 1/ O.E.M. supplied reporting software.

SEAT BELT WARNING SYSTEM

There shall be a seat belt indicator system supplied in the cab. The indicator system shall indicate seat belt use for each individual seating position when the seat is occupied, the seat belt remains unfastened and the parking brake is released.

A display panel shall be supplied in the dash area. The panel shall have an audible indicators and a red light display to indicate that a seat belt has not been fastened.

SEAT BELT WARNING SYSTEM - MONITOR

Mounted in the overhead console in the driver's area the indicator system shall indicate seat belt use for each individual seating position when the seat is occupied, the seat belt remains unfastened and the parking brake is released.

FRONT BUMPER

A 12" high heavy-duty 10 gauge, polished stainless steel, wraparound, 2-rib front bumper shall be provided the full width of the cab.

BUMPER EXTENSION

The front frame extension shall be bolted directly to the main rail. The extension and main rail joint shall have a 3/8" thick side plate for reinforcement. The completed apparatus must be able to be lifted at the front bumper without structural damage to the front extension for towing of a disabled vehicle.

The front bumper face shall extend 24 inches ahead of the front face of the cab skin.

TOW HOOKS

Two (2) chromed tow hooks shall be provided and shall be attached directly to the front frame extension under the bumper. These tow hooks shall be attached with two Grade 8 bolts with hardened washers and Grade "C" distorted thread locknuts.

AIR HORNS

Dual stutter tone air horns shall be recessed into the front bumper, one each side outboard of the frame rails.

AIR HORN IGNITION CONTROL

To eliminate inadvertent operation the chassis air horns shall be operable only when the battery selector and ignition switch are in the "ON" position.

AIR HORN CONTROL SWITCHES

One (1) foot switch for the air horns shall be provided on the left side of the driver's side cab floor and one (1) on the right side of the officer's side cab floor.

AIR HORN OPERATION

The air horn and the electric horn shall be sounded simultaneously by depressing the horn button in the steering wheel.

ELECTRONIC SIREN

A Whelen electronic siren control, model 295SLSA1 full feature with 17 Scan-Lock siren tones including Radio Rebroadcast, Public Address, Manual, Wail, Yelp, Air Horn, Electronic Mechanical Siren tones and Piercer tones and hard wired microphone, shall be provided.

The siren control shall be mounted on top of the engine doghouse within reach of the driver and officer.

SIREN SPEAKER

There shall be one (1) Cast Products polished aluminum 100 watt speaker provided. The speaker shall be recessed into the left (driver's) side of the front bumper immediately outboard of the chassis frame rails.

ELECTRONIC CHASSIS OPERATOR'S MANUAL

An electronic Operator's Manual w/Parts List - Two Sets shall be provided with the chassis.

An electronic Electrical System Manual shall be provided.

- This manual shall provide complete wiring schematics for the vehicle.
- The manual shall be provided with diagrams of the vehicle showing the wiring harness routing within the vehicle. Each of these diagrams shall include the connectors between the harnesses that provide a hyperlink to a drawing of the actual connector where pin functions can be examined.
- Schematics for each system of the vehicle shall be provided with hyperlinks to the connectors for pin designations and to the vehicle drawings for harness location within the vehicle.

An electronic Air System Manual shall be provided.

- This manual shall provide complete air system schematics for the vehicle.
- The manual shall be provided with diagrams of the vehicle showing the air tubing routing within the vehicle.
- Schematics for each system of the vehicle shall be provided with hyperlinks to the tanks and valves and to the vehicle drawings for exact location within the vehicle.

CAB ICC MARKER LIGHTING

Five (5) amber Whelen OS Series LED cab face mounted clearance lights shall be supplied, mounted above the windshield. These lights are to be mounted in a chrome flange.

Two (2) amber Whelen OS Series LED side clearance lights shall be supplied, one (1) each side mounted ahead of the front door. These lights are to be mounted in a chrome flange.

An amber diamond shaped reflector shall be mounted on the lower corner of each cab front door adjacent to the door hinge.

HEADLIGHTS

Four (4) rectangular halogen headlights shall be supplied.

When the parking brake is released and the master battery switch is in the on position, the head lamps shall be illuminated to 80% brilliance.

TURN SIGNALS

Two (2) rectangular Federal Signal, model QL64Z-TURN, LED turn signal lamps shall be mounted outboard of the front headlights on each side. These lights shall be amber in color.

LOW LEVEL WARNING LIGHTS

Two (2) Whelen warning lights, 600 Series, Super-LED light heads shall be mounted on the front of the chassis above the headlights located in the inner position on each side.

The light heads shall include an internal flasher with 14 flash patterns, steady-burn and Hi/Low power. The warning lights shall be programmed for Hi-power with the same flash pattern for both the right and left light head.

These two (2) lights fulfill the requirements for Lower Zone A lower level warning devices. Both warning light lenses shall be red in color.

GRAVELSHIELD

A gravelshield constructed of 1/8" (.125") embossed aluminum tread plate shall be installed above the frame extension between the bumper and the front face of the cab.

MUD FLAPS, FRONT

The front axle mud flaps shall be constructed from hard black rubber and installed behind the front axle.

TIRE CHAINS, AUTOMATIC

The rear axle shall be equipped with an ON-SPOT automatic tire chain system. The system shall provide instant traction at the touch of a switch, without having to stop the vehicle.

The driver's dash shall have an electric control switch, clearly labeled for operation of the tire chains. The switch shall be provided with a guard to prevent accidental deployment of the tire chains. The switch when activated shall open a frame mounted solenoid, allowing air from the chassis air system to enter the spring loaded air cylinder and lower the chain wheel. The rubber covered chain wheel shall contact the inside of the tire causing the chain wheel to rotate and deploy the chains. The ON-SPOT automatic chains shall have six-(6) lengths of chain, spaced at 60-degree intervals on the chain wheel, ensuring two chains between the tire and road surface for instant traction in slippery conditions whether accelerating, braking, or in a wheel lock up condition. The ON-SPOT chains can be activated with speeds of 2 MPH to 25 MPH. The ON-SPOT chains shall be operable in either forward or reverse for speeds up to 35 MPH.

When the chains are no longer needed the process is reversed, the dash board switch is turned off and the air is exhausted from the cylinder. The return springs in the air cylinder brings the chain wheels back to their resting position.

BATTERY CHARGING RECEPTACLE

There shall be a Kussmaul VW-8, 12-volt male power inlet receptacle wired to the 12-volt chassis batteries. The receptacle shall be configured to allow a remote 12-volt DC power source to charge the batteries. A matching male plug shall be provided and shipped loose with the apparatus.

SHORE POWER INLET PLATE

A shore-power "Inlet Plate" shall be permanently affixed at or near the power inlet.

The plate shall indicate the following:

- Type of Line Voltage
- Current Rating in Amps
- Power Inlet Type (DC or AC)

The battery charging receptacle cover shall be a Kussmaul 091-3YW, yellow in color.

FIRE PUMP MOUNTING

Extra heavy-duty mounting brackets shall be bolted to the chassis frame rails for the installation of the fire pump. The mounting brackets shall be positioned aligning the pump insuring the angular velocity of the driveline joints are the same at each end allowing for full capacity performance with minimal vibration.

REFLECTIVE STOP SIGNS

There shall be four-(4) "STOP" signs installed in the cab, one-(1) on the lower door panel of each cab door.

LOAD MANAGER

The apparatus shall be equipped with a Load Manager System for performing electrical load management. The Load Manager shall have two-(2) modes of operation, a "Calling Right of Way" mode, and a "Blocking Right of Way" mode. The "Blocking Right of Way" mode is activated only when the park brake is set. Load shedding may occur "only" in the "Blocking Right of Way" mode also when the battery voltage level reaches your programmed shed level.

This system shall be designed to activate a fast idle system with low voltage alarm that activates at the NFPA required 11.8 volts.

SAFETY SIGNS, GENERAL REQUIREMENTS

Safety signs with text shall conform to the general principles of ANSI/NEMA Z535.4, *Product Safety Signs and Labels*. Safety signs without text shall conform to the general principles for two-panel safety signs of ISO 9244, *Earth-Moving Machinery - Machine Safety Labels*.

Apparatus built for sale in the United States shall employ safety signage that complies with ANSI/NEMA Z535.4.

Apparatus built for sale outside the United States shall employ safety signage that complies with ANSI/NEMA Z535.4 or ISO 9244.

Safety signs referenced in this standard beginning with the letters FAMA shall conform to the text and graphics of the referenced safety sign number found in FAMA TC010, *Standard Product Safety Sign Catalog for Automotive Fire Apparatus*.

CARRYING CAPACITY PLATE

A permanently attached carrying capacity plate in accordance with the current NFPA 1901 Standards shall be installed in plain view of the driver.

The tag shall include the following:

Overall height

Overall length

GVWR

Seating capacity

SAFETY SIGNS, SEATED & BELTED

Safety signs FAMA07, which warns of the importance of seat belt use, shall be visible from each seat that is intended to be occupied while the vehicle is in motion.

SAFETY SIGN, CAB EQUIPMENT MOUNTING

A safety sign FAMA10, which warns of the need to secure items in the cab, shall be visible inside the cab.

SAFETY SIGN, FIRE SERVICE TIRE RATING

A safety sign FAMA12, which warns of the special requirements for fire service-rated tires, shall be visible to the driver entering the cab of any apparatus so equipped.

SAFETY SIGN, CAB SEATING

A safety sign FAMA25 shall be located in the cab visible to the operator.

The sign shall read:

This vehicle has a seating capacity of 6 personnel.

Carrying additional personnel may result in death of serious injury.

SAFETY SIGNS, HELMET WORN IN CAB

A safety sign FAMA15, which warns not to wear helmets while the vehicle is in motion, shall be visible from each seat that is intended to be occupied while the vehicle is in motion.

SAFETY SIGNS, CLIMBING METHOD INSTRUCTION

Safety signs FAMA23, which warns of the proper climbing method, shall be visible to personnel entering the cab and at each designated climbing location on the body.

SAFETY SIGNS, RIDING ON EXTERIOR

Safety signs FAMA24, which warns personnel not to ride on the vehicle, shall be located at the rear step areas and at any cross walkways.

PLATE, OVERALL HEIGHT/LENGTH/WEIGHT

An Overall Height/Length/Weight information plate shall be installed that can be clearly identified and visible to the driver while in the seated position showing the apparatus completed overall height, length, (in feet and inches) and gross vehicle weight (in tons) current to the apparatus manufactured date.

If changes to the vehicle occur while in service, the department must revise the overall height-length-weight plate.

PLATE, FLUID CAPACITY

A permanently affixed fluid data plate shall be installed in the driving compartment to indicate the type and quantities of the following fluid used in the vehicle.

- Engine Oil
- Engine Coolant
- Chassis Transmission Fluid
- Pump Transmission Lubrication Fluid (if applicable)
- Pump Primer Fluid (if applicable)
- Drive Axle Lubrication Fluid
- Air Conditioning Refrigerant
- Air Conditioning Lubrication Oil
- Power Steering Fluid
- Cab Tilt Mechanism Fluid
- Transfer Case Fluid
- Equipment Rack Fluid
- Air Compressor System Lubricant
- Generator System Lubricant
- Front Tire Pressure - Cold
- Rear Tire Pressure - Cold

The following information shall also be supplied on the Fluid Data Plate:

- Chassis Manufacturer
- Production Number
- Paint Number
- Year Built
- Date Shipped
- Vehicle Identification Number

SAFETY SIGN, APPARATUS MOVEMENT

A permanently affixed movement warning plate shall be installed near the door ajar light that reads:

"DO NOT MOVE APPARATUS WHEN LIGHT IS ON".

PUMP ENCLOSURE, SIDE CONTROL

The pump enclosure superstructure shall be constructed of aluminum tubing, channel, angle, and break-formed components. The framework shall be formed by beveled aluminum alloy extrusions and electrically seam welded both internally and externally at each joint using 5356 aluminum alloy welding wire. The main, frame work shall be constructed of 3.00 x 3.50, 6063-T6 aluminum extrusions. The break-formed components shall be constructed from 3/16" (1.875) aluminum.

The crossmembers support the substructure and the exterior panels independently from the cab and body. The crossmembers shall be isolated from the frame rails using torsion mounts. The pump enclosure shall be supported at the top of the frame rails, in a minimum of four-(4) places. The module shall be secured with angle brackets bolted to both the pump enclosure support cross rails and the side of the chassis frame rails. This design is required to eliminate shifting and stress on the pump enclosure, pump panels, and running boards.

The front of the pump module shall be covered with aluminum tread plate to keep road debris from the front of the pump.

The pump enclosure provides an area above the pump for the installation of crosslays or dunnage area.

Any pump enclosure constructed using any material other than aluminum or utilizing any other mounting method is not acceptable.

PUMP PANELS

The operator's controls and gauges shall be mounted on pump panels constructed of 1/8" (.125) black anodized, non-glare aluminum. No vinyl coverings shall be acceptable as these surfaces are subjected to rough service and vinyl is susceptible to tearing.

The operator's master gauge panel shall be vertically hinged with push style latch for access to gauges and auxiliary controls.

The operator's control panel shall be located below the master gauge panel and constructed of 1/8" (.125) black anodized, non-glare aluminum.

All gauges and controls shall be properly identified with color-coded metal tags. The tags shall be affixed with 3M brand industrial adhesive. The gauges shall be functionally grouped above each control.

The right side upper panel shall be vertically hinged with double doors and push style latches for pump compartment access. The doors shall be constructed of .125" aluminum tread plate.

The right side lower panel shall be removable for serviceability. The panel shall be constructed of 1/8" (.125) black anodized, non-glare aluminum.

All instruments and controls shall be provided and installed as a group at the pump panel. The central midpoint or centerline of any valve control shall be no more than 72" vertically above the ground or platform that is designed to serve as the operator's standing position. The instruments shall be placed to keep the pump operator as far as practical from all discharge and intake connections and in a location where they are readily visible and operationally functional while the operator remains stationary.

A safety sign FAMA25, which warns of the need for training prior to operating the apparatus, shall be located on the pump operators panel.

PUMP PANEL LIGHT, LEFT SIDE

One-(1) individual OnScene Access LED pump panel light with on/off switch shall be mounted under the light shield left side. For optimum visibility during nighttime operations, the light shall be mounted as high as possible.

PUMP PANEL LIGHT, RIGHT SIDE

One-(1) individual OnScene Access LED pump panel light with on/off switch shall be mounted under the light shield right side. For optimum visibility during nighttime operations, the light shall be mounted as high as possible.

LIGHTS, PUMP COMPARTMENT

One-(1) compartment light shall be installed in the pump compartment for inspection or routine maintenance wired to the pump panel light switch.

RUNNING BOARD, LEFT SIDE

A running board shall be provided on the left side of pump module constructed of anodized aluminum extrusion slotted, punched, and raised to provide superior traction during inclement weather operations.

Bolted to the pump modules substructure the running board shall be spaced out 1/4" from the module for additional run off.

The running board stepping surface shall comply with the latest version of NFPA 1901.

RUNNING BOARD, RIGHT SIDE

A running board shall be provided on the right side of pump module constructed of anodized aluminum extrusion slotted, punched, and raised to provide superior traction during inclement weather operations. Bolted to the pump modules substructure the running board shall be spaced out 1/4" from the module for additional run off.

The running board stepping surface shall comply with the latest version of NFPA 1901.

PRESSURE GAUGES, 2-1/2"

The discharges shall be provided with 2-1/2" pressure gauges. The discharge gauges shall be liquid filled with a solution to assure visual readings and reduce inner lens condensation. The body of the gauges shall be constructed of Zytel nylon with chrome-plated bezels. The face of the gauges shall be Spun Metal with black background and white markings reading from zero to 400 PSI.

The gauges shall be installed at each discharge control on the pump operator's panel. On side mount pump applications with push pull handles each gauge shall incorporate a Thuemling Instrument Group 1-piece module assembly consisting of the gauge, push-pull and trim bezel.

The pressure gauges shall maintain performance of all features and be free from defects in material and workmanship which includes fluid fill leakage and discoloration for seven years.

GAUGE BEZELS, COLOR CODED

The pump panel master and pressure gauge bezels shall be color coded.

PUMP PANEL TAGS

All discharges, gauges, and controls will be properly identified by color-coded metal tags. The metal tags will be affixed with 3M industrial adhesive.

PUMP SYSTEM, HALE QMAX SINGLE STAGE

PUMP ASSEMBLY

The entire pump shall be cast, manufactured, and tested at the pump manufacturer's factory.

The pump shall be driven by a driveline from the truck transmission. The engine shall provide sufficient horsepower and RPM to enable pump to meet and exceed its rated performance.

The entire pump, both suction and discharge passages, shall be hydrostatically tested to a pressure of 600 PSI. The pump shall be fully tested at the pump manufacturer's factory to the performance specs as outlined by the latest NFPA Pamphlet No. 1901. The pump shall be free from objectionable pulsation and vibration.

The pump body and related parts shall be of fine grain, cast iron alloy, with a minimum tensile strength of 30,000 PSI. All moving parts in contact with water shall be of high quality bronze or stainless steel. Pump utilizing castings made of lower tensile strength cast iron not acceptable.

Pump body shall be horizontally split, on a single plane, in two sections, for easy removal of entire impeller assembly including wear rings and bearings from beneath the pump without disturbing piping or the mounting of the pump in chassis.

The pump shall have one double suction impeller. The pump body shall have two opposed discharge volute cutwaters to eliminate radial unbalance.

Pump shaft to be rigidly supported by three bearings for minimum deflection. One high lead bronze sleeve bearing shall be located immediately adjacent to the impeller (on side opposite the drive unit). The sleeve bearing is to be lubricated by a force-fed, automatic oil lubricated design, pressure balanced to exclude foreign material. The remaining bearings shall be heavy-duty, deep groove ball bearings in the gearbox and they shall be splash lubricated.

The pump impeller shall be hard, fine grain bronze of the mixed flow design; accurately machined, hand-ground and individually balanced. The vanes of the impeller intake eyes shall be hand ground and polished to a sharp edge, and be of sufficient size and design to provide ample reserve capacity utilizing minimum horsepower.

The impeller clearance rings shall be bronze, easily renewable without replacing impeller or pump volute body, and of wraparound double labyrinth design for maximum efficiency.

The pump shaft shall be heat-treated, electric furnace, corrosion resistant, stainless steel, to be super-finished under packing with galvanic corrosion (zinc separators in packing) protection for longer shaft life. Pump shaft must be sealed with double lip oil seal to keep dirt and water out of drive unit.

DRIVE UNIT

The drive unit shall be cast and completely manufactured and tested at the pump manufacturer's factory.

Pump drive unit shall be of sufficient size to withstand up to 16,000 ft. Lbs. Torque of the engine in both road and pump operating conditions. The drive unit is designed with ample capacity for lubrication reserve to maintain proper operating temperature.

The gearbox drive shafts shall be of heat-treated chrome nickel steel and at least 2-3/4" in diameter, on both the input and output drive shafts. They shall withstand the full torque of the engine in both road and pump operating conditions.

All gears drive and pump, shall be of highest quality electric furnace, chrome nickel steel. Bores shall be ground to size and teeth integrated, crown-shaved and hardened, to give an extremely accurate gear for long life, smooth, quiet running, and higher load carrying capability. An accurately cut spur design shall be provided to eliminate all possible end thrusts.

The pump ratio shall be selected by the apparatus manufacturer to give maximum performance with the engine and transmission selected.

If drive unit is equipped with a power shift, the shifting mechanism shall be a heat-treated, hard-anodized aluminum power cylinder, with stainless steel shaft. An in-cab control for rapid shift shall be provided that locks in road or pump.

Three warning lights with plates shall be provided to alert the operator when the drive unit has fully shifted from road to pump position. Two lights shall be located on the cabs instrument panel and the other on the pump panel adjacent to the throttle.

A 3" clapper check valve shall be installed between the suction side of the pump and the tank-to-pump valve. This 3" clapper valve shall remove the possibility of a water surge expanding the booster tank.

Pump system shall have an integral discharge manifold system that allows a direct flow of water to all discharge valves.

PACKING GLANDS

The pump shaft shall have only one packing gland located on the inlet side of the pump. It shall be of split design for ease of repacking. The packing gland must be a full circle threaded design to exert uniform pressure on packing and to prevent "cocking" and uneven packing load when it is tightened. It shall be easily adjusted by hand with rod or screwdriver, with no special tools or wrenches required. The packing rings shall be of a unique, permanently lubricated, long life graphite composition and have sacrificial zinc foil separators to protect the pump shaft from galvanic corrosion.

PUMP SHIFT

An air operated pump shift shall be installed in the chassis cab to engage the fire pump. Provisions shall be made for placing the pump drive system in operation using controls and switches that are clearly identified and within convenient reach of the operator while in the cab.

A green indicator light shall be installed on the cab dash and labeled "Pump Engaged".

Where an automatic chassis transmission is provided, a green indicator light in the driving compartment and a green indicator light located at the pump operator's position shall be provided and shall be energized when both the pump shift has been completed and the chassis transmission is engaged in pump gear.

The light in the driving compartment shall be labeled "OK TO PUMP". The light on the pump operator shall be positioned adjacent to and preferably above the throttle control and shall be labeled "Warning: DO NOT OPEN THROTTLE UNLESS LIGHT IS ON". The green light on the pump operator's panel shall be energized when the pump is engaged, the transmission is in drive, and the parking brake is set.

PRIMING SYSTEM, PUMP

A Hale model ESP 12 volt positive displacement vane primer shall be installed. The primer shall be electrically driven and conform to the standards outlined in the current NFPA Pamphlet. The system is an oil-less system and environmentally safe. It contains an electric rotary vane type positive displacement primer that operates off 12V or 24V power. The primer motor is totally enclosed to prevent dust, dirt and water from penetrating. The unit is constructed of heat-treated anodized aluminum, specially coated for wear and corrosion resistance. The control shall be pump panel mounted to operate the priming valve and start the priming motor.

U.L. TEST POINTS

An Underwriters Laboratories approved engine speed counter shall be located on the pump panel to provide a means to certify the tachometer. In addition, two (2) U.L. test plugs shall be pump panel mounted for testing of vacuum and pressures.

U.L. CERTIFICATION, 1500 GPM

The vehicle shall be third party tested and certified by Underwriters Laboratories, Inc. UL testing is recognized as a leading, third party, product safety certification organization for over 100 years. UL has served on the NFPA (National Fire Protection Association) technical committee for over thirty-(30) years.

The testing organization must meet the following minimum requirements:

- Must be nationally recognized testing laboratory recognized by OSHA
- Must comply with the ASTM (American Society for Testing Materials) standard E543 "Determining the qualifications for nondestructive testing agencies"
- Must have more than forty (40) years of Automotive Fire Apparatus safety testing experience and more than fifteen (15) years of factory aerial device testing and Certification experience
- Must not represent, be associated with, or in the manufacture or repair of automotive fire apparatus
- Must provide proof of ten-(10) million dollars in excess liability insurance for bodily injury and property damage combined

The pump shall meet and perform the following test to receive a U.L. Certification.

- 100% of rated capacity at 150 PSI net pump pressure
- 100% of rated capacity at 165 PSI net pump pressure
- 70% of rated capacity at 200 PSI net pump pressure
- 50% of rated capacity at 250 PSI net pump pressure

PUMP TEST CERTIFICATION PLATE

A permanently affixed plate shall be installed at the pump operator's panel. It shall provide the rated discharge and pressures together with the speed of the engine as determined by the certification test for each unit. It shall also provide the position of the parallel/series pump used and the no load governed speed of the engine as stated by the engine manufacturer on a certified brake horsepower curve.

A label shall be provided on the pump operator's panel that states the following: "Warning: Death or serious injury might occur if proper operating procedures are not followed". The pump operator as well as individuals connecting supply or discharge hoses to the apparatus must be familiar with water hydraulics hazards and component limitations.

SUCTION HEADERS

A 6" NST non-gated suction header with removable screen, and long handled cap shall be provided on the left side of the pump.

A 6" NST non-gated suction header with removable screen, and long handled cap shall be provided on the right side of the pump with an open flange to accept the front suction plumbing.

FRONT SUCTION INLET

A 5" gated front suction inlet shall be installed vertically thru the front bumper extensions gravelshield and turn 90 degrees forward terminating 5" FNPT x 5" MNST with chrome plated adapter and strainer.

The suction inlet shall be controlled at the pump operator's panel by an air-operated butterfly valve, with built in relief valve mounting pad, and indicator package. A bleeder valve shall also be provided.

An Akron Model 59 relief valve shall be provided for the front suction adjustable from 50 to 175 PSI and pre-set at the factory at 125 PSI.

The front suction plumbing shall be constructed from black iron plumbing with victaulic or roustabout couplings at each end, the plumbing shall be contoured and form fitted routed along the chassis frame rails connecting the pumps suction header plumbing to the front 90 degree elbow.

A warning plate permanently affixed in close proximity of the suction inlet shall be installed stating:

"WARNING - SERIOUS INJURY OR DEATH COULD OCCUR IF INLET IS SUPPLIED BY A PRESSURIZED SOURCE WHEN THE VALVE IS CLOSED".

A 3/4" ball valve shall be provided for the front suction located at the lowest point of the plumbing and properly labeled. The valve shall have a cast bronze body, with a 1/4 turn, chrome plated bronze ball, reinforced Teflon seals, and blow-out-proof stem rated to 600 PSI.

INTAKE RELIEF VALVE

There shall be an Akron model 59 suction side relief valve provided in the pump system. The relief valve is adjustable from 50-175 psi and set at the factory at 125 psi.

PRESSURE RELIEF VALVE

There shall be a Hale QG pressure relief valve provided. This automatic pressure control device shall be a single bronze variable pressure setting relief valve of ample capacity to prevent an undue pressure rise as per NFPA Pamphlet No. 1901. An increase in pump pressure shall open the normally closed valve. A control light on the pump panel shall be installed to signal when open. In event of relief valve control failure, the pump is to remain operable for the complete range of the pump's rated capacity, without requiring the closing of any emergency or "in case of failure" (off/on) valves.

The pressure relief shall discharge to atmosphere, and the discharge shall direct away from the operator's position.

MASTER GAUGES, 4-1/2"

Two compound 4-1/2" master gauges shall be provided and installed on the pump operator's panel. The intake and discharge gauges are liquid filled with a solution to assure visual readings and reduce inner lens condensation. The body of the gauges shall be constructed of Zytel nylon with chrome-plated bezels. The face of the gauges shall be Spun Metal with black background and white markings accurate within 1%.

The pressure gauges shall maintain performance of all features and be free from defects in material and workmanship which includes fluid fill leakage and discoloration for seven years.

ENGINE THROTTLE

There shall be a Vernier engine throttle with quick release at the center of the controller. The throttle shall be mounted on the pump panel.

NFPA INDIVIDUAL GAUGE PACKAGE

The following monitoring devices shall be installed on the pump operator's panel in compliance with the latest version of NFPA.

- 2" weatherproof oil pressure gauge
- 2" weatherproof engine coolant temperature gauge
- 3" tachometer indicating engine revolutions per minute
- 2" voltmeter that reads from 8 to 16 volts

There shall be an audible alarm, with warning indicator lights, mounted behind the pump operator's panel, connected to the oil pressure and water temperature gauges alerting the pump operator if low oil pressure or high water temperature condition exists.

TANK TO PUMP

One (1) 3" ball valve shall be installed between the pump and the water tank. The tank to pump valve shall be a quarter turn fixed pivot design constructed from bronze. The valve shall be controlled by a chrome push/pull locking "T" handle installed at the left pump panel.

FOAM SYSTEM

There shall be a Foam Pro 1600 fully automatic, variable speed, electronic direct injection, discharge side foam proportioning system furnished and installed on the apparatus. The system shall be capable of Class A foam concentrate **ONLY**. The proportioning operation shall be based on an accurate direct measurement of water flows with no water flow restriction. The foam system shall be installed in accordance with the manufacturer recommendations. System must be capable of delivering accuracy to within 3% of calibrated settings over the advertised operation range with installed. The system shall be equipped with a control module suitable for installation on the pump panel. Incorporated within the motor driver shall be a microprocessor that receives input from the system flowmeter, while also monitoring the foam concentrates pump output, comparing values to endure that the operator preset proportional amount of foam concentrate is injected into the discharge side of the fire pump. A paddlewheel type flow meter shall be installed in the discharge system specified to be "foam capable".

The system shall be equipped with a control module. It shall be installed on the pump operators panel and enable the pump operator to perform the following functions:

- Activate the foam system
- Change foam concentrate proportioning rates from 0.1% to 1.0%
- Flash a "Low Concentrate" warning light when the foam concentrate and in two (2) minutes if foam concentrate is not added to tank shut the foam concentrate pump down

The foam system shall have a 12-volt electric motor driven positive displacement plunger pump shall be provided. The pump capacity shall be 1.7 GPM with operating pressure up to 200 PSI with a maximum operating pressure up to 400 psi. The system shall draw a maximum of 30 amps at 12VDC. The motor shall be controlled by the microprocessor mounted to the base of the pump. It receives its signal from the control module and power the 1/3 HP electric motor in a variable speed duty cycle to ensure the correct proportion of concentrate is injected into the water system. A full flow check valve shall be provided in the discharge piping to prevent foam contamination of fire pump and water tank. A pressure check valve shall be installed the foam concentration line and shall open at 5-psi.

Components of the complete system shall be:

- Operator control module
- Paddlewheel flowmeter
- Pump and electric motor/motor driver
- Wiring harness
- Low-level tank switch
- Foam tank
- Check valve: Foam injection
- Check valve: Main waterway

An installation and operation manual shall be provided for the unit along with a one-(1) year limited warranty. The system design shall have passed environmental testing with simulates heavy use on off road mobile apparatus. Testing shall have been conducted in accordance to SAE standards.

STAINLESS STEEL FOAM MANIFOLD

The foam manifold shall be constructed of stainless steel.
FLOWMETER, 2" TEE MOUNT W/COUPLING KIT

There shall be a paddle wheel style flowmeter mounted in a 2" NPT pipe tee for mounting in a 2" discharge line. A groove less Victaulic coupling shall be provided for installation of the flowmeter. A water check valve shall be installed before the flowmeter and between the water pump and the foam injection point.

FOAM PROPORTIONING SYSTEM TEST

NFPA 1901 PERFORMANCE REQUIREMENTS

The proportioning system shall be capable of proportioning foam concentrate in accordance with the foam concentrate manufacturer's recommendation for the type of foam concentrate used in the system over the system's design range of flow and pressure. The foam proportioning systems water flow characteristics and the range of proportioning ratios shall be specified.

The foam system shall comply with NFPA 1901 Chapter 17.0 as it relates to the specified system.

FOAM TANK PIPING

The foam supply line shall be non-collapsible. There shall be a means provided to prevent water backflow in to the foam proportioning system and storage tank(s).

Either a filter or strainer provided on the foam concentrate supply side of the foam proportioning to prevent any debris that may affect the operation of the foam proportioning system from entering the system. The strainer assembly shall consist of a removable straining element, housing, and retainer. The strainer assembly shall allow full flow capacity of the foam supply line.

FLUSHING

Foam concentrate system flush line(s) shall be provided as required by the foam system manufacturer. The design shall incorporate a means to prevent water backflow into the concentrate tank or water tank during the flushing operation. Where the foam proportioning system is connected to more than one (1) foam storage tank, provisions shall be made to flush all common lines to avoid contamination of dissimilar foam concentrates.

CONTROLS FOR FOAM SYSTEM

The foam proportioning system operation controls shall be located at or near the pump operator's position and shall be clearly labeled.

All foam-proportioning systems that require flushing shall provide controls, which enable the operator to flush the system in accordance with the foam manufacturer's instructions.

Foam proportioning systems that incorporate foam concentrate metering valves shall have each metering valve calibrated to indicate the rate(s) of flow of the foam concentrate proportioning available as determined by the design of the system.

Foam proportioning systems that incorporate automatic proportioning features shall be equipped with controls, which enable the operator to isolate the automatic feature and operate the system in a manual mode.

NAMEPLATE, LABELS, INSTRUCTION SPECIFICATIONS

There shall be a nameplate provided that is clearly marked with the identification and function of each control gauge and indicator related to the foam proportioning system.

There shall be a label provided on the operator's panel that identifies the type(s) of foam concentrate(s) the system is designed to use. This label shall state the minimum/maximum foam-proportioning rate at the minimum/maximum foam proportioning rated system flow and pressure.

Foam proportioning system instruction plate shall be provided. This includes a minimum piping schematic of the system and basic operating instructions.

Two (2) copies of an operations and maintenance manual shall be provided. These manuals shall include a complete diagram of the system, along with operating instructions and details outlining all recommended maintenance procedures.

FOAM PROPORTIONING SYSTEM TESTING

The apparatus manufacturer shall test the accuracy of the foam proportioning system prior to delivery of the apparatus.

If the manufacturer's rated proportioning ratio is below 3%, the foam system shall proportion foam concentrate within 0% /+40% of the manufacturer's rated proportioning ratio across the manufacturer stated range of water flow and pressure.

If the manufacturer's rated proportioning ratio is above 3%, the foam system shall proportion foam concentrate within 0% /+40% of the manufacturer's rated proportioning ratio or 1 percentage point, whichever is less across the manufacturer's stated range of water flow and pressure.

LOW TANK SWITCH

A low level-tank sensor switch shall be installed in the foam tank. The sensor shall be mounted to indicate to the Display Control Module when the foam cell has approximately five (5) gallons of concentrate left.

OPERATING SYSTEMS INSTRUCTION PLACARD, SINGLE TANK

There shall be a placard installed on the pump panel, a schematic of the Foam Pro (single tank) operating system, which has been installed.

FOAM TANK NO. 1

The foam tank shall have a capacity of 30 gallons designed as an integral part of the water tank and shall have a manual fill tower. The fill tower shall be constructed of 1/2" PT3™ polypropylene and shall be a minimum dimension of 8" x 8" outer perimeter. Each foam fill tower shall be constructed of a colored material (yellow, green and black) indicating which tower is to receive each type of foam utilized. The capacity of the tank shall be engraved on the top of the fill tower lid. The tower shall be located in the right front corner of the tank unless otherwise specified. The tower shall have a 1/4" thick removable polypropylene screen and a stainless steel hinged-type cover. Inside the fill tower, approximately 1.5" down from the top, there shall be an anti-foam fill tube that extends down to the bottom of the tank. A pressure vacuum vent shall be provided in the lid of the fill tower.

FOAM OUTLETS

Foam shall be plumbed to the following outlets:

- No. 1 Crosslay
- Rear of Body Left Side

VALVE, MASTER DRAIN

There shall be a master drain valve recessed mounted below the pump module under the side running board, connecting all drain lines, with the capacity to discharge water simultaneously from all locations to below the chassis frame rails.

VALVE, INDIVIDUAL DRAIN

All lines shall drain through the master drain valve or shall be equipped with individual drain valves, easily accessible and labeled.

One-(1) individual quarter turn drain valve shall be furnished for each 1-1/2" or larger discharge port and each 2-1/2" gated auxiliary suction.

The drain/bleeder valves shall be located at the bottom of the side pump module panels.

All drains and bleeders shall discharge below the running boards.

TANK FILL

There shall be a 2" pump to tank fill line installed, with a 2" inline bronze valve and high-pressure flexible hose tested to 1200 PSI. The valve shall be (locking "T" handle) push-pull controlled at the pump operator's panel.

ENGINE COOLER

The engine cooler shall be installed in-line from the discharge side of the pump, and installed in the engine cooling system. There shall be a 1/2", quarter turn valve installed thru the pump panel and shall be clearly labeled.

PUMP COOLER

The pump shall have a 3/8" line installed from the pump discharge, to the water tank to cool the pump during long periods of pumping when water is not being discharged. The pump cooler shall be controlled from the pump operators panel by a 3/8" valve consisting of a cast bronze body with 1/4 turn chrome plated bronze ball, reinforced Teflon seals, and blow-out-proof stem rated to 600 PSI.

The valve shall be installed thru the pump panel and clearly labeled.

PLUMBING SYSTEM

All suction and discharge lines of 2" or larger shall be constructed of a minimum of Schedule 40 galvanized steel pipe, where vibration or chassis flexing may damage or loosen threaded pipes, Victaulic or Roustabout couplings shall be used. All suction and discharge outlets shall have National Standard Threads (NST) and designed for 500 PSIG including, valves, drain cocks, lines, intake, and outlet closures, excluding the tank fill and tank to pump lines (tank side of the valves).

PUMP PAINTING

The pump shall be painted black in color.

AKRON PUSH-PULL CONTROL VALVE PACKAGE

All discharge valves shall be Akron Heavy-Duty Swing-Out push/pull controlled from the pump operator's panel unless otherwise specified.

The Akron Swing-Out Heavy-Duty valves are designed for operating pressures to 250 psi (17 bars)

- 10-year warranty against manufacturer's defects
- Available in 1"to 4" sizes

- 90° handle travel 316 stainless steel ball with Hydromax technology
- Improved sealing & increased gating ability
- Flow optimization reduces turbulence while in the gated position and requires lower operating forces
- No lubrication or regular maintenance required
- Simple two seated design (no O-Rings to cut or lose during assembly or maintenance)
- Wide range of available adapters
- Designed and tested to exceed NFPA requirements
- Cast, machined and assembled at our facilities in Wooster, Ohio

All valve packages shall meet current NFPA 1901 Standards for valve operating speeds when controlled by gear, electric actuator, or slow close device.

SUCTION, 2-1/2" LEFT FRONT PANEL

One-(1) 2-1/2" swing operated ball valve shall be installed at the pump panel, left front plumbed to the suction side of the pump with 2-1/2" piping, 2-1/2" FNST chrome inlet swivel, brass inlet strainer, chrome plug with chain, and 3/4" drain valve.

A warning plate permanently affixed in close proximity of the suction inlet shall be installed stating:

"WARNING - SERIOUS INJURY OR DEATH COULD OCCUR IF INLET IS SUPPLIED BY A PRESSURIZED SOURCE WHEN THE VALVE IS CLOSED".

DISCHARGE ELBOWS

All 2-1/2" side discharge outlets shall terminate with chrome-plated 30-Degree elbows with 2-1/2" MNST threads, chrome vented cap and chain.

Caps shall automatically release pressure in the discharge outlet before the threads are completely disengaged unless the outlet and the cap are equipped with drains or bleeder valves.

NO. 1 CROSSLAY, 1-3/4" DOUBLE LAY

One-(1) pre-connected crosslay compartment shall be provided above the side mount operator's panel accommodating 200' of 1-3/4" double jacket hose. Stainless steel nylon guided rollers shall be installed at each end with stainless steel scuff plates around the perimeter to protect the painted surface.

One-(1) 2" ball valve with mechanical swivel shall be installed. The valve shall be plumbed to the crosslay with 2" high-pressure flexible hose and stainless steel couplings. The high pressure hose shall be tested to 1200 PSI. The crosslay valve shall be push-pull controlled at the pump operator's panel.

Each discharge is equipped with a 3/4 quarter-turn drain valve.

NO. 2 CROSSLAY, 1-3/4" DOUBLE LAY

One-(1) pre-connected crosslay compartment shall be provided above the side mount operator's panel accommodating 200' of 1-3/4" double jacket hose. Stainless steel nylon guided rollers shall be installed at each end with stainless steel scuff plates around the perimeter to protect the painted surface.

One-(1) 2" ball valve with mechanical swivel shall be installed. The valve shall be plumbed to the crosslay with 2" high-pressure flexible hose and stainless steel couplings. The high pressure hose shall be tested to 1200 PSI. The crosslay valve shall be push-pull controlled at the pump operator's panel.

Each discharge is equipped with a 3/4 quarter-turn drain valve.

CROSSLAY DIVIDER

One-(1) crosslay hosebed divider shall be provided manufactured from 1/4" (.250") smooth aluminum plate, extruded aluminum base mounted in an extruded track for horizontal adjustment, with radius corners, and DA sanded to prevent damage to the hose.

CROSSLAY COVER

There shall be a Hypalon crosslay cover provided with the apparatus secured by twist-lock connectors along the top, and Velcro closures on each end protecting the crosslay hose. The cover prevents hose from inadvertently deploying during normal operations meeting the current NFPA requirements.

A safety sign FAMA22, which warns of the need to secure hose, shall be visible to personnel at the hose storage area.

The Hypalon end flaps shall be secured at the bottom using pushpins. The cover prevents hose from inadvertently deploying during normal operations meeting the current NFPA requirements.

The covers shall be red in color.

DISCHARGE, 2-1/2" LEFT FRONT PANEL

One-(1) Akron 2-1/2" Heavy-Duty ball valve with 3/4" drain shall be installed at the pump panel left front plumbed to the discharge side of the pump push/pull controlled from the pump operator's panel.

DISCHARGE, 2-1/2" LEFT REAR PANEL

One-(1) Akron 2-1/2" Heavy-Duty ball valve with 3/4" drain shall be installed at the pump panel, left rear, plumbed to the discharge side of the pump push/pull controlled from the pump operator's panel.

DISCHARGE, 2-1/2" RIGHT FRONT PANEL

One-(1) Akron 2-1/2" Heavy-Duty ball valve with 3/4" drain shall be installed at the pump panel, right front, plumbed to the discharge side of the pump push/pull controlled from the pump operator's panel.

DISCHARGE, 2-1/2" RIGHT REAR PANEL

One-(1) Akron 2-1/2" Heavy-Duty ball valve with 3/4" drain shall be installed at the pump panel, right rear, plumbed to the discharge side of the pump push/pull controlled from the pump operator's panel.

DECK GUN PLUMBING, 3"

One-(1) Akron 3" Heavy-Duty (Slo-Close) inline valve with 3/4" drain shall be plumbed to the Deck Gun discharge outlet with 3" pipe terminating 3" FNPT x four-(4) bolt flange push-pull controlled at the pump operator's panel.

DISCHARGE, 2-1/2" LEFT REAR

One-(1) Akron 2-1/2" Heavy-Duty ball valve with 3/4" drain shall be plumbed to the left rear of the apparatus terminating 2-1/2" FNPT x 2-1/2" MNST with chrome cap and chain push-pull controlled at the pump operator's panel.

DISCHARGE, 2-1/2" RIGHT REAR

One-(1) Akron 2-1/2" Heavy-Duty ball valve with 3/4" drain shall be plumbed to the right rear of the apparatus terminating 2-1/2" FNPT x 2-1/2" MNST with chrome cap and chain push-pull controlled at the pump operator's panel.

WATER TANK

The tank shall have a capacity of 1000 U.S. gallons and shall be constructed of PT3™ polypropylene material. This material shall be a non-corrosive stress relieved thermoplastic and UV stabilized for

maximum protection. Tank shell thickness may vary depending on the application and may range from 1/2" to 1" as required. Internal baffles are generally 3/8" in thickness.

ISO CERTIFICATION

The tank must be "T" shaped in design and fabricated by a tank manufacturer that is ISO 9001:2008 certified in each of its locations. The ISO certification must be to the current standard in effect at the time of the design and fabrication of the tank.

DESIGN

Each tank is designed to the customer's specification and/or drawing submittal. An approval drawing is sent to the customer prior to commencing manufacturing. Upon receipt of the signed approval drawing, the tank is scheduled for production.

CONSTRUCTION

The booster and/or foam tank shall be of a specific configuration and is so designed to be completely independent of the body and compartments. Joints and seams shall be fused using nitrogen gas as required and tested for maximum strength and integrity. The tank construction shall include PolyProSeal™ technology wherein a sealant shall be installed between the plastic components prior to being fusion welded. This sealing method shall provide a liquid barrier offering leak protection in the event of a weld compromise. The top of the booster tank is fitted with removable lifting assembly designed to facilitate tank removal. The transverse and longitudinal swash partitions shall be manufactured of a minimum of 3/8" PT3™ polypropylene. All partitions shall be equipped with vent and air holes to permit movement of air and water between compartments. The partitions shall be designed to provide maximum water flow.

All swash partitions interlock with one another and are completely fused to each other as well as to the walls of the tank. All partitions and spacing shall comply with NFPA 1901. The walls shall be welded to the floor of the tank providing maximum strength as part of the tank's unique Full Floor Design™. Tolerances in design allow for a maximum variation of 1/8" on all dimensions.

WATER FILL TOWER AND COVER

The tank shall have a combination vent and manual fill tower. The fill tower shall be constructed of 1/2" PT3™ polypropylene and shall be a minimum dimension of 8" x 8" outer perimeter. The fill tower shall be blue in color indicating that it is a water-only fill tower. The tower shall be located in the left front corner of the tank unless otherwise specified by the tank manufacturer to the purchaser. The tower shall have a 1/4" thick removable polypropylene screen and a PT3™ polypropylene hinged cover. The capacity of the tank shall be engraved on the top of the fill tower lid. Inside the fill tower there shall be a combination vent/overflow pipe. The vent overflow shall be a minimum of schedule 40 polypropylene pipe with a minimum I.D. of 4" that is designed to run through the tank, and shall be piped to discharge water behind the rear wheels as required in NFPA 1901 so as to not interfere with rear tire traction. The tank cover shall be constructed of 1/2" thick PT3™ polypropylene and UV stabilized, to incorporate a multi-piece locking design, which allows for individual removal and inspection if necessary. The tank cover(s) shall be flush or recessed 3/8" from the top of the tank and shall be fused to the tank walls and longitudinal partitions for maximum integrity. Each one of the covers shall have hold downs consisting of 2" minimum polypropylene dowels spaced a maximum of 40" apart. These dowels shall extend through the covers and shall assist in keeping the covers rigid under fast filling conditions. A minimum of two lifting dowels shall accommodate the necessary lifting hardware.

SUMP

There shall be one (1) sump standard per tank. The sump shall be constructed of a minimum of 1/2" PT3™ polypropylene and be located in the left front quarter of the tank, unless specified otherwise. On all tanks that require a front suction, a 3" schedule 40 polypropylene pipe shall be installed that shall incorporate a dip tube from the front of the tank to the sump location. The sump shall have a minimum 3" NPT threaded outlet on the bottom for a drain plug per NFPA. This shall be used as a combination clean-out and drain. All tanks shall have an anti-swirl plate located approximately 3" above the inside floor.

OUTLETS

There shall be two (2) standard tank outlets: one for the tank-to-pump suction line, which shall be sized to provide adequate water flow to the pump; and, one for tank fill line, which shall be sized according to the NFPA minimum size chart for booster tanks. All tank fill couplings shall be backed with flow deflectors to break up the stream of water entering the tank, and be capable of withstanding sustained fill rates of up to 1000 GPM. The addition of rear suction fittings, nurse valve fittings, dump valve fittings, and through-the-tank sleeves to accommodate rear discharge piping must be specified. All auxiliary outlets and inlets must meet all NFPA guidelines in effect at the time of manufacture.

MOUNTING

The UPF Poly-Tank® III shall rest on the body cross members in conjunction with such additional cross members, spaced at a distance that would not allow for more than 530 square inches of unsupported area under the tank floor. In cases where overall height of the tank exceeds 40 inches, cross member spacing must be decreased to allow for not more than 400 square inches of unsupported area. The tank must be isolated from the cross members through the use of hard rubber strips with a minimum thickness and width dimension of 1/4" x 1" and a Shore A Hardness of approximately 60 durometer. The rubber must be installed so it shall not become dislodged during normal operation of the vehicle. Additionally, the tank must be supported around the entire bottom outside perimeter and captured both in the front and rear as well as side to side to prevent tank from shifting during vehicle operation. A picture frame type cradle mount with a minimum of 2" x 2" x 1/4" mild steel, stainless steel, or aluminum angle shall be provided or the use of corner angles having a minimum dimension of 4" x 4" x 1/4" by 6" high are permitted for the purpose of capturing the tank. Although the tank is designed on a free floating suspension principle, it is required that the tank have adequate vertical hold down restraints to minimize movement during vehicle operation. If proper retention has not been incorporated into the apparatus hose floor structure, an optional mounting restraint system shall be located on top of the tank, half way between the front and the rear on each side of the tank. These stops can be constructed of steel, stainless steel or aluminum angle having minimum dimensions of 3" x 3" x 1/4" and shall be approximately 6" to 12" long. These brackets must incorporate rubber isolating pads with a minimum thickness of 1/4" inch and a hardness of 60 durometer affixed on the underside of the angle. The angle should then be bolted to the body side walls of the vehicle while extending down to rest on the top outside edge of the upper side wall of the tank. Hose beds floors must be so designed that the floor slat supports extend full width from side wall to side wall and are not permitted to drop off the edge of the tank or in any way come in contact with the individual covers where a puncture could occur. Tank top must be capable of supporting loads up to 200 lbs. per sq. foot when evenly distributed. Other equipment such as generators, portable pumps, etc. must not be mounted directly to the tank top unless provisions have been designed into the Poly-Tank® III for that purpose. The tank shall be completely removable without disturbing or dismantling the apparatus structure.

CAPACITY CERTIFICATION

All water and foam tanks shall be tested and certified as to capacity on a calibrated and certified tilting scale. Each tank shall be weighed empty and full to provide precise fluid capacity. Each Poly-Tank® III

is delivered with a Certificate of Capacity delineating the weight empty and full and the resultant capacity based on weight. Engineering estimates for capacity calculations shall not be permitted for capacity certification.

TANKNOLOGY™ TAG

A tag shall be installed on the apparatus in a convenient location and contain pertinent information including a QR code readable by commercially available smart phones. The information contained on the tag shall include the capacity of the water and foam (s), the maximum fill and pressure rates, the serial number of the tank, the date of manufacture, the tank manufacturer, and contact information. The QR code shall allow the user to connect with the tank manufacturer for additional information and assistance.

WATER TANK SIZE CERTIFICATION

The manufacturer shall certify the capacity of the water tank prior to the delivery of the apparatus. This capacity shall be recorded on the manufacturer's record of construction and the certification shall be provided when the apparatus is delivered.

GAUGE, WATER LEVEL

A Fire Research TankVision Pro model WLA300-A00 tank indicator kit shall be installed on the pump operator's panel. The kit shall include an electronic indicator module, a pressure sensor, and a 10' sensor cable. The indicator shall show the volume of water in the tank on nine (9) easy to see super bright RGB LEDs. A wide view lens over the LEDs shall provide for a viewing angle of 180 degrees. The indicator case shall be waterproof, manufactured of Polycarbonate/Nylon material, and have a distinctive blue label.

The program features shall be accessed from the front of the indicator module. The program shall support self-diagnostics capabilities, self-calibration, six (6) programmable colored light patterns to display tank volume, adjustable brightness control levels and a datalink to connect remote indicators. Low water warnings shall include flashing LEDs at 1/4 tank, down chasing LEDs when the tank is almost empty, and an output for an audio alarm.

APPARATUS BODY, 96" WIDE

The 96" wide apparatus body and subframe shall be constructed entirely of marine grade aluminum plate and extrusions.

BODY SUBFRAME

The main body support cross member extrusions shall be 3" x 4" 6061T6 aluminum alloy, double "I" beam with a wall thickness of 7/16" (.438"). These cross members shall extend the full width of the body to support the compartment framing. The cross members shall be welded to a 3/4" (.750") x 3" solid aluminum, 6061T6 aluminum (alloy frame rail) extrusion. The frame rail extrusion shall be shaped in contour with the chassis frame rails. The frame rail extrusion shall be mounted over a 1/2" (.5") thickness, reinforced rubber cushion to isolate the aluminum subframe from the chassis steel frame rails. The apparatus body structure shall be securely fastened to the chassis frame rails with a minimum of six-(6) 5/8" (.625") cross member OD, steel U-bolts. The main body support cross member shall have a gusset above and below each cross member. The gussets shall be constructed of 2.0" x 4.0" 6063T6 aluminum alloy extrusion with a .190" wall thickness. The gussets shall be continuously welded with 5356 aluminum alloy welding wire to add support to the body sidewalls. The main body supports and the longitudinal double "I" beam supports shall have a "C" shaped rubber tank cushion installed on the top of each member. This rubber extrusion shall conform to the shape of the double "I" beam extrusion to keep the tank cushion in place. This method is used to prevent damage to the tank.

Absolutely no pop-rivets, screws or any other hardware shall be used to hold the rubber tank cushion in place.

BODY CONSTRUCTION

The complete apparatus body structure shall be an all welded construction and be free from nuts, bolts and other fasteners. Upon completion of the weldments, the body shall be completely sanded and deburred for removal of all sharp edges.

The body framework shall be formed from beveled aluminum alloy extrusions and electrically seam welded at each joint using 5356 aluminum alloy welding wire. Body sides shall be formed from 5052 H-32 (marine grade) smooth aluminum plates. The horizontal surfaces above the compartment tops shall be constructed from aluminum tread plate.

The horizontal and vertical frame member extrusions shall be 2.0" x 4.0" with a .190" wall thickness. The extrusion shall be made from 6063T6 aluminum alloy. This extrusion shall have .190" outside radius corners. The longitudinal frame member, below the lower compartments shall be a 2.0" x 4.0" 6063T6 aluminum alloy extrusion with .190" radius corners. Each body corner shall be a 3.5" x 9-3/4" 6063T6 extruded aluminum section with .210" wall thickness, and shall be welded as an integral part of the body. This extrusion shall have a 1" corner radius.

COMPARTMENT CONSTRUCTION

The compartment sidewalls shall be of one-piece construction. The walls shall be formed from 3/16" (.1875") 5052 H-32 (marine grade) smooth aluminum plate. All compartment floors shall be formed from 3/16" (.1875") aluminum tread plate. The floors shall be welded in place with a continuous weld all around the perimeter to insure maximum strength.

The external compartment tops shall be constructed of 1/8" (.125") aluminum tread plate. The tops shall have a formed edge, which serves as a drip rail for the compartments below. The compartment tops shall be secured with stainless steel screws to allow for ease of removal for access to the bodies wiring harnesses.

The compartment seams shall be sealed with permanent pliable silicone caulking.

Each compartment shall be vented through a 3" wide x 15" high louver that is machined stamped in a panel located in each body corner extrusion. The panel shall be removable to provide access to service wiring and other mounted components.

WHEEL WELL PANELS, ALUMINUM TREADPLATE

The wheel well shall be constructed from 2" x 4" x .190" wall thickness. The extrusion shall be made from 6063T6 aluminum alloy and have .190" outside radius corners. The extrusion shall be slotted the full length to permit an internal fit of 3/16" (.187") aluminum tread plate panels. The wheel well liners shall be constructed of 3003 H-14 smooth aluminum plates. They shall be bolted in place for ease of maintenance. The wheel well fenderettes shall be constructed of a #304 Stainless steel with a #7 polished finish.

A deflection shield shall be mounted to the body subframe to keep road debris from entering the water tank area.

HOSEBED

The hosebed sides shall be constructed of 3/16" (.1875") 5052 H-32 (marine grade) smooth aluminum plate welded to the extruded framework. There shall be a 3" x 3.5" 6063T6 aluminum extrusion with

.190" wall thickness running the entire length of the hosebed at the top for structural rigidity. The hosebed decking shall be constructed from anodized aluminum extrusions. The extrusions shall be 3/4" (.750") x 8.125" and have 3/4" (.750") x 3.00" hat channel attached to the underside to form a one-piece grid. The entire deck shall be removable, in one piece, to allow ease of serviceability to the tank. The hosebed shall include an extrusion across the front and rear of the compartment for the installation of adjustable hosebed dividers.

The fire apparatus hose body shall be 67-1/2" wide and shall contain a minimum of 79 cubic feet of storage.

COMPARTMENTS, LEFT SIDE

L1

There shall be one-(1) left front compartment installed ahead of the rear axle. This compartment shall have one-(1) roll up door. The compartment shall be approximately 43" wide x 64" high x 25" deep in the lower section and 12" deep in the upper section. The compartment shall have a useable door opening of approximately 40" wide x 51" high.

L2

There shall be one-(1) compartment installed above the wheel well. This compartment shall have one-(1) roll up door. The compartment shall be approximately 50" wide x 32" high x 12" deep. The compartment shall have a useable door opening of approximately 47" wide x 19" high.

L3

There shall be one-(1) left rear compartment installed behind the rear axle. This compartment shall have one-(1) roll up door. The compartment shall be approximately 36" wide x 64" high x transverse in the lower section and 12" deep in the upper section. The compartment shall have a useable door opening of approximately 33" wide x 51" high.

COMPARTMENT DOORS, LEFT SIDE ROLL UP

Roll-up doors shall be installed on the left side compartments of the apparatus as specified.

Slats are 1" double-wall (box frame) aluminum extrusion. Exterior surfaces are to be flat. Interior surfaces are to be concave to prevent loose equipment from jamming doors. The slats must be anodized to eliminate oxidation. The slats are to have inner-locking end shoes on every slat secured by a Punch-Dimple process. The slats are to have interlocking joints with a folding locking flange. Between each slat shall be a PVC/vinyl inner seal to prevent any metal-to-metal contact.

The track shall be one-piece aluminum, which has an attaching flange and finishing flange incorporated into its design, which provides a finish look to installation without additional trim or caulking. The track is to have a replaceable side seal. The side seal shall prevent water and dust intrusion into the compartment.

There shall be an aluminum drip rail above each compartment door with a built in replaceable wiper seal. Each roll up door shall have a counter balance to assist in lifting and eliminate the risk of accidental closing.

A full width lift bar, operable by one hand, shall be used as a positive latch device for securing each individual compartment door in the closed position.

The outside door shall have a natural finish.

There shall be an anodized aluminum sill plate installed over the compartment door.

COMPARTMENTS, RIGHT SIDE

R1

There shall be one-(1) right front compartment installed ahead of the rear axle. This compartment shall have one-(1) roll up door. The compartment shall be approximately 43" wide x 28" high x 25" deep. The compartment shall have a useable door opening of approximately 40" wide x 21" high.

R2

There shall be one-(1) right rear compartment installed behind the rear axle. This compartment shall have one-(1) roll up door. The compartment shall be approximately 36" wide x 28" high x transverse. The compartment shall have a useable door opening of approximately 33" wide x 21" high.

COMPARTMENT DOORS, RIGHT SIDE ROLL UP

Roll-up doors shall be installed on the right side compartments of the apparatus as specified.

Slats are 1" double-wall (box frame) aluminum extrusion. Exterior surfaces are to be flat. Interior surfaces are to be concave to prevent loose equipment from jamming doors. The slats must be anodized to eliminate oxidation. The slats are to have inner-locking end shoes on every slat secured by a Punch-Dimple process. The slats are to have interlocking joints with a folding locking flange. Between each slat shall be a PVC/vinyl inner seal to prevent any metal-to-metal contact.

The track shall be one-piece aluminum, which has an attaching flange and finishing flange incorporated into its design, which provides a finish look to installation without additional trim or caulking. The track is to have a replaceable side seal. The side seal shall prevent water and dust intrusion into the compartment.

There shall be an aluminum drip rail above each compartment door with a built in replaceable wiper seal. Each roll up door shall have a counter balance to assist in lifting and eliminate the risk of accidental closing.

A full width lift bar, operable by one hand, shall be used as a positive latch device for securing each individual compartment door in the closed position.

The outside door shall have a natural finish.

There shall be an anodized aluminum sill plate installed over the compartment door.

COMPARTMENT, CENTER REAR

B1

There shall be one-(1) compartment installed at the center rear of the apparatus. This compartment shall have one-(1) roll up door. The compartment shall have a useable door opening of approximately 43" wide x 21" high.

COMPARTMENT DOOR, REAR ROLL UP

A roll-up door shall be installed on the rear compartment of the apparatus.

Slats are 1" double-wall (box frame) aluminum extrusion. Exterior surfaces are to be flat. Interior surfaces are to be concave to prevent loose equipment from jamming doors. The slats must be anodized to eliminate oxidation. The slats are to have inner-locking end shoes on every slat secured by a Punch-Dimple process. The slats are to have interlocking joints with a folding locking flange. Between each slat shall be a PVC/vinyl inner seal to prevent any metal-to-metal contact.

The track shall be one-piece aluminum, which has an attaching flange and finishing flange incorporated into its design, which provides a finish look to installation without additional trim or caulking. The track

is to have a replaceable side seal. The side seal shall prevent water and dust intrusion into the compartment.

There shall be an aluminum drip rail above each compartment door with a built in replaceable wiper seal. Each roll up door shall have a counter balance to assist in lifting and eliminate the risk of accidental closing.

A full width lift bar, operable by one hand, shall be used as a positive latch device for securing each individual compartment door in the closed position.

The outside door shall have a natural finish.

There shall be an anodized aluminum sill plate installed over the compartment door.

REAR COMPARTMENT BLOUSE

There shall be an extension of the rear compartment between the beavertails to increase the lower compartment 8" in depth.

REAR BODY CONSTRUCTION, BEAVERTAILS

The rear of the apparatus shall be equipped with beavertails. The beavertails shall be constructed of 2" x 2" x .190" thickness, 6063T6 aluminum alloy extrusions with .190" radius corners. There shall be a removable panel on either side of the extrusion that is constructed of 1/8" (.125") aluminum tread plate.

VERTICAL LOAD TEST, APPARATUS BODY

The fire body shall exceed a vertical load testing. The vertical load test to the fire body shall follow the same strict and detailed requirements of the Economic Commission for Europe Structural Standard, ECE-29R as applied to the cab.

The fire body shall be placed under a vertical load test to show structural integrity. There shall be 65,979 lbs. (29.53 metric tons) applied to the fire body. There shall be no structure failures to the body and body compartments.

A complete photographic, video, data, and dimensional record of these tests shall be available and placed on record for customer evaluations.

BRACKETS, GROUND LADDERS

One-(1) pair of spring operated ladder brackets shall be installed on the exterior wall of the hosebed, right side, designed to hold one-(1) extension ladder and one-(1) roof ladder. Each bracket shall be mounted on polished aluminum extrusions slotted to allow infinite adjustment of the ladder brackets.

TRAYS, SUCTION HOSE

Two-(2) aluminum suction hose storage trays shall be installed, one-(1) each side above the body compartments. Each tray shall hold one-(1) 10' section of the specified suction hose and have spring latches to hold hose in position.

BODY TRIM

The standard body trim shall include the following:

There shall be drip rail installed over the compartment door openings.

A drip rail shall be located over each compartment door. This drip rail shall form a lip over the exterior door pans to prevent water from running into a compartment.

The vertical rear face of the body shall be covered with smooth aluminum plate.

Two-(2) handrails shall be located on the rear of the apparatus, one-(1) handrail per side. Each handrail shall be constructed of 1-1/4" knurled aluminum. The handrails shall be mounted with chrome plated end stanchions. Each handrail shall be sufficient in length to meet all standard requirements.

Two-(2) stanchions shall be mounted at the rear of the apparatus hosebed, one-(1) each side. The stanchions shall be 11" long x 3-3/4" wide. Stainless steel scuff plates shall be installed in the hosebed area to prevent deploying hose from damaged on stanchion supports. The stanchions shall provide mounting positions for the Zone C warning lights and additional hosebed lighting. All wiring for the upper rear lighting shall be concealed inside the stanchions.

FUEL FILL, RECESSED WITH DOOR

There shall be a recessed fuel fill assembly with a non-locking door mounted on the left side of the apparatus body. The fuel fill assembly shall be equipped with a fuel fill cap, retention ring and hinged door. The assembly shall be properly labeled "DIESEL FUEL ONLY".

MUD FLAPS, REAR

The rear axle mud flaps shall be constructed from hard black rubber and installed at the rear of the body fenders.

RUBRAIL

There shall be an aluminum rubrail installed on both sides of the lower body compartments. The rubrail shall be constructed from "C" channel extrusion. The aluminum rubrail shall be bolted in place with stainless steel bolts, and spaced from the fire body to provide body protection. The solid rubrail shall serve as protection to the side doors when encountering close objects. Tread plate rubrails or welded on shall not be acceptable.

REAR STEP

The 20" rear step shall be constructed with an anodized aluminum extrusion. This extrusion shall be slotted punched and raised to provide superior traction during wet and cold weather operations. The rear step shall be a two-piece design. The rear step shall bolt on with stainless steel nuts and bolts for replacement. The rear step shall have a space of approximately 1/4" from the rear of the body to allow water runoff.

All running board and step surfaces shall comply with NFPA 1901.

STEPS, REAR FIXED W/LED LIGHT

There shall be four (4) rear lighted steps installed on the apparatus. The steps shall be a Cast Products step and have a minimum of thirty-five (35) square inches of surface area to conform to the NFPA 1901 standards. The step(s) shall include a 12-volt LED light to illuminate the area below.

TOW EYES, REAR

Two-(2) 1" thick rear tow eyes constructed of A-36 steel shall be mounted below the frame at the rear of the vehicle. The tow eyes shall be attached to steel weldments that are mounted to the apparatus. The eyes shall have a minimum dimension of three-(3) inches. The tow eyes shall be used for towing, not lifting the vehicle.

HANDRAIL, BELOW HOSE BED

There shall be an intermediate handrail installed on the apparatus below the hose bed. The handrail shall be constructed of 1-1/4" knurled aluminum. The handrail shall be mounted with chrome plated end stanchions.

HOSE BED DIVIDER(S)

One (1) hose bed divider(s) shall be manufactured from 1/4" (.250") smooth aluminum plate with an extruded aluminum base welded to the bottom. The divider shall have an extruded track to slide in to allow the hose bed to adjust for different hose capacities. One end of the divider shall have a 3" radius corner. The divider shall be sanded to prevent damage to hose.

HOSE BED COVER

A hose bed cover constructed of 16 oz. heavy-duty Hypalon shall be provided. Cover shall be fire retardant and installed over hose bed. The cover shall have chrome twist-locks and Velcro installed around the perimeter of the hose bed. The end of the hose bed cover shall be secured and cover the hose bed opening. The cover shall completely protect the hose in the hosebed and prevent hose from inadvertently deploying during normal operation.

A safety sign FAMA22, which warns of the need to secure hose, shall be visible to personnel at the hose storage area.

The hypalon end flaps shall be secured at the bottom using snaps and Velcro. The end flaps shall completely protect the hose and prevent the hose from inadvertently deploying during normal operation.

The cover shall meet the TIA 03-1 NFPA requirement.

The covers shall be red in color.

SHELF, PERMANENT

There shall be two (2) permanent shelf (shelves) constructed from aluminum mounted in the specified location of the compartment. Each shelf shall have a 2" lip at the front and rear for additional strength.

ELECTRICAL SYSTEM

BODY ELECTRICAL

The body electrical system shall be designed as an integrated electrical package specifically engineered for fire apparatus application. The integrated electrical system shall be comprised of power distribution panels, which interface to the body and chassis through an engineered harnessing system.

All chassis wiring shall be type "GXL" in accordance with S.A.E. J1128 and NFPA-1901. Wiring shall be color coded and include function codes every three-(3) inches on both sides.

The electrical wiring harness shall be covered by a black split convoluted loom, rated at a minimum of 275° F.

DISTRIBUTION PANELS

The electrical distribution panels and circuits must be housed in each rear corner compartment or extrusion. The distribution panel shall incorporate a power and ground stud for connection to the internal circuits.

All internal wire end terminals, including locking bulkhead connectors, shall be mechanically affixed to the wire ends by machine terminal crimping presses. No hand-crimped terminals shall be acceptable.

All internal splices shall be ultrasonically welded connections - no butt style connections shall be acceptable. All internal wiring shall be of the high temperature GXL type wire and shall be protected by wiring duct wherever possible.

Each side electrical distribution panel shall consist of fifteen-(15) power distribution relays. The power distribution relays shall be replaceable, SPDT automotive style, rated at a minimum of 30 amperes.

The power distribution relays shall incorporate separate inputs, which are able to accept outputs from a load management system. The load management inputs must allow for the addition of a load management system before, during or after the time of delivery without requiring a rewiring of the existing distribution panel circuits.

Connections to the distribution panel shall utilize Deutsch style bulkhead connectors. Screw clamp type connections are not acceptable.

The distribution panel shall also contain circuit's ancillary to the required DOT signals and other body functions.

The complete body electrical system shall be 100% documented and contain independent circuit diagrams with point to point wiring information, as shall as a general component diagram included in the apparatus manual.

The body electrical panel shall be capable of being completely disconnected and fully tested by a computerized circuit analyzer.

All electrical equipment switches shall be mounted on a switch panel mounted in the cab convenient to the driver. Light switches shall be of the marine grade rocker type with integral indicator light to show when lights are energized. All switches shall be appropriately identified.

WIRING PROTECTION

All 12-volt wiring shall be run in high temperature, rated at a minimum of 275° F, split loom for easy access to wires when trouble shooting.

12-VOLT TESTING

The apparatus low voltage system shall be tested and certified. A copy of certification shall be provided to the purchaser with the apparatus.

Reserve Capacity Test

The unit shall be run until all engines, engine compartment temperatures are stabilized and the battery system is fully charged. The engine shall be shut off and the minimum continuous electrical load be activated for ten-(10) minutes. All electrical loads shall be shutoff after ten-(10) minutes and the battery system shall then be capable of restarting the engine.

Alternator Performance Test at Idle

Minimum continuous electrical loads shall be activated while the unit is at idle speed.

Alternator Performance Test at Full Load

The total continuous electrical load shall be activated with the engine running up to the manufacturer's governed speed. The test duration shall be a minimum of two-(2) hours. Activation of the load management system shall be permitted during the test. If however, an alarm is sounded by excessive battery discharge as detected by the system or a system voltage of less than 11.8 volts DC for a 12-volt nominal system for more than 120 seconds, shall be considered a test failure.

Low Voltage Alarm Test

The engine shall be shut off and the total continuous electrical load shall be activated and continue to be applied until the excessive battery discharge alarm activates. The test shall be considered a failure if the alarm has not sounded within 140 seconds after the voltage drops to 11.8 volts.

EMI/RFI PROTECTION

The apparatus shall be manufactured to incorporate the latest designs in the electrical system with components that are state of the art to insure electromagnetic interference (EMI) and radio frequency interference (RFI) emissions are suppressed at the source.

The apparatus shall have the ability to operate in typical fire and rescue situations with no adverse effects from EMI and/or RFI.

The apparatus shall utilize components that are fully protected and wiring that utilizes shielding and loop backgrounds where required to control EMI/RFI susceptibility. The apparatus shall be bonded through ground straps. Relays and solenoids that are suspect to generating spurious electromagnetic radiation are diode and/or resistor protected to prevent transient voltage spikes.

In order to prevent the radio frequency interference completely the purchaser shall be requested to provide a listing of the type, power output, and frequencies of all radio and bio medical equipment that is proposed to be used on the apparatus.

BACK-UP ALARM

There shall be one-(1) Whelen model WBUA107, 107 dB, electronic back-up alarm installed at the rear of the apparatus. The alarm shall be wired to the transmissions output signal and is automatically activated when the transmission is shifted into reverse.

LIGHTS, COMPARTMENT

Each compartment shall have one-(1) Truck Lite Model 80351, 5" diameter single bulb compartment light wired to the door ajar system activated when the door is in the open position.

DOOR AJAR SWITCHES

All apparatus body doors shall be provided with an auto door switch. These switches shall operate the compartment interior lights and activate the door ajar indicator on each side of apparatus body when the door is opened. There shall be a red door ajar light mounted in the cab, in view of the driver to indicate an unsecured door. There shall be a buzzer mounted in the cab that shall alert the driver.

LIGHTBAR, 72" WHELEN FREEDOM IV

A Whelen Edge Ultra Freedom IV Linear Super-LED LC Series 72" lightbar model F4N7QLED shall be provided. The F4N7QLED lightbar shall incorporate an anodized extruded heavy duty aluminum base and cover chassis with two front red corner modules with two red endcap modules, two interior white modules, and two interior red modules. The front of each corner module shall consist of 12 red Linear Super-LEDs installed on a conformal coated PCB board with a thermal pad/aluminum bracket heat sink assembly. The short red endcap Linear Super-LED lights shall incorporate six red Super-LED installed on a conformal coated PCB board with a thermal pad/aluminum bracket heat sink assembly. The long red interior Linear Super-LED lights shall incorporate 12 red Super-LED installed on a conformal coated PCB board with a thermal pad/aluminum bracket heat sink assembly. The long white interior Linear Super-LED lights shall incorporate 12 white Super-LEDs installed on a conformal coated PCB board with a thermal pad/aluminum bracket heat sink assembly. The all modules will utilize a Diamond Optix™ metalized reflector and two optic collimators. All electronic components shall be conformal coated to provide additional protection. The outer lens construction shall consist of two clear Uni-Dome top lenses with a clear center lens and utilize two liquid injection molded wiper seal dividers for maximum protection against environmental elements. Metal top shields installed on the Uni-Domes and center lens

shall provide protection from climatic conditions and provides passive solar radiation to direct heat away from internal components.

The F4N7QLED shall have an electronic LC I/O board. The solid state I/O board shall be microprocessor controlled. The I/O board shall have built-in reverse polarity protection and output-short protection. The I/O board shall have the ability to flash twenty two Super-LED warning lights. There shall be a data bank of 12 Scan-Lock™ flash patterns including steady burn with low power and cruise light functions. The cruise light function shall allow the user the four corner modules as marker courtesy lights. The F4N7QLED will have the capability to install a traffic advisor in the rear of the lightbar. The I/O board shall also have outputs to add takedown, alley lights, and auxiliary lights for each set of lights to be controlled in pairs.

All lighthoods shall be installed in the F4N7QLED with the aid of black polycarbonate snap-in mounting brackets. The solid state lightbar shall be vibration resistant. The lightbar will contain a 17' 2/c 8GA unterminated power cable and 17' 17/c 22GA unterminated control cable. All electronic components are covered by a five year factory warranty. The F4N7QLED shall include a permanent mount kit with hardware.

The lightbar shall be controlled in the following manner:

Calling for Right of Way - All Positions
Blocking Right of Way - Clear shall not be Active

The lights shall be activated by a single emergency light switch located on the master light switch panel in the cab.

The lightbar shall meet NFPA 1901 edition as configured.

LIGHTS, ZONE C UPPER

Two- (2) Whelen model L31HRFN LED beacons shall be installed, one-(1) each side on the upper rear of the apparatus. Each light consists of four-(4) red Linear Super LED's.

The lights shall be red with red lens.

LIGHTS, ZONE B/D FRONT LOWER

Two-(2) Whelen LINZ6 Series Super-LED model LINZ6R lights shall be installed, one-(1) each side forward portion of the apparatus. The warning light shall incorporate six red Super-LEDs, a clear non-optic hard coated polycarbonate lens, clear optic collimator and utilize a metalized reflector for maximum output. The hard coated lens shall provide extended life/luster protection against UV and chemical stresses. The encapsulated lens/reflector assembly and conformal coated PC board shall provide additional protection against environmental elements. The solid state warning lights shall be vibration resistant. The self-contained flashing light shall have 69 Scan-Lock flash patterns including synchronize feature and steady burn. The warning light is covered by a five year factory warranty. The surface mount module includes a black flange and hardware for horizontal mounting.

LIGHTS, ZONE B/D MIDSHIP LOWER

Two-(2) Whelen LINZ6 Series Super-LED model LINZ6R lights shall be installed, one-(1) each side midship of the apparatus. The warning light shall incorporate six red Super-LEDs, a clear non-optic hard coated polycarbonate lens, clear optic collimator and utilize a metalized reflector for maximum output. The hard coated lens shall provide extended life/luster protection against UV and chemical stresses. The encapsulated lens/reflector assembly and conformal coated PC board shall provide additional protection against environmental elements. The solid state warning lights shall be vibration resistant. The self-

contained flashing light shall have 69 Scan-Lock flash patterns including synchronize feature and steady burn. The warning light is covered by a five year factory warranty. The surface mount module includes a black flange and hardware for horizontal mounting.

LIGHTS, ZONE B/D REAR LOWER

Two-(2) Whelen LINZ6 Series Super-LED model LINZ6R lights shall be installed, one-(1) each side rearward portion of the apparatus. The warning light shall incorporate six red Super-LEDs, a clear non-optic hard coated polycarbonate lens, clear optic collimator and utilize a metalized reflector for maximum output. The hard coated lens shall provide extended life/luster protection against UV and chemical stresses. The encapsulated lens/reflector assembly and conformal coated PC board shall provide additional protection against environmental elements. The solid state warning lights shall be vibration resistant. The self-contained flashing light shall have 69 Scan-Lock flash patterns including synchronize feature and steady burn. The warning light is covered by a five year factory warranty. The surface mount module includes a black flange and hardware for horizontal mounting.

LIGHTS, ZONE C LOWER

Two-(2) Whelen 600 Series Super-LED model 60R02FRR shall be installed, one-(1) each side on the lower rear of the apparatus. The warning light shall incorporate red Linear Super-LEDs, a red optic hard coated polycarbonate lens, and utilize a metalized reflector with integrated TIR hybrid optics for maximum output. The hard coated lens shall provide extended life/luster protection against UV and chemical stresses. The encapsulated lens/reflector assembly and conformal coated PC board shall provide additional protection against environmental elements. The solid state warning lights shall be vibration resistant. The self-contained flashing light shall have 14 Scan-Lock flash patterns including synchronize feature and steady burn. The warning light is covered by a five year factory warranty.

STOP, TURN AND BACK-UP LIGHTS

Stop, turn and backup lights shall be Whelen Model 64 individual fixtures with halogen lamps. The red stop light shall be model 60X000RR, the turn light shall be a model 60X000TR amber type with directional arrow, and the backup light shall be a model 60F000CR clear flood light type.

HOUSING, REAR TAIL LIGHT ASSEMBLY

The fixtures shall be mounted on each rear face of the body in a model CAST4, four-(4) lighthouse cast aluminum housing.

LIGHTS, SWIVEL MOUNT DECK

Two-(2) 6" chrome plated deck lights with swivel mount shall be installed one-(1) each side at the rear of the apparatus. Each light shall be manually operated and switched on and off at the light. One-(1) halogen spot light bulb with 160,000-candlepower shall be supplied. One-(1) halogen flood light bulb with a 6,000 candlepower shall be supplied.

The deck lights shall also serve as rear work lights to illuminate the rear of the apparatus to meet NFPA-1901 requirements.

CLEARANCE LIGHTS AND REFLECTORS

Clearance lights and reflectors shall be LED lights, which include (2) red marker lights, (4) red rectangular reflectors, (2) amber rectangular reflectors and (1) red three light cluster recessed in the rear step.

LIGHT, LICENSE PLATE

A Whelen OS Series LED model 0SC0EDCR shall be provided at the rear of the apparatus to illuminate the license plate. The steady burn illumination light shall incorporate three clear LED and a clear non-optic hard coated polycarbonate lens. The hard coated lens shall provide extended life/luster protection

against UV and chemical stresses. The encapsulated assembly shall provide protection against environmental elements. The solid state illumination light shall be vibration resistant. An installation kit including mounting hardware, neoprene gasket and 45 degree angle chrome housing shall be provided for surface mounting. The 0AC0EDCR will contain a 12" non-terminated pigtail. The illumination light meets SAE J592 requirements and is covered by a five year factory warranty.

BODY PAINT FINISH, SINGLE COLOR

The body exterior shall have no mounted components prior to painting to assure full coverage of metal treatments. Box pan compartment doors shall be painted separately to assure proper paint coverage on body, doorjamb, and door edges.

All painted surfaces shall follow the following procedure to insure a lasting finish:

- Metal surfaces shall be sanded to remove all burrs and imperfections, before etching and treatment.
- A wax & grease solvent shall be used to clean and prep the aluminum surface. The surface shall then be rinsed with fresh water. This step removes wax, grease and other surface contaminants, thus leaving a bright, clean, and conditioned surface.
- A self-etching, metal primer shall be applied next. The self-etching primer shall fill all of the minor imperfections, scratches, etc. in the metal. This step produces a corrosion resisting conversion coating that prevents off oxidation and other surface contaminants leaving a surface that gives excellent paint adhesion.
- A sandable primer shall be sprayed on the metal that seals the surface for the polyurethane paint. A minimum coating thickness of 2 MIL shall be applied. Primer is then sanded smooth leaving the best surface for topcoat.
- The apparatus body shall then be painted with a minimum of three-(3) coats of color.

These steps are followed as recommended by the paint manufacturer to provide a lasting and high quality gloss finish. DuPont shall provide all paint products.

BODY PAINT COLOR/CODE

The apparatus body paint code shall be Red, B8241EW.

INTERIOR COMPARTMENT FINISH

The interior of the body compartments shall be a natural finish.

SCOTCHLITE STRIPE

There shall be a 4" wide Scotchlite stripe located on the apparatus cab and body. The stripe shall cover a minimum of fifty percent (50%) of the cab, body sides and of the rear of the apparatus. The stripe shall also cover twenty-five percent (25%) of the front of the apparatus. The stripe shall be installed to meet the current NFPA requirements.

The striping shall be white in color.

The reflective stripe shall run straight from the headlights to the rear of the body on each side of the apparatus.

STRIPE, REAR CHEVERON

A minimum of fifty percent of the rear vertical surface of the unit shall be overlaid with a reflective material, installed in an alternating "Chevron" pattern (sloping down and away from the centerline) at a 45-degree angle. Each stripe shall be 6" wide and the colors of striping shall be in compliance, with the current edition of NFPA 1901.

The Chevron striping shall be 3M red and lime green.

LETTERING

There shall be a maximum of sixty (60) 3" tall Spun Gold letters applied to the apparatus. The lettering shall also have a one color shade applied.

The lettering shall be gold in color.

The shade shall be black in color.

WARRANTY, BODY PARTS & LABOR

There shall be a two-(2) year body mechanical parts and labor warranty provided with the apparatus. The apparatus shall be free of defects in material and workmanship for a warranty period of two-(2) year after the date on which the apparatus is first delivered to the original purchaser.

WARRANTY, CAB/CHASSIS PARTS & LABOR

The manufacturer shall provide a limited parts and labor warranty to the purchaser of the cab and chassis for a period of one-(1) year, or the first 12,000 miles, whichever occurs first. The warranty period shall commence on the date the vehicle is delivered to the end user.

WARRANTY, CAB STRUCTURAL

The cab structure shall be warranted for a period of ten-(10) years or one hundred thousand (100,000) miles which ever may occur first. The warranty period shall commence on the date the vehicle is delivered to the end user.

WARRANTY, BODY STRUCTURAL

There shall be a ten-(10) year body warranty on each new fire body/heavy-duty rescue apparatus. The bodies are to be free of structural failures caused by defective design or workmanship for a warranty period of ten-(10) years after the date on which the vehicle is first delivered to the original purchaser or 100,000 miles, whichever occurs first.

WARRANTY, BODY PAINT/CORROSION

There shall be a four-(4) year paint/corrosion warranty provided. This warranty shall cover perforation, blistering, peeling, or any other adhesion defects caused by defective manufacturing methods, or material selections, for a warranty period of four-(4) years or 100,000 miles which occurs first, after the date of which the vehicle is first delivered to the original purchaser.

WARRANTY, FRAME RAIL

The chassis frame and crossmembers shall be provided with a lifetime material and workmanship limited warranty to the original purchaser. The warranty shall cover the chassis frame and crossmembers as being free from defects in material and workmanship that would arise under normal use and service.

Proposals offering warranties for frames not including cross members shall not be considered.

WARRANTY, MERITOR AXLE

FRONT AXLE

The front axle shall be warranted by Meritor for two-(2) years with unlimited miles under the general service application.

REAR AXLE

The rear axle shall be warranted by Meritor for two-(2) years with unlimited miles under the general service application.

WARRANTY, DIESEL ENGINE

The Cummins engine shall be warranted for a period of five-(5) years or 100,000 miles, whichever occurs first.

WARRANTY, TRANSMISSION

The Allison EVS series transmission shall be warranted for a period of five-(5) years with unlimited mileage. Parts and labor shall be included in the warranty.

WARRANTY, ANTI LOCK BRAKE SYSTEM

The ABS brake system shall be warranted for a period of three-(3) years/300,000 miles.

WARRANTY, HALE FIRE PUMP

EXPRESS WARRANTY

Hale Products, Incorporated ("Hale") hereby warrants to the original buyer that products manufactured by Hale are free of defects in material and workmanship for a period of five-(5) years from the date the product is first placed into service or five and one-half (5-1/2) years from date of shipment by Hale, whichever period shall be first to expire. Within this warranty period Hale will cover parts and labor for the first two-(2) years and parts only for years three (3) through five (5).

LIMITATIONS

HALE'S obligation is expressly conditioned on the Product being:

- Subjected to normal use and service
- Properly installed and maintained in accordance with HALE'S Instruction Manual and Industry Standards as to recommended service and procedures
- Not damaged due to abuse, misuse, negligence, or accidental causes
- Not altered, modified, serviced (non-routine), or repaired other than by an Authorized Service facility
- Manufactured per design and specifications submitted by the original buyer
- Used with an appropriate engine as determined by the engine manufacturers published data
- Excluded are normal wear items identified as but not limited to packing, strainers, anodes, filters, light bulbs, intake screens, wear rings, mechanical seals, etc.

WARRANTY, PLUMBING SYSTEM

There shall be a ten-(10) year pump plumbing warranty provided. The warranty covers all plumbing components used in construction of the fire apparatus water/foam plumbing system against defects and workmanship, provided the apparatus is used in a normal and reasonable manner. The warranty is extended only to the original user-purchaser for a period of 10 years from the date of delivery.

WARRANTY, WATER TANK

The poly tank manufacturer warrants each tank to be free from manufacturing defects in material and workmanship for the service life of the original vehicle (vehicle must be actively used in fire suppression). The warrant is transferable, with written approval of the manufacturer. Each tank is inspected and tested for leaks prior to leaving the manufacturing facility. The tank shall be installed in the vehicle in accordance to the manufacture's guidelines.

There are no warranties, expressed or implied, which extend beyond the description of the face hereof. There is no expressed or implied warranty of merchantability or a warranty of fitness for a particular purpose. Additional, this warranty is in lieu of all other obligations or liabilities on the part of the Manufacturer.

MANUAL, CHASSIS OPERATION

There shall be two-(2) digital copies of the chassis operation manual provided with the chassis. The digital data shall include a parts list specific to the chassis model.

MANUALS, ENGINE AND TRANSMISSION OPERATION

There shall be two-(2) printed hard copy sets of the engine operation manual and two-(2) printed hard copy sets of the transmission operation manual specific to the model ordered included with the chassis.

MANUALS, APPARATUS BODY

The contractor shall supply, at time of delivery, at two-(2) sets of complete operation and service documentation covering the completed apparatus as delivered and accepted.

The documentation shall address at least the inspection, service, and operations of the fire apparatus and all major components thereof.

MANUALS, FIRE PUMP

There shall be two-(2) copies of pump manuals provided to the department.

SAFETY GUIDE

One-(1) copy of the latest edition of FAMA's Fire Apparatus Safety Guide shall be provided with the completed apparatus.

WIRING DIAGRAMS, CAB/CHASSIS

There will be a complete digital set of electrical schematics provided at the time of delivery. These schematics will have each circuit properly numbered and in color.

The schematic will show each connector in the circuitry and the position in which each circuit enters, exits, or terminates. The schematic will be drawn in such a manner as to allow individual circuitry to be followed throughout the apparatus.

These schematics will not have the circuitry condensed into a single line or sets of lines. Multiple sheets will be acceptable so long as each of the harnesses is properly identified to the connecting sheet and harness. There will be a border around the paper(s), which contain alpha and numeric characters for indexing coordinate reference. There will be an indexing or part reference document for quick location of items shown on the schematics.

WIRING DIAGRAMS, APPARATUS BODY

There will be a complete set of generic electrical schematics provided at the time of delivery. These schematics will have each circuit properly numbered and in color.

The schematic will show each connector in the circuitry and the position in which each circuit enters, exits, or terminates. The schematic will be drawn in such a manner as to allow individual circuitry to be followed throughout the apparatus.

These schematics will not have the circuitry condensed into a single line or sets of lines. Multiple sheets will be acceptable so long as each of the harnesses is properly identified to the connecting sheet and harness. There will be a border around the paper(s), which contain alpha and numeric characters for indexing coordinate reference. There will be an indexing or part reference document for quick location of items shown on the schematics.

This document will refer the user to the appropriate drawing and page number and to sections of the drawing(s) by the means of letter and number coordinates. The schematic will show all harnesses used in the apparatus cab, chassis and body that is supplied by the chassis and body manufacturer.

Modifications to the manufactured standard harnesses are to be documented and properly indexed for quick identification.

A complete wire number, color, and function listing will accompany the schematics.

NFPA REQUIRED EQUIPMENT, FD SUPPLIED

The loose equipment as outlined in NFPA 1901, 2009 edition, section 5.7.1 and 5.8.3 shall be provided by the fire department unless it is listed in this proposal. All loose equipment shall be installed on the apparatus before placed in emergency service, unless the fire department waives NFPA section 4.21.

LADDER(S), 10' FOLDING

There shall be one (1) Alco-Lite Model FL-10, 10' folding ladder(s) provided with the apparatus. The ladder(s) shall be aluminum, single-section with rubber feet. The ladder(s) shall meet or exceed the latest NFPA standards.

BRACKETS, ATTIC LADDER

Ziamatic model FLBA attic ladder brackets with aluminum stirrup shall be installed on the right side, designed to hold one-(1) Alco-Lite folding attic ladder.

LADDER(S), 14' ROOF

There shall be one (1) Alco-Lite model PRL-14, 14' roof ladder(s) supplied with the apparatus. The ladder(s) shall be aluminum, single-section with folding steel roof hooks on one end and steel spikes at the other. The ladder(s) shall meet or exceed the latest NFPA standards.

LADDER(S), 24' 2-SECTION EXTENSION

There shall be one (1) Alco-Lite model PEL-24, 24' two-section ladder(s) supplied with the apparatus. The extension ladder(s) shall be aluminum with steel spurs on one end. The ladder(s) shall meet or exceed the latest NFPA standards.

SUCTION HOSE, 6"

There shall be two-(2) 10' x 6" sections of Kochek PVC flexible suction hose supplied with the apparatus. Lightweight aluminum couplings shall be provided on the suction hose. A long handle female swivel shall be provided on one end and a rocker lug male shall be provided for the other end.

STRAINER, 6" BARREL

There shall be one-(1) Kochek BS60C, 6" chrome plated barrel strainer supplied with the apparatus. The strainer shall have a 6" NH female connection.

30 DEGREE ELBOW(S) - 2-1/2" FNST X 2-1/2" MNST

There shall be one (1) Trident model 01.010.0 2-1/2" FNST x 2-1/2" MNST chrome plated elbow(s) supplied with the apparatus. The elbow(s) shall have a 30 degree turn down.

BRACKET(S), AIR PACK W/STRAP

There shall be five (5) Ziamatic Model ULLH air pack bracket(s) with strap (part number 1054-012-000) installed on the apparatus as specified by the Fire Department. The bracket(s) shall meet NFPA 1901.

Superliner



Perfection in Design.

The 167" Body Length Superliner with an optional 171" Body Length, features a Ford E450 Chassis with 158" Wheelbase or GM G4500 Chassis with 159" Wheelbase.

With numerous standards, including:

- ◆ 72" Headroom
- ◆ Back-Up Camera, Utilizes Front Monitor when activated
- ◆ Momentary Disable Switch for Right Side Scene Lights
- ◆ Power Door Locks on Entry Doors
- ◆ Exterior Emergency LED Lighting
- ◆ Patient Area LED Lighting
- ◆ Exterior Compartment LED Lighting
- ◆ Stainless Steel threshold protectors
- ◆ Vortex Lined (Polyurea) Interior of Exterior Compartments providing an easy to clean as well as a durable, no crack no peel & no slip surface
- ◆ Stainless Steel Venting in all compartments

Imagine the kind of ambulance interior you might get if you took the great ideas from experienced EMT's and committed industry's leading designers and craftsmen to make them happen...

Open the door to a Life Line Emergency Vehicle and that's exactly what you'll find.

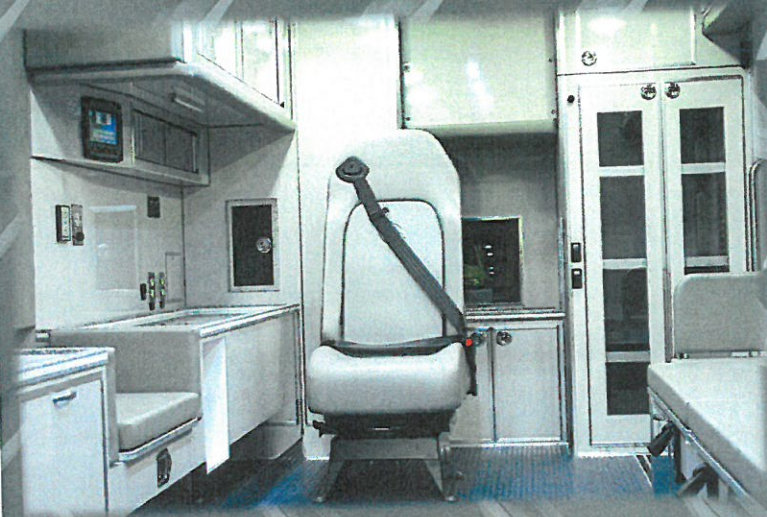

Life Line
EMERGENCY VEHICLES

P.O. Box 299 - Sumner, IA 50674 - www.lifelineambulance.co
563-578-3317 - 563-578-3305 (fax)



QUOTATION

9-9-2016

Jamestown Fire Department
 Howard Tighe Asst. Chief
 50 Narraganset Ave
 Jamestown, R. I. 02835
 401-423-0063 X 103
 htighe@jamestownfd.com

SPECIALTY VEHICLES, INC.
 Al Hooper
 58 George Leven Drive
 North Attleboro, MA 02760
 508-699-0616
 508-699-0977
 ahooper@svine.com

Exp. Date: 10/08/2016
Quote No: 10141-0002
BODY: SUPER B 167" SUPERLINER TYPE III

09/09/2016

Page 1

PART NO	DESCRIPTION	QTY
	== 167" SUPERLINER TYPE III - 1.000 10/05/16 ==	1
	MASTER PARTS REVISION DATE (Start 07-06-16 to 10-05-16)	1
00-00-0500	< LIFE LINE WARRANTY SHOP NOTE: Warranties Include: Lifetime Modular Body Warranty Lifetime Electrical Harness Warranty Lifetime Limited Cabinet Warranty 5-Year/60,000 Mile Product Conversion Warranty 10-Year/100,000 Mile Electrical Warranty Elite System 6-Year Pro-Rated DuPont Paint Warranty Which is as follows: For 3 Years 100% 4th Year 50% 5th Year 25% 6th Year 10%	1
00-00-0700	< >>>SHOP COPY DATE - FACTORY USE ONLY<<< SHOP NOTE: Date Order Placed By Dealer: Draft Work Order Process Date: 1st Dealer Draft Date: Final Dealer Draft Date: Sign-Off Date: Parts/Drafting/Paint: Shop Release Date: SFD:	1

PART NO	DESCRIPTION	QTY
00-00-0800	< Customer Contact Person (Required For Factory Use) SHOP NOTE: Specify Name And Number: Jamestown Fire Department 50 Narraganset Ave Jamestown, R. I. 02835 Howard Tighe Asst Chief 401-423-0062 X 103	1
00-00-2800	< Sales Rep: Al Hooper 1-508-699-0616 SHOP NOTE: Specialty Vehicles, Inc.	1
00-00-FL00	Fill Unit With Fuel For Delivery (Charge To Dealer Account)	1
00-00-FN00	< Specify FORD Fleet Number If Available (FORD Chassis Only) SHOP NOTE: Specify FIN Number: QE229 NOTE: THIS ORDER IS BASED OFF #299610SD	1
00-00-PU00	< Specify Previous Unit Number: (FACTORY USE ONLY) SHOP NOTE: #299610SD	1
00-00-W300	Life Line Work Order Contact Person - Steve Jacobson ***BODY STYLE***	1 1
00-01-3000	< 167" x 96" SUPERLINER TYPE III BODY (WIDE AISLE) SHOP NOTE: With Wide Aisle Width. ***CHASSIS***	1
10-00-0100	Chassis VIN Number: (FACTORY USE ONLY)	1
10-00-1501	< 2017 Ford E-450 SD Cutaway Van (Gas V10 Engine) SHOP NOTE: With Standard Ford O.E.M. 3-Year/36,000 Mile Warranty. Includes Rubber Floor As Standard.	1
10-01-3400	< **FACTORY USE ONLY** SHOP NOTE: Spare Chassis Keys And Owner's Manual Present.	1
10-01-5500	IPD/Roadmaster Rear Sway Bar	1
10-01-7500	< Real Wheels Stainless Steel Wheel Covers SHOP NOTE: Includes Air Max Valve Extenders.	1
10-01-9500	Ship The Spare Tire Loose	1
10-02-1100	< E-Series O.E.M. Door Mirrors SHOP NOTE: Dual Powered Trailer Tow Mirrors.	1
10-02-3500	O.E.M. AM-FM/CD Radio W/Cab Speakers	1
10-02-5000	Low Voltage Throttle Manager	1
10-02-5700	< Hand Held Cab Spot Light SHOP NOTE: Ship Vortex Box Loose For Dealer Install	1

PART NO	DESCRIPTION	QTY
10-02-6500	< E-Series Molded Console With Added Map Box Storage Area SHOP NOTE: Adds Medium Floor Mounted Map Box Storage To Engine Cover Console. Solid Top On Map Box. Box Dimensions 9" High X 12" Long X 12" Wide Same As Last #299610SD (See Drawings)	1
10-03-6100	< Pre-Wire For Tire Chain System SHOP NOTE: Specify Switch Location: Loose In Front Console (Switch Included). Specify Pre-Wire Location: D-2 Compartment Wall #1 NOT AVAILABLE WITH DUAL FUEL TANKS ON AN F-SERIES CHASSIS	1
10-03-9000	< Add Third Battery-Matched CCA Of The Standard Batteries SHOP NOTE: Specify Mounting Location:	1
10-04-1600	< Custom S.V.I. Battery Tray Option For 3 Deka Batteries SHOP NOTE: Battery Tray To Be Sized For 3 Deka #DC31DT Batteries. Each Battery Is 13" Long x 6.5" Wide x 9.5" High. Requires 1" Taller Battery Compartment ILOS. (Dealer Will Install Batteries After Delivery). NOTE- DO NOT USE INTERSTATE BATTERYS.	1
10-04-3500	Owner's Manual (1 Included With Unit)	1
10-04-8600	< S.V.I. Whelen 2" Round 5mm LED Cab Warning Lights (Pr) SHOP NOTE: (1) Whelen PAR16 Red LED Mounted On The Cab Roof Liner. Flashing Light To Indicate Open Compartment/Entry Doors. (Surface Mount Chrome Flange Mount TFLANGEC). (1) Whelen PAR16 Amber LED Mounted On The Cab Roof Liner. Flashing Light To Indicate The Parking Brake Is Applied When The Unit Is Placed Into A Drive Gear. (Surface Mount Chrome Flange Mount TFLANGEC). Both Mounted Between The O.E.M. Visors. Label Each Light For Function: "OPEN DOOR" "EMERGENCY BRAKE APPLIED" Stainless Steel With Black Letters.	1
10-DL-0100	< C Better Mirrors SHOP NOTE: Specify Custom Option:	1
	MODULAR BODY TYPE III	1
15-01-1600	< KKK Package SHOP NOTE: Includes (2)-5# Fire Extinguishers Oxygen Wrench Lock on Cab to Module Door or Window, lockable from cab side	1

PART NO	DESCRIPTION	QTY
15-01-5000	Standard 72" Finished Headroom	1
15-01-6500	< Bulkhead Wall Recessed Additional 3" SHOP NOTE: With A Total Of 6" Recessed Area.	1
15-01-9000	< Delete Standard Cab To Module Sliding Door SHOP NOTE: Will Be A Pass-Thru	1
15-01-9005	Cab To Module Sliding Pass-Thru Window	1
15-01-9005	Cab To Module Sliding Pass-Thru Window	1
15-02-0500	C.P.I. # VC0004-1 Vents (3 STD)	1
15-02-1600	< 1 Piece Stainless Steel Wheel Well Trim Rings (Small) SHOP NOTE: 18.75" radius for Ford E-Series/F-Series, Dodge, Chevy G-Series, CK and TerraStar	1
15-02-2500	Standard Cast Fuel Fill Housing ***MODULE DOORS AND WINDOWS***	1 1
20-00-0100	< 2 Red Reflectors On Each Module Entry Door SHOP NOTE: One Mounted At The Top And One Mounted At The Bottom.	1
20-00-0500	< Combination Extruded/Pan Formed Module Entry Doors SHOP NOTE: With Clean Seal #50512 Door Gaskets. Includes Stainless Steel Sill Plates. Non-Slip Tape on Side Entry Sill Plate	1
20-01-0000	< Full Height Side Entry Door With Gas Style Hold-Open SHOP NOTE: Position The Hold-Open At 90 Degrees.	1
20-01-1000	Side Entry Door Threshold With Non-Slip Tape	1
20-01-1900	< Fixed Side Entry Door Window (Bronze Tint) SHOP NOTE: With Bronze Tint Option.	1
20-01-3500	Rear Doors With Grabber Style Hold-Opens	1
20-01-5400	< Fixed Rear Entry Door Windows (Bronze Tint) SHOP NOTE: With Bronze Tint Option.	1
20-01-9000	< Delete Exterior Assist Handle On Side Or Rear Entry Doors (Ea) SHOP NOTE: Specify Deletion Location: Side And Rear Doors	3
20-02-0000	Tri-Mark 030-18 Free Float Handles with Chrome Exterior And Black Pocket	1
20-02-1500	Secondary Exterior & Interior Rear Door Paddle Latch Standard	1
20-02-2500	Shielded Cable Activated Module/Compartment Door Latches	1
20-02-3500	Cage Nuts On All Door Panels	1
20-02-4000	Polished Diamond Plate Lower Module Entry Door Trim Panels	1
20-02-5500	< Stainless Trim On Hinge Side Of Door Extrusions (Ea) SHOP NOTE: Specify Location: P-1, P-3, P-4, R-1 X 2, R-1 Both Doors, D-1, D-2 X 2, D-3 x 2,	13
20-02-6000	< Diamond Plate Side Entry Door Stepwell W/Sealed Seam Edges SHOP NOTE: Left Side Of StepWell Area For Portable Oxygen Storage	1

PART NO	DESCRIPTION	QTY
20-03-0700	< Window In Side Of Body (Bronze Tint) SHOP NOTE: With Bronze Tint Option.	1
20-03-3000	< Two Section Privacy Panel With Marker Board SHOP NOTE: Drawings To Indicate Standard Or Custom Two Section Panel.	1
EXTERIOR COMPARTMENTS		1
25-00-0100	< SPECIAL NOTE TO DEALER SHOP NOTE: Custom Compartment Options/Designs Not Listed In The Published Options List MAY Result In Additional Charges.	1
25-00-0200	< 2 Red Reflectors On Each Full Height Compartment Door SHOP NOTE: One Mounted At The Top And One Mounted At The Bottom. One Reflector Mounted On Each Standard Height Compartment Door.	1
25-00-0500	< Combination Extruded/Pan Formed Compartment Doors SHOP NOTE: With Clean Seal #50512 Door Gaskets And Stainless Steel Sill Plates. Includes Gas Style Hold-Opens Unless Otherwise Noted. Special Note To Production: Position All Gas Hold-Opens For Maximum Allowable Door Opening. Does Not Include Doors That May Hit Other Compartment Doors.	1
25-00-0600	Polished Diamond Plate Exterior Compartment Door Panels	1
25-01-0000	Magnetic Compartment Door Switches	1
25-01-1000	< Polyurethane Compartment Lining-Standard Gray SHOP NOTE: Standard Gray	1
25-01-2500	< Standard TecNiq Model E410 LED Strip Lighting Surface Mounted Compartment Lights SHOP NOTE: One Strip To Be Installed Vertically Inside Door Frame Against Wall #1 Or #3 As The Standard. The Standard Light Lengths Used Are: 18" E22140 31.5" E22141 54" E22145 72" E22149	1
25-01-3220	< 18" TecNiq Model E410 LED Strip Lighting IATS For Exterior Compartment (Ea) SHOP NOTE: Specify Location(s): In The ceiling Of; D-1, D-2, D-3, P-4	4
25-01-3224	< 31.5" TecNiq Model E410 LED Strip Lighting IATS For Exterior Compartment (Ea) SHOP NOTE: Specify Location(s): Door Opening D-2, D-3 Compartments	2
25-01-3226	< 72" TecNiq Model E410 LED Strip Lighting IATS For Exterior Compartment (Ea) SHOP NOTE: Specify Location(s): Door Opening D-1, P-4 Compartments.	2

PART NO	DESCRIPTION	QTY
25-01-3300	Stainless Steel Compartment Vents	1
25-04-3000	< Delete Superliner Curbside Front Backboard Compartment SHOP NOTE: Specify Alternate Backboard Compartment: P-4	1
25-04-5100	< Move Superliner IS/OS And Side Entry Door Forward SHOP NOTE: Full Height 19.5" Pass-Thru Width I S / OS Compartment P-1 Compartment	1
25-04-6500	< Aluminum Adjustable IS/OS Compartment Shelf (Ea) SHOP NOTE: Specify Diamond Plate Or Smooth Aluminum Shelves: Includes Rubber Mat. Specify Lip Size: 1'5" (1) Upper Section (2) Lower Section	3
25-04-7500	< Vortex Lined Walls In IS/OS Compartment SHOP NOTE: Specify Color: Std. Lt. Gray	1
25-04-8000	< Superliner Curbside Front Battery Compartment SHOP NOTE: Sized For (3) Oversized Deka Batteries Bottom Hinged Door Install A 1" Nylon Seat Belt Strap With Metal Clip To Hold Door At 90 Degrees P-2 Compartment	1
25-05-3000	< Superliner Curbside Rear Backboard Compartment SHOP NOTE: Includes Fixed .188" Vertical Divider Only. Install The Vertical Divider 11" From Wall #3. 17" Wide Pass-Thru X 20 7/8" Deep Compartment ILOS. Make Sure Compartment Is Deep Enough To Hold A Stryker Model #6252 Stair Chair. P-4 Compartment Includes Small Utility Compartment Behind The Wheel Well Area If Space Allows.	1
25-05-3500	< Superliner Full Height Streetside Front Compartment SHOP NOTE: 19 1/2" Wide X 20 7/8" Deep Compartment ILOS. D-1 Compartment	1
25-05-5000	< Superliner Streetside Double Door Intermediate Compartment SHOP NOTE: D-2 Compartment	1
25-05-8000	< Superliner Double Door Streetside Rear Compartment SHOP NOTE: D-3 Compartment To Be 6" Higher Than The D-2 Compartment Modify Height Of Interior Base Cabinet	1
25-11-8010	< Smooth Aluminum Adjustable Shelf W/ Ribbed Rubber Matting (Ea) SHOP NOTE: Smooth Aluminum With Standard 2" Lips. Specify Compartment: (1) D-1 Compartment Forward Of Vertical Divider. The Shelf Shall Be Installed To Allow A LSP Pediatric Immobilization Board Kit To Be Installed Under The shelf. Shelf Shall be Installed 48 1/2" From Top Of Dri-Deck To Bottom Of Shelf. Vertical Dividers Shall Be Adjusted To	7

PART NO	DESCRIPTION	QTY
	Accommodate The Shelf (1) D-1 Compartment Above The Shelf. (1) D-2 Compartment (1) D-3 Compartment Back Corners Of Shelf To Be Modified For Angle Plates For SCBA Storage. (3) P-4 Compartment Right Side Of Divider. Install Above The Stryker Model #6252 StairChair Storage Area.	
25-12-1000	< Fixed .125" Vortex Covered Aluminum Vertical Divider (Ea) SHOP NOTE: Specify Compartment: Install In The D-1 Compartment Forward Of The Main Oxygen Bottle NOTE: Divider Will Be Installed Part Way Down From The Ceiling (not full height divider) See Adjustable Shelf Requirements.	1
25-12-1110	< S.V.I. Adjustable Ceiling Backboard Divider (Ea) SHOP NOTE: Specify Compartment: Install An Adjustable Divider In The Ceiling Of The Rear Backboard Compartment To Prevent The Backboards From Coming Out Of The Compartment When The Door Is Open. Divider To Be Full Width Of The Backboard Area Only. Hang Down From The Compartment Ceiling Approximately 16" To Cover The Last 2"-3" Of The Backboard. The Last 1" Shall Be Angled Towards The Exterior With 30 Degree Angle.	1
25-12-1200	< S.V.I. Adjustable Long Board Slots (Ea) SHOP NOTE: Includes 2" Seat Belt Style Strap Across The Front Of The Dividers. Includes 2 Vortex Covered Back Wall Cushions. Specify Location: P-4 Compartment	3
25-12-8000	< Add IS/OS Access To Exterior Compartment (Ea) SHOP NOTE: Specify Compartment: P-4 Compartment In The Upper Right section Above The Stair Chair	2
25-12-9000	< Black Dri-Deck On Compartment Floor (Each) SHOP NOTE: Specify Compartment: D-1, D-2, D-3, P-1, P-4	5
25-12-9500	< Black Dri-Deck On Compartment Shelf (Each) SHOP NOTE: Specify Shelf: Install Dri-Deck On All Shelves Total (7)	7
25-13-5500	< Additional 1" Compartment Equipment Strap (Ea) SHOP NOTE: 1" Strap With Metal Buckle Unless Otherwise Specified. Specify Compartment Location: 1" Nylon Strap With A Metal Buckle Sized To Hold the Stryker Model #6252 Stair Chair On Wall #3 P-4 Compartment.	1
25-CS-0500	< S.C.B.A. Bracket (Ea) SHOP NOTE: Specify Compartment:D-3 Specify S.C.B.A. Brand: TBD Specify Tank Pressure Rating:TBD Specify Tank Minute Duration: TBD	2

PART NO	DESCRIPTION	QTY
25-CS-0720	<p>< Vortex Angled Bracket for SCBA Tanks (ea)</p> <p>SHOP NOTE: Specify Compartment: D-3</p> <p>Mount .188 Thick Vortexed Angled Plates In Compartment In Corner For SCBA Storage Brackets. Plates To Allow Brackets To Be Nut/Bolted To Plates. Design With Bracket Bolting To Welded Angle Plate In Corner.</p>	2
REAR STEP AND BUMPER ASSEMBLY		1
30-01-0000	<p>< Rear Bumper With Angled Style End Caps (LOW)</p> <p>SHOP NOTE: Includes Standard Reinforced Corner Angle Supports. Center Section And End Caps To Be At The Same Height ILOS</p>	1
30-01-3000	<p>< Recessed Rear Kick Plate For Bumper Flip Up Section</p> <p>SHOP NOTE: Requires Lowered Bumper</p>	1
30-01-3500	<p>< Full Width Diamond Plate Rear Kick Plate</p> <p>SHOP NOTE: Seal Top Edge</p>	1
IMPACT RAILS, STONE SHIELDS AND RUNNING BOARD		1
35-01-0000	<p>< One Piece Body Side Panels With Lower Impact Rails</p> <p>SHOP NOTE: Includes Lower Impact Rails Only.</p>	1
35-01-3000	Diamond Plate Running Boards With Grip Strut	1
35-01-7100	<p>< Whelen 2G 4" Round L3 Intensity Grommet Mounted Running Board Lights (Pr)</p> <p>SHOP NOTE: Part# 20COCD CD Lights Are Mounted With 2GROMMET Grommets Includes Deutsch Connectors</p>	1
35-01-7520	Rear Mud Flaps With Stainless Steel Hem Weights	1
35-01-8500	Add Rubber Mud Flaps To The Front Running Boards	1
35-01-9000	Stainless Steel Compartment And Entry Door Sill Plates	1
35-02-0000	<p>< Drip Rail Over Door (Ea.)</p> <p>SHOP NOTE: Specify Compartment: D-2, D-3, P-1, P-2, P-4</p>	5
35-02-1000	<p>< 24" High Front Stone Guards</p> <p>SHOP NOTE: With Sealed Top Edge.</p>	1
ELECTRICAL SYSTEM		1
40-00-0550	<p>< Elite G3 Touch Screen Electrical System</p> <p>SHOP NOTE: Includes: (1) Front Switch Panel, (1) Rear Switch Panel.</p> <p>(2) Carling Switches (1) Center Strip Lights (1) Momentary Disable Switch For Curb Side Scene Lights. Standard Location Is The R.F.S. Cabinet.</p> <p>(1) Electric Oxygen with Regulator And Oxygen Display. Regulator Mounted On A Bracket Remote From The Oxygen Tank.</p>	1

PART NO	DESCRIPTION	QTY
	Includes High Pressure Hose From The Tank To The Regulator. (3) Power Point Studs - They Will Include A Full-time Hot, Battery On (Ignition Hot), & Ground. These Are Rated 20 AMPS Or Less. Dealer To Specify Location: (1) Back-Up Camera (ASA VCCS150) BLACK HOUSING (This Camera Will Always Be Displayed Thru The Elite Front Touch Screen Unless Otherwise Specified) Street side Dome Lights On Low With Entry Door. (On High Is Not An Option) If Center strip Lights Are Not Ordered Then The R.F.S. Switch Will Turn On Both Sets Of Dome Lights On High. Inverter Will Come On With Ignition If One Is Specified, Along With Button Provided On Switch Panel.	
40-01-0301	< Add Second Rear Touch Screen (Elite System) SHOP NOTE: Specify Mounting Location: Mount To A Flat Mount Under The Head End Of Bandage Cabinet.	1
40-01-2000	< Reverse Activated Alarm With Momentary Auto Reset Switch SHOP NOTE: ECCO #575 Alarm.	1
40-01-5000	< Super Auto Eject Shoreline - 20 Amp SHOP NOTE: Specify Location: Over The D-2 Exterior Compartment. REQUIRES INTERIOR ACCESS PANEL. Specify Inlet Cover Color: (Red/White/Yellow/Gray) SPECIAL NOTE ABOUT 115 VOLT CURRENT DRAW (AMPS) This Unit Has A 20 Amp Shoreline Inlet That At A Capacity Rating Of 125% Has A Maximum Amperage Load Of 16 Amps. This Unit As Ordered Has A Total 115 Volt Amp Draw Of ** Amps. This Leaves A Reserve Of ** Amps For Interior Outlets. This DOES NOT Include Any Customer/Dealer Installed Equipment.	1
40-01-6900	< **FACTORY USE ONLY** SHOP NOTE: Shoreline Inlet Adapter Plug Present.	1
40-01-7500	< Shoreline On Indicator Light (Exterior) SHOP NOTE: Mounted Above Or Near The Shoreline Inlet. (Red LED). Whelen "OS" Series Non-Flashing Is The Std. Light (1) To Show Power To The Breakers	1
40-02-3500	< Vanner 20-1050 CUL 1000W Inverter With Display Includes 55 Amp Battery Charger SHOP NOTE: Specify Remote Charger Display Location: Drivers Side Front Console Specify Remote Inverter Display Location: Up High On The Electrical Closet Door	1
40-03-0000	< Action Area 12 Volt Power Outlet SHOP NOTE: Full Time Hot Circuit.	1
40-03-2000	< R.F.S. Cabinet 12 Volt Power Outlet SHOP NOTE:	1

PART NO	DESCRIPTION	QTY
	Mounted In The Lower Section On Wall #1. Full Time Hot Circuit.	
40-03-5500	< Add 12 Volt Power Outlet (Ea) SHOP NOTE: Full Time Hot Circuit. Specify Location: (1) Mounted Upper RFS Wall #1 (1) Mounted In Cabinet "K" Wall #1 (1) Mounted Telemetry area Above Countertop (1) Lower Section RFS Above The Upper shelf Wall #1 (1) Cabinet Above The Pass-Thru At Ceiling Level Wall #1 (1) Cabinet Above Pass-Thru Bottom Cabinet Wall #1 (1) On RFS Wall Above The Lower Pass-Thru cabinet	7
40-03-6000	< Action Area 125 Volt Outlet SHOP NOTE: Mounted In The Upper Section Wall #1	1
40-03-7000	< R.F.S. Cabinet 125 Volt Outlet SHOP NOTE: Mounted In The Lower Section On Wall #1.	1
40-03-8500	< Add 125 Volt Outlet (Ea) SHOP NOTE: Specify Location: (1) Action Area Next To CPR Seat (1) Lower Section RFS Above The Upper Shelf On Wall #1 (1) Cabinet Above The Pass-Thru Cabinet At Ceiling Level Wall #1 (1) Cabinet Above The pass-Thru Cabinet Bottom Cabinet On Wall #1 (1) On Back wall Over squad Bench Cushion, Head End of Squad Bench (1) Above The Lower Pass-Thru Cabinet On Wall Next to The 12V Outlet	6
40-04-4000	Power Door Locks For Side Entry & Rear Entry Doors	1
40-04-4500	< Additional Power Door Lock (Ea) SHOP NOTE: Door Locks Are Wired Thru The O.E.M. Door Lock Switches. Door Locks Are Thermally Protected With Pulsed Signals. Specify Compartment Location: (1) D-1,(1) D-2, (1) D-3, (1) P-1, (1) P-4	5
40-04-5500	Hidden Switch In Grille For Power Door Locks (Unlock Only)	1
40-04-6000	Hidden Switch In Rear License Plate Housing (Unlock Only)	1
40-04-7000	< Interior Body Switch For Power Door Locks (Ea) SHOP NOTE: Specify Location: RFS Wall	1
40-05-0500	< 2 Kenwood Speakers Mounted In The Ceiling Center Strip SHOP NOTE: Volume Control Mounted In The Street Side Action Area. KFC-1365S Speakers.	1
40-05-1600	< 12 Volt Power And Ground Circuit For Flashlight (Ea) SHOP NOTE: Specify Location: D-3 Compartment, On Wall #1 Under Shelf (1) In Cab Area Rear of Passenger Seat For Future Location Of Hand lights. Leave a 4' Service Loop At Each Location. Full Time Hot	2

PART NO	DESCRIPTION	QTY
INTERIOR LIGHTING		
45-01-0000	Oxygen Compartment Light	1
45-01-0500	< Side Entry Door Stepwell 3" Round LED Light SHOP NOTE: Whelen 3" Round Super-LED Surface Mounted	1 1
45-01-2600	< Whelen #80C0EHZR "LED" Round Ceiling Light ILOS (Ea) SHOP NOTE: CLEAR LENS 4- Street Side 4- Curbside	8
#80C0EHCR IS THE PART NUMBER FOR A FROSTED LENS LIGHT		
45-01-3000	12" Grote 60591 LED Action Area Light	1
45-01-7540	< 4-ROM 18" Rectangular DuroLumen Recessed "LED" Center Strip Lights SHOP NOTE: Includes Switch In Switch Panels For Lights To Operate On 12V With HI/Lo Switch. Part #R03853 Lights Will Be On Hi With Timer Switch. Specify Switch Location: RFS WALL	1 1
EXTERIOR LIGHTING		
50-01-0000	< Whelen 600 Series "LED" Stop/Tail Lights (Pr) SHOP NOTE: Use Whelen #60BTT Lights (Meets SAE Requirements). Mounted Above The Rear Kick Plate.	1 1
50-01-6000	< Whelen 600 Series "LED" Populated Amber Turn Lights (Pr) SHOP NOTE: Mounted Above The Rear 600 Series LED Stop/Tail Lights. Wire To Flash Sequentially In The Direction Of The Arrow.	1
50-02-6000	< Whelen 600 Series "LED" Populated Amber Turn Light IATS (Pr) SHOP NOTE: Specify Location: Front Of Module Mount Under The (2) Upper / Outer 900 Series Red LED Lights Wire To Flash Sequentially In The Direction Of The Arrow	1
50-02-9000	< C.P.I. License Plate Housing SHOP NOTE: Mount In The Recessed Area In The Rear Kickplate	1
50-02-9510	< Whelen 600 Series "LED" Populated Back-Up Lights (Pr) SHOP NOTE: Mounted Above The Rear Turn Lights Unless Otherwise Specified. Model #60C00WCR Maximum Intensity	1
50-03-2100	< Two Reverse Activated Whelen 900 "LED" Rear Load Lights SHOP NOTE: 24 Diode #9SC0ENZR Lights.	1
50-03-5600	< Whelen 900 "LED" Side Scene Lights (Two Each Side) SHOP NOTE: 24 Diode #9SC0ENZR Lights.	1

PART NO	DESCRIPTION	QTY
50-03-9000	Right Side Scene Lights On With Open Side Entry Door	1
50-04-2000	Rear Side Scene Lights On In Reverse IATS	1
50-04-5000	< Wire Rear Emergency Light Flashers To Brake Circuit IATS	1
	SHOP NOTE: Specify Light Location: (2) Rear Upper / Outer 900 Series Red LED Lights	
50-04-5700	< Recessed Truck-Lite 60 "LED" Door Light (Red or Amber)(Ea)	4
	SHOP NOTE: Specify Location And Color: (2) Lower Outer Corners Curbside Door (1) Top, (1) Bottom (2) One (1) Each Rear Lower / Outer Corner Of Each Rear Door ALL LIGHTS RED. E23019 60052R "60" LED Trucklite Red with Chrome Trim	
50-04-7501	< Whelen "OS" Series LED ICC Marker Lights ILOS (Ea)	6
	SHOP NOTE: Part #OSOOMCR (AMBER) Part #OSROOMCR (RED)	
50-04-8000	< Innovative Lighting Slimline Rear DOT/Brake Light	1
	SHOP NOTE: Mounted Above The Rear Doors. Mounted Above The Drip Rail Unless Otherwise Specified. Mid Sections To Be Wired Thru The Brake Light Circuit.	
50-04-8100	< Innovative Lighting Slimline Front DOT Light	1
	SHOP NOTE: Mounted Above The Drip Rail Unless Otherwise Specified.	
	< ***RADIO PROVISIONS AND AIR HORNS*** SHOP NOTE: Pricing does not include installation of customer supplied radio equipment unless otherwise stated. All customer supplied radio equipment must be received at Life Line prior to construction start date.	1
55-01-8400	< Three Power Point Studs Located In The Interior Electrical Compartment	1
	SHOP NOTE: The studs shall include a full-time hot, ignition hot, and ground.	
55-01-8500	< KE-794 Antenna Base With Coax	1
	SHOP NOTE: Specify Termination Location: (1) Front Module Roof To The Driver's Seat Base. (Unless Otherwise Specified). Leave A 36" Service Loop	
55-02-1500	< KE-794 Module Roof Antenna Base/Coax (Ea)	3
	SHOP NOTE: Specify Termination Location: (1) Mid Modular Roof To Drivers Seat Base (1) Mid Module Roof To Drivers Seat Base (1) Rear Modular Roof To The street Side Action Area, Coiled Up Behind The Switch Panel. Note Leave A 36" Service Loop At Each location Roof Antenna's Must Be Minimum 18" Apart INSTALL RAINCAPS AT EACH LOCATION	
55-02-5500	< Radio Pre-Wire Power And Ground 20 AMP Or Less Circuit (Ea)	3
	SHOP NOTE:	

PART NO	DESCRIPTION	QTY
	Full Time Power And Ground And Battery On (Ignition On) Circuits. Butt Splice Termination Points. Specify Termination Location: (1) 20 Amp Covered Buss Bar Behind The Drivers Seat Install Inboard Towards The Seat Belt Side Full Time Hot / Ground And Ignition On Circuit (1) 20 Amp Covered Buss Bar Behind The Street Side Rear Switch Panel Full Time Hot / Ground And Ignition On Circuits (1) 20 Amp Covered Buss Bar Under The Front Console Full Time Hot / Ground And Ignition On Circuits	
	SIRENS AND EMERGENCY LIGHTING	1
60-01-3500	< Whelen 295HFSC9 Dual Amp Siren SHOP NOTE: Specify Custom Siren: Whelen #295HFSC9 Dual Amp Siren	1
60-01-4000	Federal ESB-12FEVN Behind Grille Siren Speakers (E-Series)	1
60-01-9000	< 4 Whelen 900 Super "LED" Side Module Warning Lights SHOP NOTE: Part #90RR5FRR Red Lens Mount The Side Lights Inline. Comet Flash Pattern Wire Primary / Secondary Circuit	1
60-02-5000	< Delete The 2 Standard Front Module Warning Lights (Credit) SHOP NOTE: Deleted Due To The (7) 900 LED Lights On Front Of Module	1
60-02-8100	< Delete The Standard Center Front Module Warning Light (Credit) SHOP NOTE: Deleted Due to The (7) 900 Series LED Lights On Front Of Module	1
60-02-9500	< 2 Whelen 900 Super "LED" Rear Module Warning Lights SHOP NOTE: #90RR5FRR With Red Lens Unless Otherwise Specified.Comet Flash Pattern: Wire Primary / Secondary Circuit	1
60-04-4500	< Delete The Standard Rear Center Warning Light (Credit) SHOP NOTE: Deleted To Install A Whelen Model 600 Series AMBER LED Light With the Back Up Camera	1
60-04-4610	< Emergency Lights On In Reverse SHOP NOTE: Specify which Button on the touch screen or flasher circuit is to be activated. "REAR FLASHER" Circuit	1
60-04-5300	< 2 Whelen 500 Super "LED" Grille Lights SHOP NOTE: #50R02ZRR Red Lens Comet Flash Pattern Wire Primary / Secondary Circuit	1

PART NO	DESCRIPTION	QTY
60-05-0500	< 2 Whelen 700 Super "LED" Intersection Lights SHOP NOTE: Part#70R02FRR Red Lens Model #70R02FRR Comet Flash Pattern Wire Primary / Secondary Circuit	1
60-06-0650	< Wig Wag Headlights SHOP NOTE: Add Wig Wag Headlights With Whelen #SSFPOS Flasher. Disables OEM DRL headlights.	1
60-06-6000	< 2 Whelen 700 Super "LED" Rear Wheel Well Lights SHOP NOTE: Specify Whelen Light Number:#70R02SRR Red Lens Comet Flash Pattern Wire Primary / Secondary Circuit	1
60-07-1520	< 7 Whelen 900 Super "LED" Front Module Warning Lights Color Lens SHOP NOTE: Specify Whelen Part #: (1) #90WW5SWR WHITE Lens (6) #90RR5SRR RED Lens Comet Flash Pattern Wire Primary / Secondary Circuit NOTE: THE NON-KKK LIGHTS TO FLASH UP / DOWN.	1
60-08-2000	< Pre Wire For Opticom With Park Disable Feature SHOP NOTE: Includes Park Disable Circuit. Specify Pre Wire Termination Location: Behind The Center White LED Light On Front Of Modular	1
60-09-4452	< Whelen 500 Clear Super "LED" Light (Ea) SHOP NOTE: Specify Location: Lower Grill Bar Specify Whelen Light Number:#50C02ZCR Specify Comet Flash Pattern Wire Primary Circuit Note; These And The Upper Grille Red LED Lights To Flash In A "X Pattern..	2
60-09-7000	< Whelen 600 Red Or Amber Or Blue Super "LED" Light (Ea) SHOP NOTE: Specify Location:Centered Over The Rear Doors Mounted Above the Camera Specify Whelen Light Number: #60A02SAR Amber Lens Specify Comet Flash Pattern Wire Primary / Secondary Circuit	1
60-10-0130	< Rear Window Level Whelen 900 Red Or Amber Or Blue Or Clear Super "LED" Lights(2) SHOP NOTE: Specify Whelen Light Number: #90RR5SRR Red Lens Specify Comet Flash Pattern Wire To Separate Switch In Front Console Labeled "Rear Flashers"	1

PART NO	DESCRIPTION	QTY
60-10-2000	<p>< Whelen 900 Red/Amber/Blue or Clear Super "LED" Light (Ea)</p> <p>SHOP NOTE: Specify Location: (2) Whelen 900 Series LED Lights Mounted Next To The (2) Over Rear Door Scene Lights Specify Whelen Light Number: #90RR5SRR Red Lens Specify Comet Flash Pattern</p> <p>These To Flash In A "X" Pattern In Conjunction With The (2) 900 Serles Red LED Lights Mounted At The Rear Door Window Level.</p>	2
60-11-5000	<p>< Whelen AFM560 LED/Halogen Flasher 5-Outlet 60 Watts (Ea)</p> <p>SHOP NOTE: Flasher #1 To Flash The Following; (7) Front Wall 900 Series LED Lights. Split Up Heads To Get Highest Intensity (4) 500Series Grille lights These To Flash In A "X" Pattern (2) Front Fender 700 Series LED Lights (2) Rear Wheel well 700 Series Intersection Lights (2) 900 Series LED Lights Mounted Over The Rear Doors Next To The Rear Upper Scene Lights (2) Rear Window 900 Series LED Lights (4) Side 900 Series LED Lights (1) Whelen Model 600 Amber LED Light Mounted Over Th Rear Doors (KKK Light)</p> <p>Install Scan Lock Buttons At Each Location</p> <p>NOTE: If A Second Flasher is Needed Please Add It.</p>	1
<p>***PATIENT COMPARTMENT***</p>		1
65-00-9900	<p>< SPECIAL NOTE TO DEALER</p> <p>SHOP NOTE: Custom Cabinet Options/Designs Not Listed In The Published Options List MAY Result In Additional Charges.</p>	1
65-01-2000	<p>Standard Smooth Headliner</p>	1
65-01-3000	<p>< 1/4" Clear Polycarbonate Sliding Doors On Cabinets</p> <p>SHOP NOTE: Includes Brushed Finish Interior Trim.</p>	1
65-02-2010	<p>Delete All Cot Mounts For Power Load Set-Up</p>	1
65-02-2252	<p>< Stryker 6392 Performance Load System With Inductive Charger & Floor Plate</p> <p>SHOP NOTE:</p> <p>The following Cot Models Work With this Option: Power-Pro XT & Power-pro IT Includes Floor Mount Only For Push rail And Stand. This Option Includes The Credit For Deleting The Standard Cot Mounts And Push Rail. COT NOT INCLUDED.</p>	1
65-02-2310	<p>Short Push Rail and Stand Up Mount</p>	1
65-02-8000	<p>< L.R.O. Cabinet With Speed Load Door</p> <p>SHOP NOTE: With Positive Lock Feature. To include [1] PVC shelf</p>	1

PART NO	DESCRIPTION	QTY
65-03-3500	< Cabinet Above The Side Seat With Speed Load Door SHOP NOTE: To be 8.25"H With Positive Lock Feature.	1
65-03-7500	< L.F.O. Cabinet With Speed Load Door SHOP NOTE: With Positive Lock Feature. To include [1] PVC shelf.	1
65-04-1000	< Left Rear Base Cabinet With Sliding Polycarbonate Door SHOP NOTE: Includes (2) Adjustable shelves	1
65-04-6600	< Delete Standard Telemetry Area Cabinet SHOP NOTE: Telemetry Area To Be 6-8" Wide Wide Enough For retaining Lips On Countertop And Drop In Sharps container MATCH UNIT #299610SD	1
65-04-7000	Lower Telemetry Area Cabinet With Sliding Polycarbonate Door	1
65-04-8500	< Action Area Cabinet With Sliding Polycarbonate Door SHOP NOTE: Move The switch Panel Towards The Side CPR Seat As Much As Possible. Allow 11" Between The Switch Panel And the Action Area Cabinet to Allow For 2 Way radios To Be Installed / Recessed Into Face Of Cabinet. SAME AS #299610SD Mount The Volume Control Knob Towards The Front Of The Module Below The Action Area Cabinet In The Upper Right Hand Corner.	1
65-05-0000	< Slanted Action Area Switch Panel SHOP NOTE: Includes Sliding Polycarbonate Doors Forward Of The Switch Panel Unless Otherwise Specified.	1
65-05-2100	< Delete Standard Lower Action Area Cabinet (Factory Use) SHOP NOTE: Deleted Due To Custom Compartment Or Cabinet Design ILOS.	1
65-05-3000	< Action Area Tip-Out Trash Cabinet With Wide Ext Comp Option SHOP NOTE: Notch Exterior Compartment To Allow For Interior Cabinet. 10" High Bottom Hinged Wood Access Door. Size Bracket For #8970 Sharps Or Trash Container Rubbermaid Move As Close To CPR Seat As Possible	1
65-05-4500	< Side Facing CPR Seat With Rear Hinged Lid For Storage SHOP NOTE: Includes Lap Seat Belt. Includes 29" Of Seating Area Hip Pads Are Full Depth	1
65-05-8500	< EVS 1880S Child Rear Facing Seat On Pedestal/Swivel Base SHOP NOTE: Specify Medi-VAC Color: TBD #1880S Seamless EVS Seat. Requires EVS Provided Pedestal Base For Compliance. Includes 3-Point Seat Belt. Question: Will there be an O2 Bottle Attached to the Head of the Cot? Requires Lower Streetside Aisle Cabinet And Bulkhead Wall Cabinet For Overflow Electrical Equipment.	1

PART NO	DESCRIPTION	QTY
65-06-2500	Rear Facing Electrical Cabinet And Door With Lock	1
65-06-9000	< Cabinet Above The Walk-Thru With Hinged Solid Door SHOP NOTE: Specify Hinge Side: (2) Top Hinged Cabinets Of Equal Size With Solid Wood Doors See Drawings For Dimensions.	2
65-06-9500	< Right Front Upper ALS Cabinet With Solid Doors SHOP NOTE: Above The Lower IS /OS Access Use Straps On Doors ILO Chains Cabinet To Be 10" Clear Opening Height Includes (1) Adjustable Shelf In Each Cabinet	1
65-07-3000	< Right Front Lower ALS Cabinet With Solid/Polycarbonate Doors SHOP NOTE: Solid Surface Door With Vented Poly carbonate Inserts. To Have Flush Bottom Section ILOS Use Straps On Doors ILO Chains	1
65-07-9000	< Add Cabinet In The Lower Walk-Thru Area SHOP NOTE: With Solid Surface Counter Top Area. Includes (1) Adjustable Shelf Wood Doors With Poly Carbonate Inserts Make Cabinet As Deep As Possible	1
65-08-0000	< Curbside Squad Bench With 2 Piece Lid And No Divider SHOP NOTE: Includes 3 Sets Of Lap Seat Belts. Includes 3 Cot Restraints.	1
65-08-2000	Delete Squad Bench Post/Wheel Cups	1
65-08-5000	< Formed Stainless Removable Sharps And Waste "A" Bar SHOP NOTE: Mounted At The Head Of The Squad Bench ILOS Cushion Area. NOTE SHARPS CONTAINER ONLY-USE METAL BAND ILOS. DELETES STANDARD HEAD PAD #65-08-35. DELETES STANDARD ASSIST RAIL #65-10-20.	1
65-08-8500	Squad Bench Backrest Cushion	1
65-09-2000	< Two Section Bandage Cabinet With Speed Load Doors SHOP NOTE: With Positive Lock Feature. Specify Cabinet Depth: 8.50" Deep X 8.25" High Foward End Is Stepped Back For O2 Outlet. See Overhead Drawiung	1
65-09-6000	< Recessed Glove Box Storage In Cushion Area Above Doors(Ea) SHOP NOTE: Recessed Storage Box With Top Hinged Polycarbonate Door. Specify Location: OVER REAR DOORS Specify Number Of Box Cut-Outs: (1) EACH, TOTAL (2) SPECIAL NOTE: Unless Otherwise Specified, Cabinet Will Fit A 5" High x 10" Wide x 4" Deep Glove Box.	2

PART NO	DESCRIPTION	QTY
65-09-6100	< Recessed Glove (Three) Box Storage In Side Door Cushion Area SHOP NOTE: Recessed Storage Box With Top Hinged Polycarbonate Door. SPECIAL NOTE: Unless Otherwise Specified, Cabinet Will Fit A 5" High x 10" Wide x 4" Deep Glove Box.	1
65-09-8500	100" Long Formed Streetside Ceiling Grab Rail	1
65-09-9500	100" Long Formed Curbside Ceiling Grab Rail	1
65-10-0500	Formed "L" Door Assist Rails Mounted On The Hinge Side	1
65-10-2000	Formed Assist Rail At The Head End Of The Squad Bench	1
65-10-3000	Delete Formed Assist Rail On The Left Rear Wall	1
65-10-5000	< Two C.P.I. #IV2008 Rubber Recessed IV Brackets SHOP NOTE: Mounted In The Mid/Rear Cot Position.	1
65-10-6100	< Add C.P.I. #IV2008 Rubber Recessed IV Bracket (Ea) SHOP NOTE: Specify Location: Forward Cot Position	2
65-10-9000	Southco M1 Stainless Cabinet Latches	1
65-12-2810	< BRG LED Digital Clock Mounted In Rear Head Cushion SHOP NOTE: Part# E26092	1
65-12-3600	< Locking Cabinet Door (Separate Cylinder Lock) SHOP NOTE: Specify Cabinet Location: (1) Cabinet Above Pass-Thru Ceiling Level (1) Cabinet Above Pass-Thru Lower Cabinet (1) Upper RFS Drug Cabinet (Solid wood Door)	3
65-12-4700	< Southco M1 Stainless Double Locking Cabinet Door SHOP NOTE: Specify Cabinet Location: Includes Double Door Cabinet Option. Both Doors Over The Pass-Thru Cabinets	2
65-12-5200	< Simplex 900 Series Lock (Ea) SHOP NOTE: Specify Location: (1) Upper RFS Cabinet / Interior Access Only	1
65-12-8500	< Drop In Sharps In The Telemetry Area SHOP NOTE: In The Telemetry Area #85131 Sharps Container	1
65-12-9700	< Tip Out Trash Container SHOP NOTE: Specify Location: Head Of Squad Bench On The Aisle Side To Fit Waste Or #8970 Sharps Container Match Street side Wall 10" High Door With Metal Band ILOS Line The Face Of Door With Brushed Stainless Steel ILO Formica	1
65-13-4080	< Ferno Washington LifePak Monitor Bracket SHOP NOTE: Specify Model #: FERNO M-200 Specify Mounting Location And Include Overall Dimensions of Monitor With Bags:	1

PART NO	DESCRIPTION	QTY
	(1) FERNO MODEL M-200 SWIVEL BRACKET FOR A L.P. MODEL 15 WITH BAGS AT EACH END. MOUNTING LOCATION TBD.	
65-13-5500	< Additional Interior Adjustable Shelf (Ea) SHOP NOTE: Specify Cabinet Location: (2) One In Each Pass-Thru Cabinet (1) In The RFS Upper Cabinet (under The Heat/ AC)	3
65-14-4500	< Adjustable Vertical Shelf Divider (Ea) SHOP NOTE: Specify Cabinet Location: (3) Floor Of The Front Section Of The LFO Cabinet (3) Shelf Of The Front section Of the LFO Cabinet (3) Floor Of the Rear Section Of The LFO Cabinet (3) Shelf Of the Rear Section Of The LFO Cabinet (3) Bandage Cabinet Forward Section (3) Bandage Cabinet Rear section	18
65-CS-1020	< Add Flat Cabinet For The 2nd Rear Switch Panel SHOP NOTE: Mounted At The Head End Of The Squad Bench Below The Bandage Cabinet. (Requires 8" Deep Bandage Cabinet).	1
65-DL-0100	< Fire Extinguisher Cabinet SHOP NOTE: Specify Custom Option: Add street side Aisle side Fire Extinguisher Cabinet Forward Hinged H. D. Framed Plexiglas Door Make Cabinet As High As Possible	1
65-DL-0200	< Cabinet Unistrut Tracking ILOS SHOP NOTE: Specify Custom Option: Install Unistrut Shelf tracks For All Cabinet shelves	1
	PATIENT COMPARTMENT ENVIRONMENTAL SYSTEMS	1
70-01-0500	< 12 Volt Powered Fresh Air Intake SHOP NOTE: Circuit Wired Thru The Exhaust Vent Circuit And Switch.	1
70-01-1000	12 Volt Powered Exhaust Fan	1
70-01-1500	< 12 Volt Pro Air Thermostat Controlled Rear Heat/AC Unit SHOP NOTE: Includes Digital Temperature Display. Includes Climate Indicators For Heat/AC/Fan Speed. Includes High-Medium-Low Fan Speeds. DO NOT WIRE THROUGH EMERGENCY MASTER SWITCH.	1
70-01-2400	< Inline Booster Coolant Pump SHOP NOTE: 12 Volt Centrifugal Pump To Boost The Flow Capacity Of The Coolant System.	1

PART NO	DESCRIPTION	QTY
70-01-2500	Standard R.F.S. Overhead Cabinet Heat/AC Unit Location	1
70-01-6000	< Yellow Certifoam High Density Insulation Body/Floor/Doors (R-6) SHOP NOTE: GAS CHASSIS' INCLUDE THERMOTECH HEAT BARRIER PART #F18084. THIS GOES ON THE HEAT SHIELD THAT GOES OVER THE AXLE. THIS ALSO GETS THE THERMO HEAT INSULATION BLANKET ON THE BOTTOM OF THE FLOOR AND GOES FROM THE FRONT OF THE MODULE TO THE FUEL TANK.	1
70-01-6600	Automotive Grade Undercoating Under Module Body ***OXYGEN SYSTEM***	1 1
75-01-0000	< Ohio Style Action Area Oxygen Outlet SHOP NOTE: See Action Area Drawing For Exact Location	1
75-01-2000	Ohio Style Ceiling Mounted Oxygen Outlet	1
75-01-4000	< Ohio Style Right Wall Mounted Oxygen Outlet SHOP NOTE: Mounted On The Head Of The Bandage Cabinet In The Stepped Back Area. Allow For Ball Type Flow Meter And Fitting On Bottom With Tubing To Be Easily Installed. Design To Allow The Flow meter To Be Near Flush With The face Of Cabinet When Installed In The Ohio Outlet. See Overhead drawing Of cabinet.	1
75-01-6500	< Add Ohio Style Oxygen Outlet(s) (Ea) SHOP NOTE: Specify Location: (1) Action Area Next To Standard	1
75-01-8000	< Interior Oxygen Access/Viewing Door SHOP NOTE: ACCESS DOOR WILL BE POLYCARBONATE FRAMED DOOR UNLESS OTHERWISE SPECIFIED.	1
75-02-0000	< "M" Oxygen Tank Bracket In Non-Standard Location SHOP NOTE: Specify Location: D-1 Compartment Wall #2 Right Side	1
75-02-3710	< Drill Mounting Plate For Both "H" or "M" Tank For O2 Bracket SHOP NOTE: Order with Ratchet Style Straps #3030-135-138	1
75-02-9500	Oxygen Wrench Installed In Oxygen Compartment/Cabinet	1
75-03-3010	< ZICO Model QR-D-2 Quick Release Strapless Portable Oxygen Tank Bracket SHOP NOTE: Specify Location: Mount In Curbside Step well Area DO NOT DROP the Step well Raise Up Off The Floor For Cleaning 2-3"	2
	SUCTION SYSTEM	1
80-01-0000	12 Volt Gast Suction Pump With Action Area Switch	1
80-01-1500	< 1 Ohio Style Action Area Suction Outlet SHOP NOTE: Provided For Disconnect For SSCOR Suction	1
80-01-7500	< SSCOR 22000 Suction Unit W/23002 Disposable Trap Set SHOP NOTE:	1

PART NO	DESCRIPTION	QTY
	Includes Flush Mounted Action Area Panel And Disposable Trap Set.	
	PAINT	1
85-00-0100	< Standard Axalta Paint Process And Warranty SHOP NOTE: Includes 6 Year Pro-Rated DuPont Paint Warranty.	1
85-01-0000	< Repaint Chassis ILOS O.E.M. White SHOP NOTE: Specify Color: RED #N0235 Touch-Up Paint Is Included For Colored Chassis.	1
85-01-1500	< Paint Module Body Other Color ILOS O.E.M. White SHOP NOTE: Specify Color: RED #N0235 Touch-Up Paint Is Included For Colored Module Body. Send (2) Spray Out Cards For Customer Approval	1
85-01-4500	Delete Standard Beltline Stripe	1
85-02-8500	< Custom Two-Tone Paint SHOP NOTE: Specify Location And Color: Paint Modular Roof OEM WHITE From The "T" Tops In. Paint So The White Cannot Be Seen From The Ground	1
85-02-9500	Do Not Paint The Nader Pins/Install After Paint Process	1
85-03-2500	Delete Standard Edge Pinstripe	1
85-03-3500	< 1" Scotchlite Striping (Per Foot) SHOP NOTE: Specify Color And Location: (2) 1" 3M Reflective Stripes NOTE: This Striping Will Be A 1-8-1" Stripe Design * 1" 3M White Reflective Stripe * Leave 1" Red Paint showing * 8" 3M White Reflective Stripe * Leave 1" Red Paint Showing * 1" 3M White Reflective Stripe NOTE: SEE ATTACHED PHOTO'S OF STRIPE LAYOUT. NOTE: THE 1/2" GOLD STRIPE WILL BE INSTALLED AT SVI NOTE All Striping Will Be On Each Side And The Rear	1
85-03-5500	< 8" Scotchlite Striping (Per Foot) SHOP NOTE: Specify Color And Location: *1" WHITE 3M Reflective Scotchlite Stripe * Leave 1" Red Paint Showing * 8" WHITE 3M Reflective Scotchlite Stripe * Leave 1" Red Paint Showing * 1" WHITE 3M Scotchlite Stripe NOTE: SEE ATTACHED PICTURES OF STRIP LAYOUT NOTE; The 1/2" Gold Stripe Will Be Installed At SVI	1

PART NO	DESCRIPTION	QTY
	EMBLEMS AND DECALS	1
90-01-0000	< Federal Star Of Life/Ambulance Decal Package SHOP NOTE: Install Roof Star Of Life Decal. Ship Remainder Of Decals Loose. (2) 4" Star Of Life Decals. (2) 12" Star Of Life Decals. (2) 18" Star Of Life Decals. (3) 6" AMBULANCE Decals. (1) 4" Reverse AMBULANCE Decal.	1
90-01-1100	< "NO SMOKING" - "FASTEN SEAT BELT" Decals SHOP NOTE: 1-Installed In The Cab. 1-Installed In The Module.	1
90-01-1200	No Other Decals or Lettering Included Unless Specified Below	1
90-01-5100	< Install 3/4" White Reflective Tape Around Side And Rear Entry Doors SHOP NOTE: KKK-F Certification Requirement.	1
	DEALER SUPPLIED AND INSTALLED OPTIONS	1
	< SHOP NOTE: THIS SECTION IS FOR DEALER SUPPLIED AND INSTALLED OPTIONS AFTER DELIVERY FROM LIFE LINE.	
95-DL-0100	< OUR QUOTE INCLUDES SHOP NOTE: Our Quote Includes; *Delivery To Jamestown Fire Department * All Lettering / Striping To Match Present Fleet *Plymovent Ring On The Tail Pipe	1
	END OF QUOTE/PRODUCTION ORDER	1
95-SP-0100	< 1 Original & 1 Revision Work Order Before Penalty Pricing SHOP NOTE: 1 Original Draft & 1 Revision Draft Work Order Before Penalty Pricing. The Revision Rate Is \$120.00 Per Hour With 1 Hour Minimum Charge.	1
95-SP-0200	< 1 Original & 1 Revision Drawing Before Penalty Pricing SHOP NOTE: 1 Original Draft & 1 Revision Draft Drawing Before Penalty Pricing. The Revision Rate Is \$120.00 Per Hour With 1 Hour Minimum Charge.	1
95-SP-0600	Change After Sign-Off (Published Price + 50%)	1
95-SP-0700	Change After Production Start (Published Price + 75%)	1
95-SP-0800	Change After Production Completion (Published Price + 100%)	1
	SIGNATURE-LIFE LINE EMERGENCY VEHICLES	1
	< SHOP NOTE: This Is A Contract Between Life Line Emergency Vehicles And The Franchised Distributor Entering The Order. No Agreements Verbal Or Written Arrived At Between The Selling Distributor And The Purchasing Agency Not Listed On This Order Are Binding Upon Life Line Emergency Vehicles. THE VEHICLE IS BUILT TO THIS PRODUCTION ORDER. IT IS THE DISTRIBUTORS RESPONSIBILITY TO ASSURE THE VEHICLE MEETS THE CUSTOMER SPECIFICATIONS. Date Of Order: SPECIFY	

PART NO	DESCRIPTION	QTY
	Franchised Distributor: SPECIFY	
	Quote Number: SPECIFY	
	Ordered By: _____	

**TOWN COUNCIL SPECIAL MEETING
October 3, 2016**

I. ROLL CALL

Town Council Members present:

Kristine S. Trocki, President
Mary E. Meagher, Vice President
Blake A. Dickinson
Michael G. White
Thomas P. Tighe

Also in attendance:

Andrew E. Nota, Town Administrator
Christina D. Collins, Finance Director
Michael C. Gray, Public Works Director
Peter D. Ruggiero, Town Solicitor
Wyatt A. Brochu, Town Solicitor
Cheryl A. Fernstrom, Town Clerk

II. CALL TO ORDER

Council President Trocki called the special meeting of the Jamestown Town Council to order at 5:37 p.m. in the Jamestown Town Hall Conference Room at 93 Narragansett Avenue.

III. NEW BUSINESS/EXECUTIVE SESSION

The Town Council may seek to go into Executive Session to discuss the following items:

- A) Pursuant to RIGL §42-46-5(a) Subsection (1) Personnel (Town Administrator's Performance Review); review and discussion and/or potential action and/or vote in executive session and/or open session

A motion was made by Vice President Meagher with second by Councilor White to enter into Executive Session at 5:35 p.m. pursuant to RIGL §42-46-5(a) Subsection (1) Personnel.

Pursuant to RIGL §42-46-5(a) Subsection (1) Personnel, the following vote was taken: President Trocki, Aye; Vice President Meagher, Aye; Councilor Dickinson, Aye; Councilor White, Aye; Councilor Tighe, Aye.

The Town Council reconvened the special meeting at 6:19 p.m. President Trocki announced that no votes were taken in Executive Session.

A motion was made by Councilor White with second by Vice President Meagher to

seal the Minutes of Executive Session. President Trocki, Aye; Vice President Meagher, Aye; Councilor Dickinson, Aye; Councilor White, Aye; Councilor Tighe, Aye.

IV. ADJOURNMENT

A motion was made by Councilor White with second by Vice President Meagher to adjourn. President Trocki, Aye; Vice President Meagher, Aye; Councilor Dickinson, Aye; Councilor White, Aye; Councilor Tighe, Aye.

The special meeting was adjourned at 6:20 p.m.

Attest:

Cheryl A. Fernstrom, CMC, Town Clerk

Copies to: Town Council
 Town Administrator
 Finance Director
 Solicitor

**TOWN COUNCIL MEETING
October 3, 2016**

I. ROLL CALL

Town Council Members present:

Kristine S. Trocki, President
Mary E. Meagher, Vice President
Blake A. Dickinson
Michael G. White
Thomas P. Tighe

Also in attendance:

Andrew E. Nota, Town Administrator
Christina D. Collins, Finance Director
Lisa W. Bryer, Town Planner
Michael C. Gray, Public Works Director
Edward A. Mello, Police Chief
Fred Pease, Town Sergeant
Cathy Kaiser, School Committee Chair
Wyatt A. Brochu, Town Solicitor
Cheryl A. Fernstrom, Town Clerk

II. CALL TO ORDER, PLEDGE OF ALLEGIANCE

Council President Trocki called the regular meeting of the Jamestown Town Council to order at 7:07 p.m. in the Jamestown Town Hall Rosamond A. Tefft Council Chambers at 93 Narragansett Avenue, and Councilor Dickinson led the Pledge of Allegiance.

**III. ACKNOWLEDGEMENTS, ANNOUNCEMENTS, RESOLUTIONS
AND PROCLAMATIONS**

None.

A motion was made by Vice President Meagher with second by Councilor White to move up agenda items IX. Ordinances and Appointments A) Appointments and Vacancies and VI. Reports A) Administrator's Report: Town Administrator Andrew E. Nota to the next items to be addressed. President Trocki, Aye; Vice President Meagher, Aye; Councilor Dickinson, Aye; Councilor White, Aye; Councilor Tighe, Aye.

IX. ORDINANCES AND APPOINTMENTS AND VACANCIES

- A) Appointments and Vacancies
 - 1) Jamestown Housing Authority (One vacancy with an unexpired five-year term ending date of December 31, 2017); duly

- advertised; no applicants
- 2) Jamestown Tax Assessment Board of Review – Alternate (One vacancy with a one-year term ending date of May 31, 2017); duly advertised; no applicants
- 3) Jamestown Tree Preservation and Protection Committee (One vacancy with an unexpired three-year term ending date of December 31, 2016); duly advertised; no applicants

President Trocki noted the three vacancies and encouraged citizens to apply.

VI. COUNCIL, ADMINISTRATOR, SOLICITOR, COMMISSION/COMMITTEE COMMENTS & REPORTS

A) Administrator’s Report: Town Administrator Andrew E. Nota

1) 2016 ICMA Conference

Town Administrator Nota reported on the 102nd ICMA Conference he attended in Kansas City, MO last week, with speakers and sessions pertaining to many issues facing Jamestown and communities across the country.

2) Local incident – Fire Station

Mr. Nota reported on a bomb threat that occurred last Sunday at approximately 7:30 p.m. He thanked the family who encountered the threat, the Jamestown Fire Department, and the Jamestown Police Department for their appropriate actions. A full investigation took place and is ongoing, and was handled very professionally by our public safety departments. Fortunately, the incident turned out to be a hoax. President Trocki noted such matters must be taken seriously, and our Police Department and Fire Department should be commended for their professional handling of the situation.

3) Professional Development

Mr. Nota reported on senior staff members who attended the RI Interlocal Risk Management Trust seminar on Disruption Readiness that outlined preparedness on many levels and how to manage situations coming off a disruption.

4) Scheduling of Town Council Meetings, Work Sessions, and Public Hearings - Update

Mr. Nota reported on a number of projects that were authorized by Council, budgeted, and ready to proceed.

- a) Mackerel Cove restroom rehabilitation project
- b) Fort Getty rehabilitation project – including restrooms and gatehouse

An RFQ is under development for design services, and will be part of a public, staff and Council discussion, with dates to be set.

- c) East Ferry design

This project includes the sidewalks and parking area, including landscaping. This process with public engagement should proceed and dates set for public sessions.

d) Golf Course Club House workshop

Monday, November 7, 2016, at 6:00 p.m. is tentatively set for the workshop, with Architect Bill Burgin in attendance, to review the draft plans and re-engage the public.

Mr. Nota asks the Council how would like to approach the series of projects. Councilor Dickinson would like to move the East Ferry, Fort Getty, and Mackerel Cove project discussions until after the new Council is seated.

President Trocki noted the two dates set for upcoming workshops:

- October 12, 2016 at 6:00 p.m. - Rights-of-Way Public Workshop
- October 26, 2016 at 6:00 p.m. – Lawn Avenue Complex and Playground Design and Planning Input Community Workshop

Town Administrator Nota referenced the two grant awards totaling \$500,000 to support the Playground rehabilitation (\$100,000) and Lawn Avenue Complex rehabilitation (\$400,000) projects. The workshop will engage the public and help move the projects forward.

A date is needed for the East Ferry, Fort Getty, and Mackerel Cove discussion (to be scheduled after the new Council is seated). Councilor Dickinson would like the golf course discussion on its own date, and as the top priority. (November 7th at 6:00 p.m.). Vice President Meagher would like public engagement prior to finalizing any RFQ for Fort Getty so that we know what the public would like at Fort Getty. Discussion ensued of the first meeting to install the new Council, scheduled for Monday, November 21st, at which time workshop dates for East Ferry, Fort Getty, and Mackerel Cove can be set.

Mr. Nota referenced inquiries as to the next meeting of the Ordinance Review Committee, which should include the Rental Ordinance, Noise Ordinance, alcohol use on Town property, as well as other issues.

IV. PUBLIC HEARINGS, LICENSES AND PERMITS

All approvals for licenses and permits are subject to the resolution of debts, taxes and appropriate signatures as well as, when applicable, proof of insurance.

A motion was made by Vice President Meagher with second by Councilor White to open the public hearings at 7:23 pm. President Trocki, Aye; Vice President Meagher, Aye; Councilor Dickinson, Aye; Councilor White, Aye; Councilor Tighe, Aye.

A) Public Hearings

- 1) Acceptance of the Unimproved Portions of Lawn Avenue and Pemberton Avenue and Merger of One-Foot Strip of Land into Westwind Drive Right-of-Way; review and discussion and/or potential action and/or vote

- e) Resolution No. 2016-16 To accept unimproved portions of Lawn Avenue, Pemberton Avenue and a strip of land along the southerly side of Westwind Drive and to authorize Utility and Drainage Easements; review and discussion and/or potential action and/or vote

Attorney Deb Foppert of Jamestown is in attendance on behalf of applicant Dutch Harbor Development, LLC who has obtained preliminary approval through the Planning Commission of a minor subdivision for a six-acre parcel in the R40 zone located off Arnold Avenue to create two additional lots. Each resulting lot will be just shy of two acres and prohibited from further subdivision. Public sewer connections have been approved via Arnold Avenue, and water tie-in is approved for Lot C on Arnold, and Lots A and B on Westwind Drive will have private water systems. The design meets Subdivision Regulation requirements. The one foot strip along Westwind Drive added to the road was noted, creating a 51 foot wide road. Engineer Mike Darveau in attendance explained the stormwater runoff through the piping system on Lawn Avenue and Westwind Drive, diverted through the system, and out into the bay. Town Planner Bryer and Public Works Director Gray in attendance have no objections and have provided their comments prior to Planning Commission preliminary approval.

Town Council Comments. None

Public Comments. None.

A motion was made by Vice President Meagher with second by Councilor White to approve Resolution No. 2016-16. President Trocki, Aye; Vice President Meagher, Aye; Councilor Dickinson, Aye; Councilor White, Aye; Councilor Tighe, Aye.

Resolution No. 2016-16 was read by President Trocki.

- 2) Proposed Amendment of the Jamestown Code of Ordinances, Chapter 10 Animals, Article VII. Non-Domesticated Animals (new) Sec. 10-200 Feeding Non-Domesticated Animals (new); Sec. 10-201 Definitions (new); Sec. 10-202 Prohibitions (new); Sec. 10-203 Exceptions (new); and Sec. 10-204 Enforcement (new); review and discussion and/or potential action and/or vote; duly advertised in the *Jamestown Press* September 2nd edition

Numi Mitchell, PhD of Howland Avenue, Scientist leading the Narragansett Bay Coyote Study, was in attendance to speak to the issue of feeding non-domesticated animals and support adoption of the proposed ordinance. Dr. Mitchell reviewed best management practices and the guidelines regarding coyotes adopted by the Town of Jamestown ten years ago. Dr. Mitchell explained the dangers of coyotes becoming habituated, often by unintentional feeding and sometimes intentional feeding, creating a risk to humans and domesticated animals. An explanation of habituated behavior ensued. Farmers leaving livestock carcasses outside in winter months, as the ground is frozen, is problematic as it provides a major food source during breeding season. Well-fed coyotes produce more and

The resulting problem from feeding coyotes is more food equals larger, healthier litters of coyote pups, increased coyote population, and more habituated coyotes, reducing the fear factor of humans and putting people and pets in danger. The coyote referred to as Cliff in Middletown and Newport was used as an example. Dr. Mitchell stated coyotes have a wonderful function in the eco system, and should not be habituated to the human population. Feeding coyotes needs to stop, and it is important to adopt the proposed No-Feed Ordinance and enforce it after adoption. Dr. Mitchell reviewed and explained the provisions of the proposed ordinance.

Vice President Meagher commented on the problem of unsecured dumpsters as feeding locations.

Dr. Mitchell reviewed food attractants and the inherent dangers associated with food sources. The community needs to fix the root of the problem and cease feeding of coyotes immediately. People need to understand the risks, and that feeding coyotes is illegal per State law. Review of proper feeding of domesticated animals and attractants ensued.

Councilor Dickinson asked why RIDEM doesn't enforce the law? Dr. Mitchell stated it should be enforced, but isn't.

President Trocki read the Prohibitions outlined in Sec. 10-202, Exceptions outlined in Sec. 10-203, and the provision for Enforcement outlined in Sec. 10-204 for violations of the ordinance punishable by a civil penalty of from \$100 to \$500 for each day of violation in the proposed ordinance.

Dr. Mitchell stated feeding coyotes it is not acceptable. One feeder source impacts a radius of 3 ½ square miles around the feeding location.

Vice President Meagher noted increased coyote sightings in town. This ordinance is the first step in curtailing the coyote problem.

Public Comments.

David Minus of Lawn Avenue stated we need to do something to eliminate the coyotes to eliminate the problem, whatever it takes.

Councilor Dickinson noted that he learned as a member of the Tick Task Force that getting rid of the animals is only part of the problem. He supports the ordinance and how important it is to cease the feeding coyotes.

Councilor White noted that a previous Council did an education program on coyotes. This ordinance as an education program is a good way to go to control the coyote population problem.

Chief Mello feels the ordinance is a good educational tool and gives us a tool in the tool box to help control the problem.

Vice President Meagher commented people need to be educated so that they know what not to do. President Trocki asks for continued coverage on this issue by the *Jamestown Press*. We want our residents to be informed, and our residents and pets to be safe.

Dr. Mitchell will provide a copy of a safety brochure on how to deal with coyotes for public information and distribution at Town Hall.

A motion was made by Vice President Meagher with second by Councilor White to approve this ordinance. President Trocki, Aye; Vice President Meagher, Aye; Councilor Dickinson, Aye; Councilor White, Aye; Councilor Tighe, Aye.

- 3) Proposed Amendment of the Jamestown Code of Ordinances, Chapter 38 Offenses and Miscellaneous Provisions, Article V. Weapons, Sec. 38-112 Definitions (new); Sec. 38-113 Shooting Prohibited (new); Sec. 38-114 Use of Weapons in Self-Defense (new); and Sec. 38-115 Enforcement (new); review and discussion and/or potential action and/or vote; duly advertised in the *Jamestown Press* September 22nd edition

President Trocki noted the extensive ongoing discussion by the Ordinance Review Committee, public workshops, public hearing, ordinance revision, advertisement, and the revised ordinance before us for public hearing this evening. There are many opinions on how this should be regulated, and the Council would like to hear everyone's comments and make the best decision going forward.

Town Administrator Nota referenced the evolution of this Target Shooting ordinance was defined by the community. He was directed by Council to review and revise the ordinance, and in so doing, communicated with all sides of the issue. It was a challenge to develop an ordinance that addresses the concerns of the community.

President Trocki noted copies of the proposed ordinance are available for the public, and asked Town Administrator Nota to review the proposed ordinance.

Mr. Nota proceeds with an overview of the proposed Ordinance. Currently there are seven (7) ranges in town located at 21 Wildflower Lane, 109 Carr Lane, the Community Farm on Eldred Avenue, 750 North Main Road, 1191 North Main Road, 1243 North Main Road, and 1180 North Main Road.

Sec. 38-112 Definitions. The terminology that appears throughout the ordinance was reviewed.

Sec. 38-113 Registration Required. The original language was read followed by reading of the revised language as regards the sale or transfer of property where a shooting range already exists and that future use of the property will be considered a new application and subject to the limitations established in Sec. 38-118, unless the transfer is to an immediate

family member. The provisions of Sec. 38-118 are more stringent than those applied to an existing range.

Sec. 38-114 Registration Form. Mr. Nota would like to revise the language to read “The Recreational Target Range Registration Form shall be prepared and maintained by the Registrar . . . The Registrar is authorized to obtain such other relevant information as is needed to effect the purposes and objectives of this ordinance including all written permissions from property owners and occupants required under Sec. 117 and Sec. 118 of this ordinance.” This brings to light the requirement that written permission must be submitted to the Registrar with the application form. No additional insurance requirement is imposed on the property owner above what is required by the insurer.

Sec. 38-115 Recreation Term. This section remains unchanged.

Sec. 38-116 Registration Filing Requirement. This section remains unchanged.

Sec. 38-117 Shooting Prohibited. A number of clarifications are required, presently 1 through 6. No person . . . shall discharge any firearm in the Town of Jamestown, except as follows:

1. This subsection remains unchanged.
2. This subsection remains unchanged.
3. Use of a Recreational Target Range is restricted to the period between 9:00 a.m. to 6:00 p.m., Monday through Saturday and 12:00 p.m. to 4:00 p.m. on Sundays; provided, however, that all activity must cease 30 minutes before sunset on a year-round basis. This is a modification of the time shooting is allowed.
4. This subsection remains unchanged.
5. The point of discharge of any firearm shall be a minimum distance of 500 feet from:
 - a) Any dwelling or principal or accessory building on an abutters property. This new language clarifies the provision.
 - b) Any target and/or berm or backstop location shall be 500 feet from any dwelling or principal or accessory building

Vice President Meagher suggests “The point of discharge of any firearm or the location of the target (backstop or berm) shall be a minimum distance of 500 feet from any dwelling or principal or accessory building.” The phrase “~~on an abutters property~~” would be eliminated and this would clarify the provision.

6. The maximum distance from the point of discharge to the backstop structure is limited to 100 feet.

Mr. Nota continues: The setback requirements set forth in this section must be complied with if the shooter does not possess the specific written permission of the owner and occupant of the property subject to any setback provisions set forth in this ordinance to discharge a weapon within the specified setback distance.

Vice President Meagher suggests “The setback requirements described in Sec. 38-117.5 must be adhered to unless the recreational target range has written permission or approval

from the owner and occupant of any property who's dwelling or principal or accessory building is within 500 feet of the point of discharge or target backstop or berm. Said permission must be on file with the Registrar.

Mr. Nota reads the section: No person shall discharge any firearm in such fashion that the shot, bullets, arrows, darts or other missiles shall in their flight carry over, along or across the land of another, any public roadway, designated public walking path, access way, sidewalk, hiking trail, park area, or bike path, into which they shall not have written permission of the owner and occupant thereof to shoot. Such written permission shall be carried on the person at all times when engaged in the activity and shall be shown and exhibited upon request by the police.

Vice President Meagher suggests “. . . for which they do not have written permission.”

Sec. 38-118 Shooting Prohibited (Ranges Established after the effective date of this Ordinance). This is a new section and applies to potential applicants for a new range after ordinance approval, and the restrictions are more onerous.

Mr. Nota reads the section: The following provisions are applicable to all Recreational Target Ranges not established as of the effective date of this ordinance.

1. A Recreational Target Range located on private property must contain a minimum land area of no less than two (2) acres;
2. A Recreational Target Range must be specifically permitted by the property owner;
3. The point of discharge of any firearm shall be a minimum distance of 1000 feet from any dwelling or principal or accessory building, any public property, including but not limited to, public roadways, public walking/bicycling path, access way, sidewalk, hiking trail, park area, picnic area, right-of-way or beach area.

This greatly expands the required setbacks and perimeter for new ranges.

It continues: The above noted setback requirements must be complied with if the shooter does not possess the specific written permission of the owner and occupant of the property within the specified setback distance.

The last paragraph of Sec. 38-117 is then repeated as the last paragraph of Sec. 38-118, with the additional provision for the 1000 foot setback, which inhibits the potential development of new ranges.

Sec. 38-115 Use of weapons in self-defense. Mr. Nota reads the section: No provision of this chapter shall be construed as prohibiting the use of licensed armed guards or of firearms by private persons in the Town for the protection or defense of person or property in accordance with Rhode Island Law.

Sec. 38-116 Enforcement. Mr. Nota reads the section: Any person violating the provisions of this section shall be punished as provided in Sec. 1-15.

There are a number of changes in the terminology and language as noted. Six of the established seven ranges will be affected, as written permission from an abutter is a requirement in the proposed ordinance. It appears only one range may have concern for obtaining abutter written permissions to continue. There are no interested parties to establish a new range under the new ordinance.

President Trocki noted her struggle with this ordinance, as she is trying to find middle ground in her various roles and as a mediator, which is causing consternation, and she is unsure this ordinance works. She tries to be open-minded, but is having difficulty with the activity which is dangerous on one hand, but has been a long-standing tradition with a good public safety record on the other. She would like hear from legal counsel as there are questions on safety and liability. How do we make our town safer and less exposed to liability?

Solicitor Brochu commented it is important to be clear as to the goals of what this ordinance wants to achieve. What does safety mean? This ordinance contains the registration component and the distance component for shooting. Is this ordinance achieving the safety goal, and how is it achieving that? Regarding liability, this is a difficult question – what is our exposure – this asking for an answer not based on any facts. This is a regulatory area where currently the town has no duty to regulate other than what is outlined in State law. Any time a regulatory program is undertaken, there is exposure. Is the ordinance lawful? Achieving what is intended? How does it affect property owners' rights? The language needs to be clear so that everyone understands the ordinance. Does the Town have exposure due to enactment of the ordinance related to management or enforcement of the ordinance? Once the activity is regulated it becomes an allowed activity, which is now too speculative to address.

Councilor Dickinson questions discharge, which State law regulates. Solicitor Brochu notes that hunting is regulated by RIDEM and requires a license. What does the ordinance require and does it regulate safety or is it registration? As written the ordinance does not determine whether a range is safe or under what circumstances that determination would be made. The intent is more for registration rather than permitting the ranges under a regulatory program. Mr. Nota stated the registration is for public notice so that people know where ranges are located. This is setting the framework for allowing the activity. The ordinance is written to eliminate activity from most areas of town and will hold new ranges to a higher setback. Over time there would be fewer ranges. President Trocki noted this is the area she is struggling with. She values the activity enjoyed by many for a long time, but our community has expanded and changed. There are best practices, safety measures, and alternatives, and this is not an easy issue.

Councilor Dickinson is of the opinion the ordinance will give people a false sense of security. This is a managed activity by State and Federal regulation and the ordinance will not solve the predominant problem and confuse residents, as it will not eliminate discharging a firearm and citizens will not know if it is coming from hunting or target shooting.

Councilor White feels we should be concerned for safety and liability. The solutions could be: prohibit target shooting in Jamestown, and there is no liability; do nothing, and there is no liability. This is an activity on private property, and we are not responsible for activities on private property unless it violates a law. The ordinance tries to control but not prohibit the activity, which has a great safety record for the seven ranges over many years. We need to know what residents feel about the ordinance and if they are agreeable to a compromise to allow the activity to continue.

Public Comments.

Randall White of Westwood Road stated that no matter how well intentioned, the activity is inherently dangerous. Accidents happen. The ordinance does not regulate the size of weapons or caliber of ammunition used. He is deeply concerned and the argument for regulating this activity is public safety. Areas of the ordinance concern him, including the distinction between the 500 ft. and 1000 ft. setbacks for existing and new ranges. He feels this does not have a place in this consideration and is problematic. The setbacks are meaningless if there is written permission from neighboring property owners. The liability and exposure provides no comfort level for residents. The only responsible thing in the name of public safety is to enact an ordinance that prohibits all target shooting. This ordinance doesn't work.

Gayen Thompson of Grinnell Street stated she has learned a lot from the comments made. She expressed concern for public safety. Regulations imposed on drivers for licensing and the requirements to continue to drive were noted, and yet there are still many accidents. This is a dangerous activity and the proposed ordinance has no provisions for the size or type of weapons used and the distance a bullet can travel; the Island is 9 miles long by 1 mile wide. The ordinance should require a backstop or berm behind a target as a safety precaution. This is a difficult decision.

Bruce Dickinson of Arnold agrees with much Gayen said, except he doesn't believe it is inherently dangerous. He agrees some type of regulation is required. Chief Mello noted if someone was shooting on property he had no recourse to prohibit it. We need some type of regulation, but this goes beyond that. Sec. 18-117 prohibits shooting except for legal hunting as defined by state and local regulation. We should take on what the State has done for us without a backstop, and add it to something that has a backstop, giving the police recourse and guidelines. This ordinance goes above and beyond what is necessary.

Mike diAngeli of Court Street stated he lives next to the Wildflower Lane shooting range. Hunting is not target shooting. It is a nuisance, not pleasant, and reduces property values, in addition to being a public safety issue. No one will buy his property if it is next to a shooting range. The ordinance is very unclear. He feels the Chief of Police should inspect the ranges before they are registered.

Chris Cannon of East Shore Road referenced his comments of six months ago. This is a public safety issue that needs to be addressed. He expressed concern that bullets from target shooting can travel 1 to 3 miles when a target is missed. There is no comparison

between hunting and target shooting, and he has no problem with hunting or gun ownership. There is no definition in the ordinance of a compact area, making it hard to enforce. The proposed ordinance would allow shooting for up to 3000 hours a year with multiple rounds. The safety measures outlined need a lot of definition to provide protection. The Town should operate a target range so that it will be compliant. Mr. Cannon referenced the NRA manual and their recommendations for target shooting ranges. He maintains his position that only target shooting at a safe professionally run range and not in someone's backyard is the best option for the safety of Jamestown. If the Council will not prohibit target shooting in Jamestown, then enacting this ordinance is better than no regulation; taking some action is better than taking no action.

Paul Sprague of Mast Street stated Mr. deAngeli and Mr. Cannon nailed it. This is not about safety, it is really about noise. He referenced ads that suggest target shooting is putting children at risk while they play. There are no ranges near playgrounds. Safety cannot be argued, existing private ranges have a 100% safety record, and there has never been an accident. People move here because it is a beautiful place. As someone who grew up here, why did they move here? Don't try to take something away because you did not do your homework before you moved here. He feels all existing ranges should be grandfathered. As far as 3000 hours of shooting, who has enough money to purchase ammo to shoot that much? This is not about safety, it is an issue of noise.

Quentin Anthony of Bay View Drive is here to speak on behalf of the Land Trust, which owns 500 acres of open space representing over 150 properties. There are disturbing areas in the ordinance, as referenced by Randy White. Many residents walk through the Land Trust property, which does not have the same rights as properties with structures on them. The Land Trust cannot give permission or deny it to an existing or prospective shooting range. There is an existing range next to the Land Trust property, and there may be as many as 50 people a day walking, running, and hiking on the Land Trust property. It should be a safe place, and he requests to have the same rights as a property owner.

Merrill Sherman of Walnut Street suggested the first change referenced by Vice President Meagher regarding the 500 ft. should be an "and" and not an "or". She does not understand the discussion of creating liability by passing the ordinance. Our State and Federal government passes regulations that set minimum standards, and somehow they don't seem to be liable. She doesn't see where it creates liability for the Council and they should be comfortable setting minimum standards. The facts are clear on how bullets can travel, and it is okay to set standards. If an abutter is comfortable granting permission for a neighbor to shoot on their property, why does the Town want to deny it. The Town has made a lot of progress with the ordinance and has done a good job. Such ordinances are not uncommon, it would be sensible to pass this, and there is always room for improvement. The real liability is in doing nothing, and adopting this ordinance is the sensible thing to do.

Doc Clark of Ledge Road agreed with Ms. Sherman; the town is not avoiding liability by not having any regulation. Hunting uses different weapons than target shooting and

existing hunting ordinances cannot be used for target shooting, and both safety and noise should be regulated in the ordinance. The Island has changed, this was formerly a farming community and now it is a suburban community, and the rationale there has never been regulation and therefore we should not have any because of tradition isn't valid. Sec. 38-118 should make clear that previous sections apply to it as well as the information under it. This ordinance is not perfect, but it is good, and it should be cleaned up and enacted. Do not spend time trying to make it perfect.

Steven Sparhawk of Dumpling Drive stated he looked up the punishment as outlined in Sec. 1-15 of the Code of Ordinances, which states “. . . shall be punished by a fine of not more than \$500 or by imprisonment of not more than 30 days”. For shooting a pellet gun in my yard you're going to put me in jail and make me a criminal. Chief Mello stated that it could be up to that amount at the discretion of the Judge in District Court. As a NRA Certified Range Safety Officer, the incidence of stray bullets has been on long-distance rifle ranges. The ordinance proposes 100 feet and he suggests making it 75 feet, which is 25 yards. On a range like that it is almost impossible to shoot a bullet over the berm. His biggest issue is with the State law that classifies BB guns and pellet guns as firearms, as he shoots his pellet gun ever other day since he lived here, has never had an issue, and would hate to see that activity end.

Phil Allen of North Road stated he enjoys trap shooting, has done it his whole life, and has always handled guns appropriately. He likes antique weapons, loves living here, and enjoys trap shooting on Columbus Day. He shoots from 10:00 a.m. to 12:00 noon, puts the firearms and ammunition away and locks it up, and enjoys the activity.

Nick Robertson of Carr Lane stated the common guys can come up with a solution and lawyers aren't the only ones who can make decisions. The reason the safety records for the shooting ranges is so good is because the shooters have practiced safety rules and use of firearms. You have to know where bullets go and that is what makes the difference. The Council is on the right track and should not get intimidated by liability. Someone will take a case no matter how ridiculous. You may want to see how Jamestown feels about a shooting range and put it on a ballot, and a location can be found once it is determined there is support for it. He believes in safety and people who shoot here do too. Keep doing what you are doing.

Nick Lapinski of Hammett Court stated he is the son of a law enforcement officer and marksman, and without informal ranges, our youth won't learn to shoot, wildlife population won't be controlled, and the activity will not be carried on. Other activities are dangerous, such as bicycling and swimming. This is a good thing and it should not be eliminated.

Ken Newman of Avenue B stated the proposed ordinance is positive. It safeguards the existing ranges and in a way grandfathers them in and allows for prospective ranges to be held to a higher standard. He likes the ordinance the way it is with the provisos for the existing ranges and potential ranges. The idea of written permission is important and goes

a long way to simplify this for the police chief. This is a strong first step, it recognizes the community has changed, and takes it into consideration the tradition here.

Ray Ianetta of Maple Avenue stated for 30 years he lived between two ranges and he was never afraid of being shot. Phil Willis on one side, very respectful and safe, shot two hours max. Sandy Kane on the other side, ran a gun shop, and at times it went on all afternoon. It was the noise he didn't like. He suggests the Council limit the activities and consider cutting back on the hours allowed and exclude Sundays.

Town Council Comments:

Vice President Meagher stated Councilor White put it well and Ken stated it very well. As Chris stated something is better than nothing. This is a start and the concerns raised by Randy make me want more information. We can't create a liability-free world. The distinction between the 500 feet and 1000 feet can be concerning, as you can't put public safety in the hands of a neighbor. She was ready to come to vote in favor of the ordinance, would like to do something as it is important, but questions were raised that have merit and she is concerned.

President Trocki stated she has a problem with treating two similarly situated people differently. The person she most aligns with is Councilor Dickinson, but their approaches are from opposite directions. She leans towards prohibiting the activity, as it is about safety, and noise can be dealt with by a revised noise ordinance or by neighbors in court. She would like a strong regulation based on safety, and has learned a lot from tonight's discussion and comments.

Vice President Meagher noted Quentin's concern for the Land Trust property and safety for those who use it. We can't make it perfect, and enough questions were raised so that she would like revisions to the ordinance, and review at a later date. Prohibiting the activity is not her intention.

Councilor White agrees with Vice President Meagher. He is not ready to vote on this tonight. He doesn't see a problem with existing ranges, as they have a great safety record. They have a lesser radius as they have already demonstrated they can operate a safe range.

Paul Sprague stated the current ranges are 100% safe and have a proven history. Don't take away the activity because people don't like the noise, as it is not fair.

Councilor White stated we have the ordinance and he recommends making changes, including whether a place is dangerous and addressing properties without structures on it. We might want to limit hours and perhaps current operators can come up with something a little more restrictive on the hours of operation. It needs work.

President Trocki stated we are having this discussion in compliance with the Open Meetings Law. We are not having discussions behind closed doors. This is what is

proposed, it is open government and transparent, and we speak as five people responsible for public safety.

Town Administrator Nota stated everyone assumes the dual standard of 500 feet and 1000 feet is predicated on increased safety. The 500 feet was following RI State law on hunting. Increasing that number was done to limit the number of ranges from proliferating in the future.

Councilor Dickinson asked for information from Doc Clarke. Doc questioned the process and modifying the ordinance. President Trocki explained the open meeting process and procedures that need to be followed. Councilor Dickinson stated from the beginning he was open to regulating the activities, as are those who engage in the activity. He respects the opinions of others, and most people who engage in the activity in Jamestown are respectful of their neighbors. The activity may be more offensive to people here, but he doesn't know of shooters who want to do this for more than an hour. Other activities, including hunting, are more dangerous than target shooting. The State regulates these activities and is successful at it, and we should look at their regulations and incorporate them into ours. In hunting you can be 500 feet from a dwelling and can shoot in any direction. With target shooting it is in one direction, with a backstop added, and is a safer activity. We are already moving in the right direction, and reaching out to the people we will come up with an improved ordinance. People can still hunt on properties, even if target shooting is prohibited. Let's make the activity safe, look at those who engage in the activity, and look at what the State does.

Solicitor Brochu stated the public hearing could be continued or the ordinance could be rewritten and a new public hearing scheduled and put before the public. It would give more latitude to have the revised document for review for a future public hearing.

President Trocki stated there were many good points made this evening. Everyone contributed to the discussion, which is important, and it will result in a better outcome for this ordinance.

Gayen Thompson asked about regulations for the current operators and if there can be restrictions placed on them, including a backstop. President Trocki stated without an ordinance no restrictions or requirements can be placed on the operators.

From the audience: Most of the operators already have backstops.

Councilor Dickinson stated responsible people put up a backstop. President Trocki stated she would like proof of liability insurance. Councilor Dickinson noted the property owner is liable. If they expose themselves to risk, they may lose their property.

A motion was made by Vice President Meagher with second by Councilor White to close this hearing and set a date to have a new public hearing on this issue or a new public discussion on this issue within 90 days.

Discussion. Based on the discussion, we know a new public hearing or discussion is needed.

Back to the vote on the motion. **President Trocki, Aye; Vice President Meagher, Aye; Councilor Dickinson, Aye; Councilor White, Aye; Councilor Tighe, Aye.**

Town Administrator Nota asked if the Council would like it sent back to the Ordinance Review Committee. President Trocki commented this should be left to the people who have more knowledge of this activity. Town staff should review these minutes and take the ideas and use them to develop an ordinance we can work with.

V. OPEN FORUM

Please note that, under scheduled requests to address, if the topic of the address is available to be put on the agenda, the Council may discuss the issue

- A) Scheduled to address. None.
- B) Non-scheduled to address.

Alan Katz of Westwind Drive stated the Dutch Harbor neighbors have a Communication on the agenda signed by himself and his neighbors, which he read. Their former scenic vista is now an active commercial aquaculture operation with numerous cages and marker buoys. They are requesting Town Council support in the form of a letter to CRMC objecting to the latest aquaculture expansion. Vice President Meagher stated this is adjudicated by CRMC, the Town is not part of the process, and is not in charge of the hearings. They need to contact CRMC so that they can be notified of those meetings. Town Administrator Nota referenced the process through CRMC and that the Town very seldom has grounds to interfere with that process. Mr. Nota will communicate with Mr. Katz to provide information, and this will be placed on a future agenda for follow-up. The proposed activity in question is to add winter kelp in addition to oysters in their aquaculture project. As this is a Communication, the Council can listen but cannot act.

VII. UNFINISHED BUSINESS

None.

VIII. NEW BUSINESS

- A) Award of Bid: Sustainable Jamestown Plan to Horsley Witten Group of Providence, RI for an amount not to exceed \$63,180 as recommended by the Proposal/Qualification Team (Planner Bryer, Commissioner Cochran, Commissioner Pendlebury, Commissioner Prestigiacomio [Alternate], Town Administrator Nota)

Town Planner Lisa Bryer in attendance addressed the award of bid and explained the process before the Planning Commission since 2012, which began as an Economic Development Plan. As the discussion continued it was realized there are many economies in Jamestown and sustainability is the connection of all issues in Jamestown as outlined in the Comprehensive Plan, and the focus was changed to a Sustainability Plan. An RFP

was prepared and seven bids received, with three firms interviewed. Horsley Witten had the lowest qualified, responsive bid and the greatest capabilities. Town Administrator Nota feels this is a good fit and supports the recommendation.

A motion was made by Councilor Dickinson with second by Vice President Meagher to award the bid to Horsley Witten Group for an amount not to exceed \$63,180. President Trocki, Aye; Vice President Meagher, Absent; Councilor Dickinson, Aye; Councilor White, Aye; Councilor Tighe, Aye.

X. CONSENT AGENDA

An item on the Consent Agenda need not be removed for simple clarification or correction of typographical errors. Approval of the Consent Agenda shall be equivalent to approval of each item as if it had been acted upon separately.

A motion was made by Councilor Tighe with second by Councilor Dickinson to approve and accept the Consent Agenda. President Trocki, Aye; Vice President Meagher, Absent; Councilor Dickinson, Aye; Councilor White, Aye; Councilor Tighe, Aye.

The Consent Agenda approved consists of the following:

- A) Adoption of Council Minutes
 - 1) September 20, 2016 (regular meeting)
- B) Minutes from Boards, Commissions and Committees
 - 1) Jamestown Harbor Commission (07/13/2016)
 - 2) Jamestown Harbor Commission (08/10/2016)
 - 3) Jamestown Zoning Board of Review (08/23/2016)
- C) CRMC Notices
- D) Abatements/Addenda of Taxes
 - Total Abatements: \$4,585.13 Total Addenda: \$5,445.31
 - 1) Motor Vehicles – Abatements to 2016 Tax Roll
 - Account/Abatement Amount**
 - a) 03-0137-28M \$ 62.15
 - b) 13-1562-47M \$ 46.10
 - c) 10-0301-10M \$ 65.74
 - 2) Properties – Abatements to 2016 Tax Roll
 - Account/Abatement Amount**
 - a) 04-0964-50 \$ 308.02
 - b) 11-0455-20 \$ 410.12
 - c) 12-0236-50 \$ 124.41
 - d) 15-0030-12 \$ 557.70
 - e) 15-0248-00 \$ 589.45
 - f) 18-0260-00 \$ 689.83
 - g) 18-0817-35 \$ 528.53
 - h) 19-1295-98 \$ 805.83
 - i) 23-1007-10 \$ 397.25
 - 3) Properties – Addenda to 2016 Tax Roll

Account/Abatement Amount

- | | | | |
|--|----|------------|------------|
| | a) | 08-0648-00 | \$ 386.70 |
| | b) | 09-0028-00 | \$1,506.48 |
| | c) | 13-0406-00 | \$1,327.88 |
| | d) | 18-0785-04 | \$1,732.25 |
| | e) | 22-0293-12 | \$ 492.00 |
- E) Finance Director's Report
- F) One Day Event/Entertainment License
- 4) Applicant: Jamestown Parks and Recreation
Event: 10th Annual Skatefest
Date: October 7, 2016
Location: Lawn Avenue Skate Park
- 5) Applicant: Jamestown Rotary Club
Event: 41st Annual Jamestown Classic Bike Race
Date: October 10, 2016
Location: Fort Getty Pavilion; streets of Jamestown
- 6) Applicant: Jamestown Parks and Recreation
Event: 28th Annual Jack-O-Lantern Jog 5K
Date: October 29, 2016
Location: Fire Station; streets of Jamestown

XI. COMMUNICATIONS, PETITIONS, AND PROCLAMATIONS AND RESOLUTIONS FROM OTHER RHODE ISLAND CITIES AND TOWNS

A motion was made by Councilor Dickinson with second by Councilor Tighe to receive the Communications and Resolutions and Proclamations. President Trocki, Aye; Vice President Meagher, Aye; Councilor Dickinson, Aye; Councilor White, Aye; Councilor Tighe, Aye.

The Communications and Resolutions and Proclamations received consists of the following:

- A) Communications
- 1) Letter of Commander Leslie Kurtz, Arnold Zweeir Post 22, American Legion, expressing support for re-evaluation of the Town's Veterans' Tax Abatement
 - 2) Letter of Burrillville Town Council requesting Jamestown Town Council adoption of a Resolution Opposing the Siting of the Clear River Energy Center in Burrillville, RI
 - 3) Letter of Dutch Harbor neighbors re: aquaculture activities and the effects on adjacent property owners
 - 4) Letter of Nonie Drexel supporting adoption of the proposed Town ordinance to regulate private shooting ranges in Jamestown
 - 5) Letter of Richard and Cynthia Trask supporting adoption of the proposed Town ordinance to regulate shooting ranges in Jamestown
- B) Resolutions and Proclamations of other Rhode Island cities and towns

- 1) Resolution of the Barrington Town Council Supporting the Goals of the Rhode Island Energy Challenge
- 2) Resolution of the Burrillville Town Council Opposing the Siting of the Clear River Energy Center in Burrillville, RI

XII. AGENDA ITEMS FOR THE NEXT MEETING AND FUTURE MEETINGS

Tax Abatements for Veterans will be on the next agenda.

XIII. EXECUTIVE SESSION

None.

XIV. ADJOURNMENT

A motion was made by Vice President Meagher with second by Councilor Dickinson to adjourn. President Trocki, Aye; Vice President Meagher, Absent; Councilor Dickinson, Aye; Councilor White, Aye; Councilor Tighe, Aye.

The Jamestown Town Council adjourned the regular meeting at 10:25 p.m.

Attest:

Cheryl A. Fernstrom, CMC, Town Clerk

Copies to: Town Council
 Town Administrator
 Finance Director
 Town Solicitor

TOWN COUNCIL SPECIAL MEETING
October 6, 2016

I. ROLL CALL

Town Council Members present:

Kristine S. Trocki, President
Mary E. Meagher, Vice President
Blake A. Dickinson
Michael G. White
Thomas P. Tighe

Also in attendance:

Andrew E. Nota, Town Administrator
Peter D. Ruggiero, Town Solicitor
Cheryl A. Fernstrom, Town Clerk

II. CALL TO ORDER

Council President Trocki called the special joint meeting of the Jamestown Town Council to order at 5:30 p.m. in the Town Administrator's Office of the Jamestown Town Hall at 93 Narragansett Avenue.

III. NEW BUSINESS/EXECUTIVE SESSION

The Town Council may seek to go into Executive Session to discuss the following items:

- A) Pursuant to RIGL §42-46-5(a) Subsection (1) Personnel (Town Administrator's performance review); review and discussion and/or potential action and/or vote in executive session and/or open session

A motion was made by Vice President Meagher with second by Councilor Tighe to enter into Executive Session at 5:31 p.m. pursuant to RIGL §42-46-5(a) Subsection (1) Personnel.

Pursuant to RIGL §42-46-5(a) Subsection (1) Personnel, the following vote was taken: President Trocki, Aye; Vice President Meagher, Aye; Councilor Dickinson, Aye; Councilor White, Aye; Councilor Tighe, Aye.

The Town Council reconvened the special meeting at 6:54 p.m. President Trocki announced that no votes were taken in Executive Session.

A motion was made by Vice President Meagher with second by Councilor Tighe to seal the Minutes of Executive Session. President Trocki, Aye; Vice President Meagher, Aye; Councilor Dickinson, Aye; Councilor White, Aye; Councilor Tighe, Aye.

IV. ADJOURNMENT

A motion was made by Councilor Tighe with second by Vice President Meagher to adjourn. President Trocki, Aye; Vice President Meagher, Aye; Councilor Dickinson, Aye; Councilor White, Aye; Councilor Tighe, Aye.

The special meeting was adjourned at 6:55 p.m.

Attest:

Cheryl A. Fernstrom, CMC, Town Clerk

Copies to: Town Council
 Town Administrator
 Finance Director
 Solicitor

**TOWN COUNCIL/LIBRARY BOARD OF TRUSTEES
SPECIAL JOINT MEETING
October 6, 2016**

I. ROLL CALL

Town Council Members present:

Kristine S. Trocki, President
Mary E. Meagher, Vice President
Blake A. Dickinson
Michael G. White
Thomas P. Tighe

Library Board of Trustees Members present:

Mary Lou Sanborn, Chair
Peter Carson, Treasurer
Paul Housberg
Christopher Walsh
Christian Infantolino
Jennifer Cloud
Marianne Kirby

Also in attendance:

Andrew E. Nota, Town Administrator
Peter D. Ruggiero, Town Solicitor
Frank Sallee, Library Trustees Solicitor
Cheryl A. Fernstrom, Town Clerk

II. CALL TO ORDER

Council President Trocki and Library Board of Trustees Chair Sanborn called the special joint meeting of the Jamestown Town Council and Jamestown Philomenian Library Board of Trustees to order at 7:04 p.m. in the Jamestown Philomenian Library Sidney L. Wright Museum Room at 26 North Road.

III. NEW BUSINESS/EXECUTIVE SESSION

The Town Council may seek to go into Executive Session to discuss the following items:

- A) Pursuant to RIGL §42-46-5(a) Subsection (1) Personnel (Library/Town Administrator communications); review and discussion and/or potential action and/or vote in executive session and/or open session

A motion was made by Councilor Tighe with second by Councilor Dickinson to enter into Executive Session at 7:04 p.m. pursuant to RIGL §42-46-5(a) Subsection (1) Personnel.

Pursuant to RIGL §42-46-5(a) Subsection (1) Personnel, the following vote was taken: President Trocki, Aye; Vice President Meagher, Aye; Councilor Dickinson, Aye; Councilor White, Aye; Councilor Tighe, Aye.

A motion was made by Trustee Carson with second by Trustee Infantolino to enter into Executive Session at 7:04 p.m. pursuant to RIGL §42-46-5(a) Subsection (1) Personnel.

The Town Council and Library Board of Trustees reconvened the special joint meeting at 7:38 p.m. Council President Trocki and Library Board of Trustees Chair Sanborn announced that no votes were taken in Executive Session.

A motion was made by Vice President Meagher with second by Councilor Tighe to seal the Minutes of Executive Session. President Trocki, Aye; Vice President Meagher, Aye; Councilor Dickinson, Aye; Councilor White, Aye; Councilor Tighe, Aye.

A motion was made by Trustee Walsh with second by Trustee Housberg to seal the Minutes of Executive Session. Chair Sanborn, Aye; Trustee Carson, Aye; Trustee Housberg, Aye; Trustee Walsh, Aye; Trustee Infantolino, Aye; Trustee Cloud, Aye; Trustee Kirby, Aye.

IV. ADJOURNMENT

A motion was made by Councilor Tighe with second by Vice President Meagher to adjourn. President Trocki, Aye; Vice President Meagher, Aye; Councilor Dickinson, Aye; Councilor White, Aye; Councilor Tighe, Aye.

A motion was made by Trustee Housberg with second by Trustee Walsh to adjourn. Chair Sanborn, Aye; Trustee Carson, Aye; Trustee Housberg, Aye; Trustee Walsh, Aye; Trustee Infantolino, Aye; Trustee Cloud, Aye; Trustee Kirby, Aye.

The special joint meeting was adjourned at 7:39 p.m.

Attest:

Cheryl A. Fernstrom, CMC, Town Clerk

Copies to: Town Council
 Town Administrator
 Finance Director
 Solicitor



**Town of Jamestown
Tax Assessor**

**93 Narragansett Avenue
Jamestown, RI 02835**

**Phone: 401-423-9802
Email: kgray@jamestownri.net**

To: PRESIDENT, JAMESTOWN TOWN COUNCIL

From: JAMESTOWN TAX ASSESSOR

Subject: ABATEMENTS/ADDENDA OF TAXES FOR THE **OCTOBER 18, 2016** MEETING

MOTOR VEHICLE ABATEMENT TO 2011 TAX ROLL

#01-0196-73M Allied Plumbing & Heating	Motor Vehicles –2007 Chevys Reg. #199352 & #201005, 2008 Chevy #044951 – Owner deceased	\$427.58
---	--	----------

MOTOR VEHICLE ABATEMENT TO 2012 TAX ROLL

#01-0196-73M Allied Plumbing & Heating	Motor Vehicles –2007 Chevys Reg. #199352 & #201005, 2008 Chevy #044951 – Owner deceased	\$406.65
---	--	----------

MOTOR VEHICLE ABATEMENT TO 2013 TAX ROLL

#01-0196-73M Allied Plumbing & Heating	Motor Vehicles –2007 Chevys Reg. #199352 & #201005, 2008 Chevy #044951 – Owner deceased	\$292.72
---	--	----------

MOTOR VEHICLE ABATEMENT TO 2014 TAX ROLL

#01-0196-73M Allied Plumbing & Heating	Motor Vehicles –2007 Chevys Reg. #199352 & #201005, 2008 Chevy #044951 – Owner deceased	\$282.64
---	--	----------

MOTOR VEHICLE ABATEMENT TO 2015 TAX ROLL

#01-0196-73M Allied Plumbing & Heating	Motor Vehicles –2007 Chevys Reg. #199352 & #201005 – Owner deceased	\$33.08
---	--	---------

MOTOR VEHICLE ABATEMENTS TO 2016 TAX ROLL

#07-0844-30M Greco, Marie C.	Motor Vehicle – 2010 Cadillac Reg. #ACE Vehicle sold on 9-24-15	\$35.52
#12-0841-15M Loomis, Michael	Motor Vehicle – 2015 Subaru Reg. #BR 506 Soldier/Sailor Exemption	\$139.37

REAL PROPERTY/TANGIBLE ABATEMENTS TO 2016 TAX ROLL

#02-1390-00 Brown, Janet M.	Plat 2, Lot 223 – Property transfer 9-20-16 to Account #02-0227-50	\$6,181.30
#04-0775-75 Douglas Enterprises, Ltd	Plat 3, Lot 328 – Property transfer 9-23-16 to Account #19-1371-00	\$641.19
#04-1037-00 Dutton, Kathryn Wooley	Plat 8, Lot 145 – Property transfer 9-30-16 to Account #11-0090-00	\$8,165.80
#06-0110-65 Farrelly, Noreen	Plat 14, Lot 278 – Property transfer 9-12-16 to Account #08-0003-77	\$5,925.61
#07-0816-90 Gray, Elizabeth Janet & David Benjamin	Plat 8, Lot 152 – Property transfer 9-23-16 to Account #14-0045-90	\$3,463.27
#07-0894-00 Greenhalgh, Debra J.	Plat 14, Lot 321 – Property transfer 9-27-16 to Account #13-0640-10	\$3,725.70
#10-0010-20 Jackvony, Bernard A.	Plat 8, Lot 488-202 – Property transfer 9-6-16 to Account #02-1138-10	\$5,622.17
#11-0514-00 Knudsen, Robert E.	Plat 15, Lot 372 – Property transfer 9-29-16 to Account #12-1037-00	\$5,297.56
#12-0448-75 Leonard, Barbara M. (Estate of)	Plat 8, Lot 29 – Property transfer 9-30-16 to Account #20-0506-00	\$18,497.03
#13-0326-00 Malouin, Fernand E., Trustee	Plat 15, Lot 210 – Property transfer 9-14-16 to Account #11-0408-00	\$7,260.66
#13-0326-00 Malouin, Fernand E., Trustee	Plat 15, Lot 212 – Property transfer 9-14-16 to Account #11-0408-00	\$11,534.36
#13-0523-97 Marrinan, Joseph P. III & Janet M.	Plat 3, Lot 529 – Property transfer 9-16-16 to Account #13-1956-40	\$3,269.84
#13-0525-50 Marsh, Lauren R. Trust	Plat 6, Lot 43 – Property transfer 9-14-16 to Account #04-0083-02	\$2,582.58
#19-0593-00 Shapiro-Thomas Trust	Plat 8, Lot 316 – Property transfer 9-30-16 to Account #03-0748-00	\$4,782.71

REAL PROPERTY/TANGIBLE ADDENDA TO 2016 TAX ROLL

#02-0227-50 Barrett, Rowland & Nancy	Plat 2, Lot 223 – Property transfer 9-20-16 from Account #02-1390-00	\$6,181.30
#02-1138-10 Brakenhoff, Noel	Plat 8, Lot 488-202 Property transfer 9-6-16 from Account #10-0010-20	\$5,622.17
#03-0748-00 Cintra Jamestown Trust	Plat 8, Lot 316 - Property transfer 9-30-16 from Account #19-0593-00	\$4,782.71
#04-0083-02 Damle Realty, LLC	Plat 6, Lot 43 – Property transfer 9-14-16 from Account #13-0525-50	\$2,582.58
#08-0003-77 Hackman, Peter & Prestigiacomo, Dana	Plat 14, Lot 278 – Property transfer 9-12-16 from Account #06-0110-65	\$5,925.61
#11-0090-00 Kazan, Michael A. & Herman, Beth M.	Plat 8, Lot 145 – Property transfer 9-30-16 from Account #04-1037-00	\$8,165.80
#11-0408-00 Kirmil, Scott & Adrienne Perry et Perry, Patricia R.	Plat 15, Lot 210 – Property transfer 9-14-16 from Account #13-0326-00	\$7,260.66
#11-0408-00 Kirmil, Scott & Adrienne Perry et Perry, Patricia R.	Plat 15, Lot 212 – Property transfer 9-14-16 from Account #13-0326-00	\$11,534.36
#12-1037-00 Lyons-Delany, LLC	Plat 15, Lot 372 – Property transfer 9-29-16 from Account #11-0514-00	\$5,297.56
#13-0640-10 Marzilli, Lisa	Plat 14, Lot 321 – Property transfer 9-27-16 from Account #07-0894-00	\$3,725.70
#13-1956-40 Moore, Wayne D., Trustee	Plat 3, Lot 529 – Property transfer 9-16-16 from Account #13-0523-97	\$3,269.84

#14-0045-90 Neagoy, Nicholas C.	Plat 8, Lot 152 – Property transfer 9-23-16 from Account #07-0816-90	\$3,463.27
#19-1371-00 Stamouli, Sean M. & Nelson, Casey	Plat 3, Lot 328 – Property transfer 9-23-16 from Account #04-0775-75	\$641.19
#20-0506-00 Torre, Robert C.	Plat 8, Lot 29 – Property transfer 9-30-16 from Account #12-0448-75	\$18,497.03

TOTAL ABATEMENTS	\$88,567.34
TOTAL ADDENDA	\$86,949.78

RESPECTFULLY SUBMITTED,

Kenneth S. Gray

KENNETH S. GRAY,
TAX ASSESSOR



September 1, 2016

Offices of the Town Council
Town Hall
93 Narragansett Ave
Jamestown, RI 02835

Dear Council Members,

In accordance with RI State Statute 42-105-11, we have enclosed a copy of our fiscal year ended March 31, 2016 annual audit report. I am pleased to report that we received an unmodified opinion and had no significant deficiencies or material weaknesses.

If you would like an electronic copy of the audit report, please contact me at aadkins@discovernewport.org.

Sincerely,

A handwritten signature in black ink, appearing to read "Alyson C Adkins", written in a cursive style.

Alyson C Adkins
Director of Finance and Human Resources

Enclosures
Cc: Frank Sallee

David and Mary Dacquino
519 Main Street
Dunstable, MA 01827

Town of Jamestown
Town Offices
93 Naragansett Avenue
Jamestown, RI 02835

Attn: Andy Nota – Town Manager

Re: The street light on the corner of Walcott Avenue and Brook Street

Dear Andy,

As follow up to our discussions with you and Michael Gray, Dave and I would like to propose a solar light to replace the existing electric street light at the above location. Two additional poles are required to power this unsightly light which obstruct the view to the water of many properties with views to East Ferry. Historically, this light is often non- functioning, as it is now, and a previous storm this year had caused the wire to fall on the road creating a safety hazard.

We are aware that Jamestown is embarking on a detailed review of alternative lighting proposals to go to LED type electric streetlights, as well as taking ownership of them from National Grid. We are proposing a pilot program for a solar LED street light at this location. It will be funded by ourselves and our neighbors and can conform to the amount of lumens and illumination radius you feel would be required for this location.

We believe this to be an excellent data point as you continue your study of the lighting project. This is unanimously supported by all neighbors in sight of the pole as well as many others in the neighborhood. We understand that the lighting project may eventually recommend the replacement of this light with the standardized option that town selects, hence, this is a pilot project funded by the neighborhood.

Additionally, the attached solar light option comes with a three year warranty, and requires virtually no maintenance. We are proposing a 25ft aluminum bronze color pole, that will blend in with the surrounding foliage, beautify the views for all, increase safety in storms and have no operational cost to town. This will afford town the opportunity to fully assess the attributes and viability of solar street light options.

David and I have talked to many neighbors and the consensus is they would like to see Jamestown move toward more “green” technology for our lighting plan. No one would argue in favor of unsightly overhead wires and poles, especially in consideration of the significant investments many residents are making to their properties in town, especially those along the waterfront. We are in fact, commencing the rebuilding project of our home at 2 Walcott Ave, this fall. We are excited about installing an efficient and environmentally friendly geothermal heating and air conditioning system in what will be our permanent home in Jamestown.

Certainly, David and I are spearheading this project as the removal of the electrical poles will have the most dramatic improvement for our newly constructed home. One pole, in particular would be squarely in our near field of view, not fifteen feet from our turret windows. We have gone to considerable expense to go underground with our utilities from the back of our property in preparation of this project.

To sum up, we are requesting permission to have the three poles removed, (including the pole which has the current streetlight) and have it replaced with the solar option we proposed. As there is lead time, we

would like to order the light soon. Allowing this will also greatly facilitate the demolition of existing, and construction of our new home.

Your sincere consideration in this matter would be greatly appreciated. Please advise us of the process necessary to obtain this approval. Our contact numbers are listed below.

Thank you.

Sincerely,

Mary Dacquino

978-335-2499

David Dacquino

339-223-2657

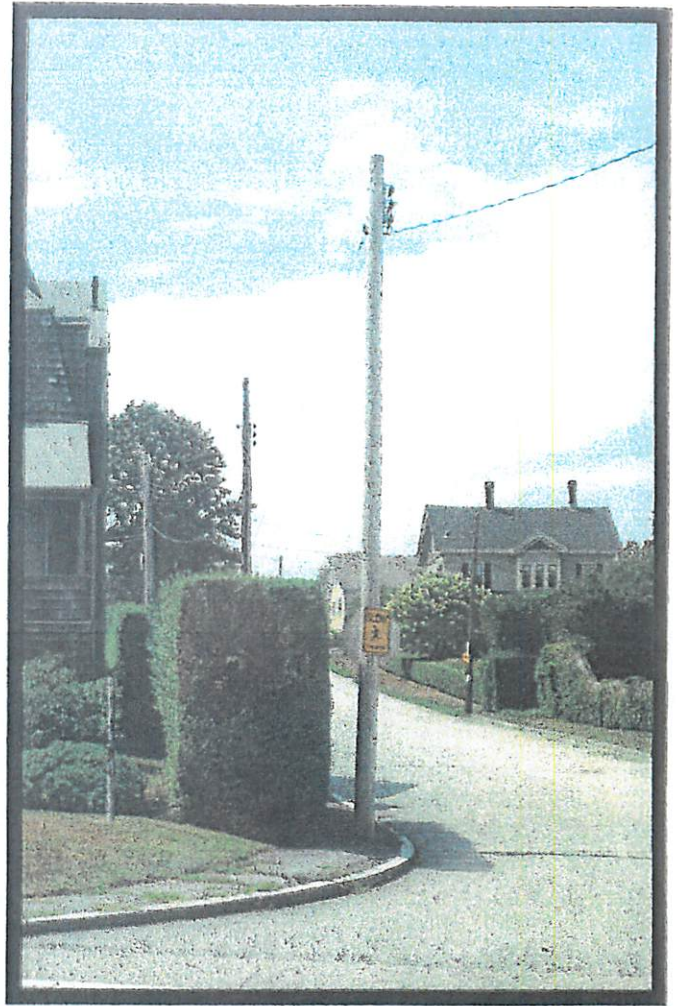
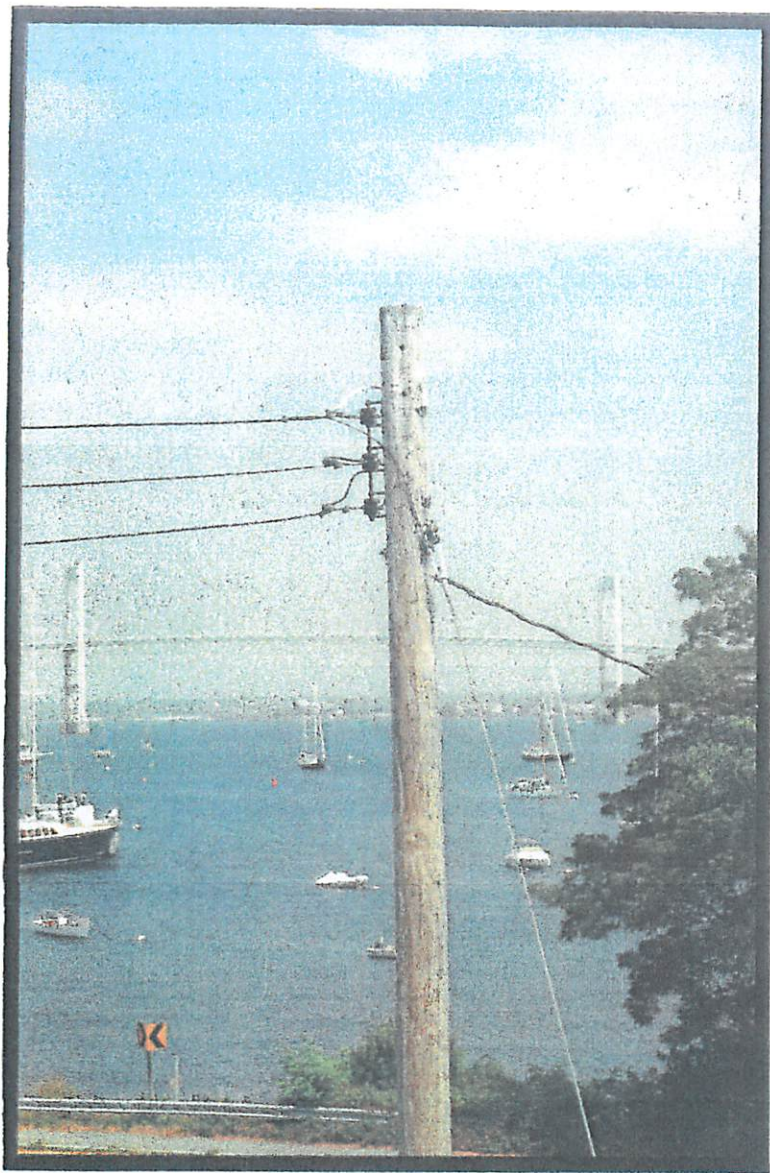

**View from water side of Walcott
looking west up Brook Street**

**View of power lines from
2 Walcott Avenue**

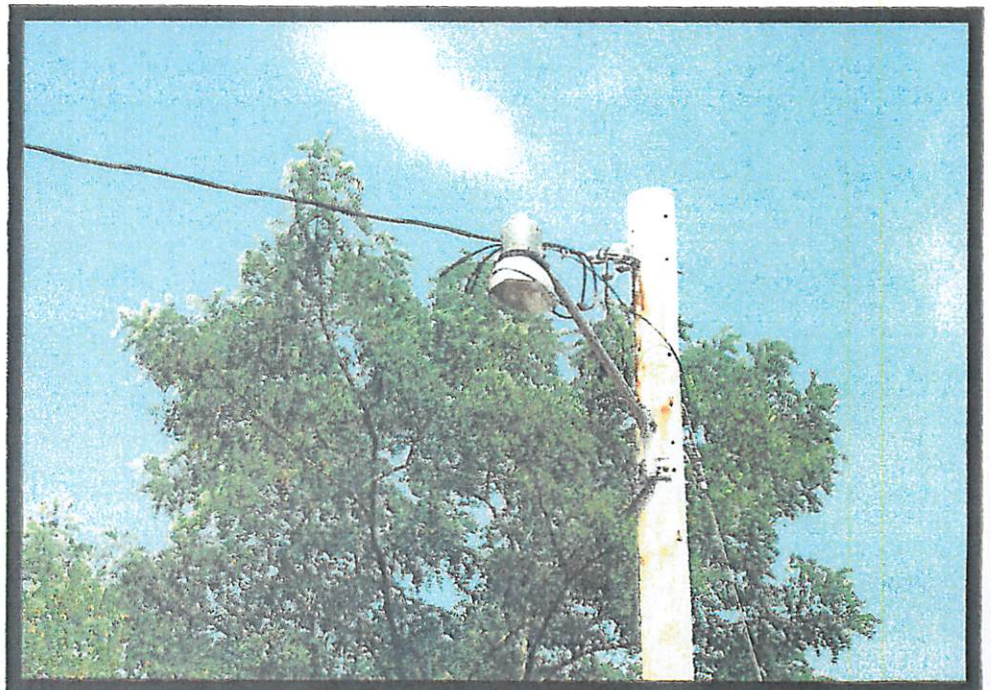

**View of existing light at
the corner of the Brook
Street and the
terminus of
Conanicus Ave and start
of Walcott Ave**

519 MAIN ST. - DUNSTABLE
CALMORE

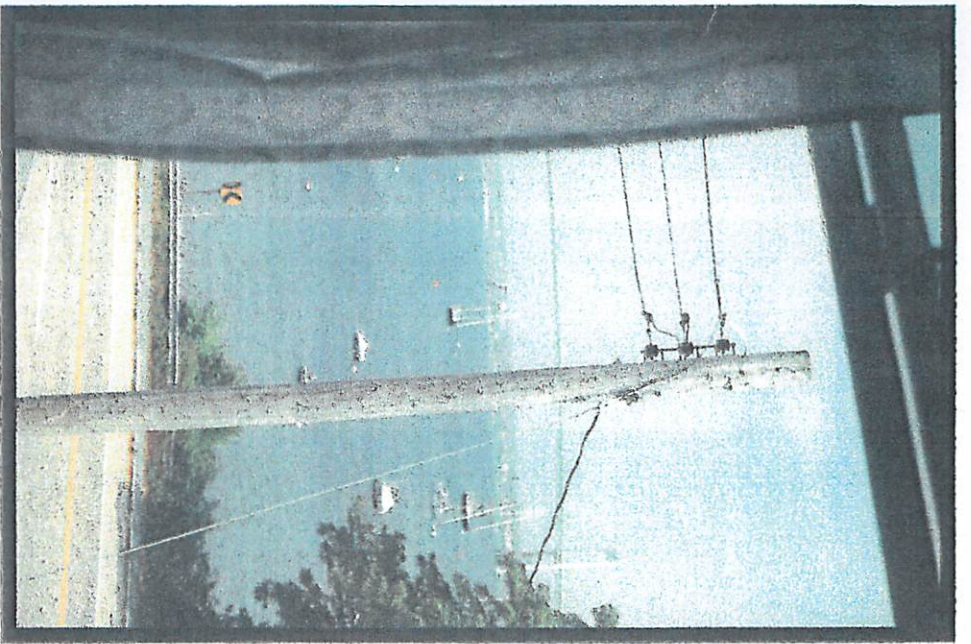

View out the east facing window of the second floor of 2 Walcott Avenue. This section of the house will be replaced with a north and east facing eight window turret. This pole is squarely in the middle of the view to the bridge.

View from the north side of Brook Street.

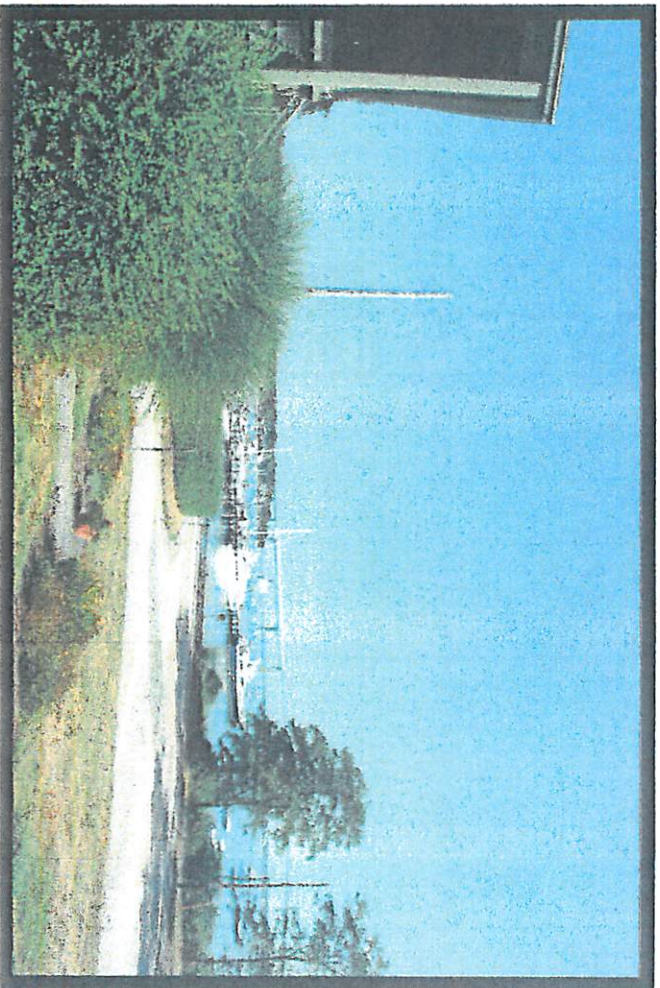

View from 4 Walcott Avenue.

4800 Lumen Solar Street Light

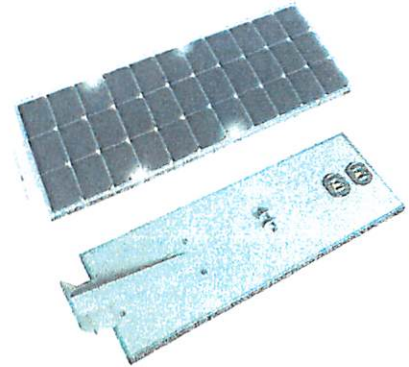

The 4800 Lumen Solar Street Light is a stand-alone unit that is powered by its own solar panel and battery, providing you up to 10-12 hours of light per night for 2 days on a single charge. Because they are pole-mounted and wireless, the installation is faster and simpler than grid connected counterparts.

Great for street and parking lot applications, where high visibility is a necessity.

Key Features:

- 75W Solar Panel integrated into the back of the light fixture
- Provides powerful lighting for 10-12 hrs per night
- 2 days of battery life on a single charge
- 3 Year Warranty

Technical Specifications:

- 75W Sunpower solar panel
- 12.8V 36Ah LiFePO4 Battery
- 4800 Lumen 40W LED Lamp
- Bridgelux LED Chip
- Color: 3000k-3500k/6000k- 6500k
- Working time (battery full): 2 days
- Charging Time: 8 Hours
- Certificate: CE, ROHS, IP65
- Installation Height: 13-26ft light pole
- Clearance of Installation: 2.75-3.5in
- Dimensions: 49.6in x 8.6in x 20in
- Net Weight: 57 lb

CAPSELLS.COM

206 W. McWilliams St. Suite 101
Fond du Lac, WI 54935
US

Quote #: TIU18353
Date Created: 8/29/16
Exp. Date: 9/28/16

Contact Information

Prepared By:	Matt M.	Contact Name:	Mary Dacquino
Phone #:	888-791-1463 x713	Phone #:	978-335-2499
E-Mail:	quotes@lightpolesplus.com	Email:	marydacquino@gmail.com
Fax:	414-255-2293	Fax:	

Address Information

Bill To Name:	Mary Dacquino (142603)	Ship To Name:	
Bill To:		Ship To:	

Standard Products

Qty	Product	Description	Sale Price	Ext. Price
1	RSSA-18-4040-11	18" Tall x 4.0" OD x 11ga Thick, Round Straight Steel, Anchor Base Light Pole, Anchor Bolt Kit & Full Base Cover, Wiring Hand Hole & Cover, Standard Fixture Mounting & Finish Color, USA Engineered & Manufactured	\$735.00	\$735.00
1	VS-VD	Steel Pole Option, Internal Vibration Damper, Factory Installed	\$64.62	\$64.62
1	VS-AB75	Pre-Shipped Anchor Bolt Kit, 0.75" x 17" x 3"	\$24.00	\$24.00
1	VS-PC	Top Cap Only, No Side Drilling	\$0.00	\$0.00
			Subtotal:	\$823.62
1. Pricing is based on a prepaid order release within 30 days and includes delivery within the contiguous USA unless otherwise noted. 2. Sales tax calculation (if applicable) will be finalized at order processing (OE). 3. Please consult your Technical Sales Manager for additional order terms and details.			Tax:	0.00%
			Tax Amount:	\$0.00
			Grand Total:	\$823.62

Optional Products

Important Notes:

Light Poles, Brackets & Arms

- Assumes White finish color
- [3] to [5] weeks estimated production lead time.
- Assumes new footing install
- Loading Assumption - light pole(s) rated for [6.0] EPA & [100] LBS at [80] MPH. No specific loading and/or wind zone criteria specified by customer.
- Loading Assumption - mounting quantity [1, light fixtures]; [0, brackets]; [0, cameras] per pole; no other pole attachments (including banners, flags, brackets, etc.).
- Customer to inspect and ensure that existing anchorage is structurally sufficient for pole and loading. Light poles are assumed to be mounting at grade.
- Customer has requested vibration dampeners.

Other Notes & Considerations

- WI & CA customers - resale certificate required to avoid sales tax.
- Non-Standard specifications may add to the production lead time.
- Customer responsible for unloading at time of delivery; line items may ship at different times during production cycle.

IMPORTANT: Do you require vibration dampeners? We recommend vibration dampeners be used when (1) light poles are being installed on a parking ramp, deck, bridge, pier, airport, train or subway hub/terminal or known problem area (2) a load of 0.75 EPA or smaller is going on the light poles and (3) light poles are being used as camera supports and/or will have non-standard appendages attached to them.

IMPORTANT: To ensure proper selection of the light pole, luminaire, accessories and/or foundation, we recommend the customer consult a qualified engineer to analyze the loading and design criteria for the specific application. Maximum loading capacity guidance is based on side-mounted light fixtures only.

IMPORTANT: LPP and its vendors are not responsible for the structural adequacy of new and/or existing light pole footing designs and anchor bolts. Estimated loading capacity values and wind zone ratings are based on standard commercial design and engineering criteria, and they do not account for additional loadings from objects such as (but not limited to) signs, banners, cameras, solar panels and flags. Our light pole warranty does not cover vibration induced fatigue failure.

IMPORTANT: LPP and its vendors consider these quoted products as produced and supplied according to the customer's dimensional, material and/or electrical specifications. Given the customer has not provided specific loading information, we have not engineered the products for the customer's specific application(s). The customer remains responsible for the product design, engineering and selection.

light poles PLUS.com  **LPP ENERGY**
USA Made LED Lighting

LPP: 888-791-1463
LPPe: 844-242-6967

quotes@lightpolesplus.com
quotes@lppenergy.com

2395 South Burrell Street | Suite 101
Milwaukee, WI 53207



100,000
HOURS
LED LIFE



FREE
Shipping





SPECIFICATIONS

Shaft – One-piece construction and fabricated from hot-rolled commercial quality carbon steel tubing with minimum yield strength of 42,000 psi.

Anchor Base – Fabricated from steel plate and conforms to ASTM A36.

Base Cover – Two-piece ABS plastic and finished with same color as pole.

Anchor bolts – Steel rod conforming to ASTM F1554 Grade 55 and provided with (2) hex nuts and (2) flat washers.

Handhole – Reinforced and supplied with cover, grounding provision and hardware.

Finish – Galvanized or powder-coat finish. Standard colors include dark bronze, medium bronze, black and white.

Mounting – Side drilled or tenon top.

Model Number	Mounting Height (ft)	Shaft			Base (in)		Loading Capacity		
		Base Diameter (in)	Top Diameter (in)	Wall Thickness (ga)	Bolt Circle	Bolt Diameter	Max EPA in Square Feet at (Allows for 3 Second Gust Factor):		
							80 MPH	90 MPH	100 MPH
RSSA-10-3030-11	10	3.0	3.0	11	7.0 - 9.0	0.75	9.3	7.1	5.6
RSSA-10-4040-11	10	4.0	4.0	11	7.0 - 9.0	0.75	17.7	13.9	11.3
RSSA-10-4545-11	10	4.5	4.5	11	7.0 - 9.0	0.75	22.7	18.0	14.6
RSSA-12-3030-11	12	3.0	3.0	11	7.0 - 9.0	0.75	7.1	5.4	4.1
RSSA-12-4040-11	12	4.0	4.0	11	7.0 - 9.0	0.75	13.9	10.9	8.8
RSSA-12-4545-11	12	4.5	4.5	11	7.0 - 9.0	0.75	18.3	14.5	11.7
RSSA-14-3030-11	14	3.0	3.0	11	7.0 - 9.0	0.75	5.6	4.1	3.1
RSSA-14-4040-11	14	4.0	4.0	11	7.0 - 9.0	0.75	11.3	8.7	7.0
RSSA-14-4545-11	14	4.5	4.5	11	7.0 - 9.0	0.75	15.0	11.8	9.5
RSSA-16-3030-11	16	3.0	3.0	11	7.0 - 9.0	0.75	4.3	3.0	2.1
RSSA-16-4040-11	16	4.0	4.0	11	7.0 - 9.0	0.75	8.9	6.8	5.5
RSSA-16-4545-11	16	4.5	4.5	11	7.0 - 9.0	0.75	12.1	9.4	7.6
RSSA-18-3030-11	18	3.0	3.0	11	7.0 - 9.0	0.75	3.1	2.1	1.3
RSSA-18-4040-11	18	4.0	4.0	11	7.0 - 9.0	0.75	7.0	5.3	4.2
RSSA-18-4545-11	18	4.5	4.5	11	7.0 - 9.0	0.75	9.7	7.6	6.0
RSSA-20-3030-11	20	3.0	3.0	11	7.0 - 9.0	0.75	2.2	1.3	-
RSSA-20-4040-11	20	4.0	4.0	11	7.0 - 9.0	0.75	5.6	4.1	3.1
RSSA-20-4545-11	20	4.5	4.5	11	7.0 - 9.0	0.75	7.9	6.1	4.8
RSSA-20-5050-11	20	5.0	5.0	11	7.0 - 9.0	0.75	10.8	8.4	6.7
RSSA-25-4040-11	25	4.0	4.0	11	7.0 - 9.0	0.75	2.6	1.8	1.2
RSSA-25-4545-11	25	4.5	4.5	11	7.0 - 9.0	0.75	4.4	3.3	2.5
RSSA-25-5050-11	25	5.0	5.0	11	7.0 - 9.0	0.75	6.7	5.1	3.9
RSSA-30-4545-11	30	4.5	4.5	11	7.0 - 9.0	0.75	2.1	1.4	0.9
RSSA-30-5050-11	30	5.0	5.0	11	7.0 - 9.0	0.75	3.9	2.8	2.0

RHODE ISLAND STATE PLANNING COUNCIL

NOTICE OF PUBLIC HEARING

In accordance with Rhode Island General Law, § 42-11-10 and Chapter 42-35, this is notice that the State Planning Council has under consideration the repeal of five State Guide Plan (SGP) Elements. The SGP is not a single document but a collection of plans referred to as Elements. As of September 2016, there are 25 Elements. There are five Elements that have not been updated in an extremely long time (see below). Due to their outdated nature, the content of these Elements has been found to have limited relevance to current conditions. The Division of Planning has contacted known stakeholders to determine if any of the five Elements might still have value or if there were any objections or concerns to the repeal of the Elements. No objections or concerns have been received to date. The Elements proposed for repeal are:

Element	Title	Date
110	Goals and Policies	Nov-74
112	Resources Management in the Reuse of Surplus Navy Lands	Apr-79
621	Policy Statement: Proposals for a New or Restructured Public Transit Facilities or Service	Jan-87
131	Cultural Heritage and Land Management Plan for the Blackstone River Valley National Heritage Corridor	Sep-90
912	Howard Center Master Plan, Phase 1	Oct-94

Notice is given that a public hearing will be held on the repeal of the five obsolete Elements at which time the opportunity shall be given to all persons interested to be heard upon the matter.

The date, time and location of the hearing is:

November 2, 2016 at 5:30 PM

Conference Room **A**, 2nd Floor
Department of Administration
One Capitol Hill
Providence, Rhode Island

The hearing will begin with a brief informational presentation about the proposed action followed by the opportunity for public comment. Written statements relative to any aspect of the proposed action, including alternative approaches, overlap, or potential economic impact, can be submitted in writing prior to, at the time of the hearing, emailed, or mailed by the close of business on Wednesday, November 2, 2016 to: Parag Agrawal, Associate Director, Division of Planning, One Capitol Hill, Providence, Rhode Island 02908.

The five Elements may be viewed at Statewide Planning's website at: <http://www.planning.ri.gov/> Copies of the five Elements are also available for review from 8:30 AM to 4:30 PM at the Department of Administration, Division of Planning, One Capitol Hill, 3rd Floor, Providence, Rhode Island (401-222-7901).

This meeting place is accessible to individuals with disabilities. Any individual requiring a reasonable accommodation in order to participate in this meeting should contact Thomas Mannock at 222-6395 (voice) or #711 (R.I. Relay) at least five (5) business days prior to the meeting.

Parag Agrawal, AICP
Secretary